

G529B(BC)-1\$;G529G(BC)-1\$

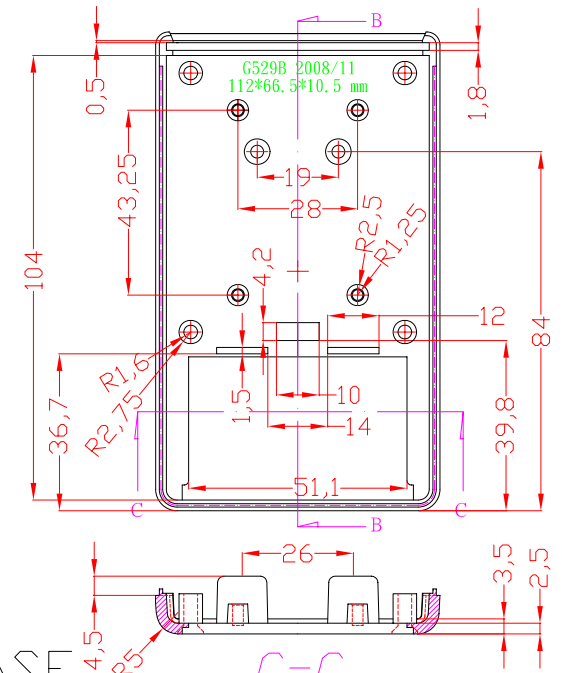

TOP

BASE

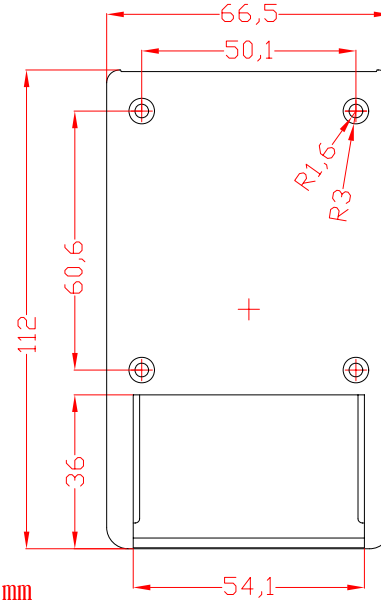
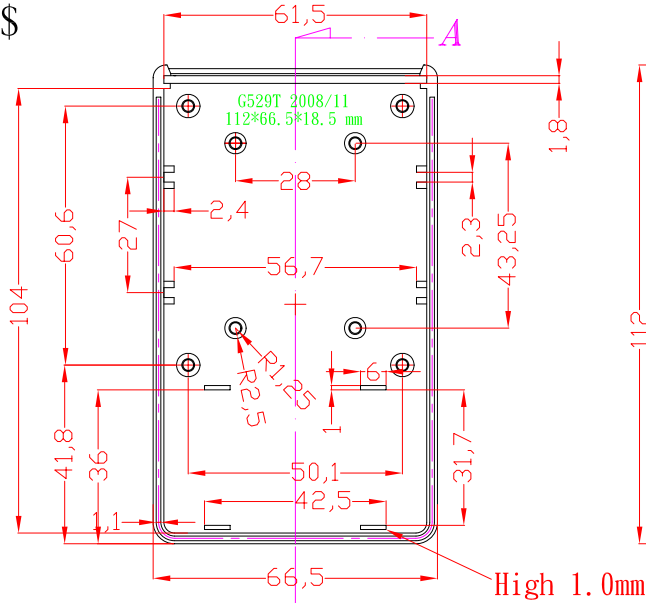
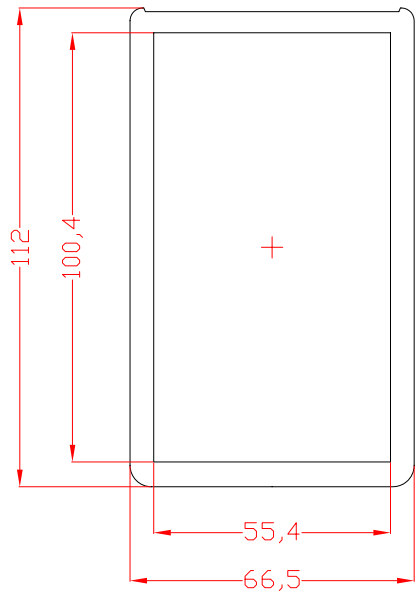
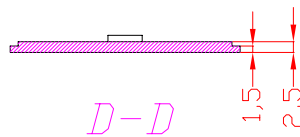
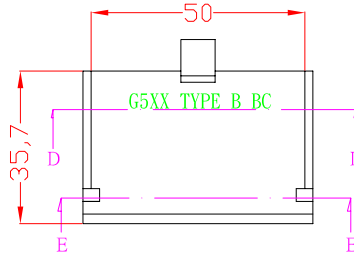
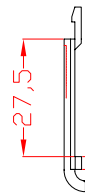
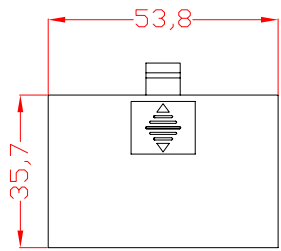

BATTERY-COVER

E-E

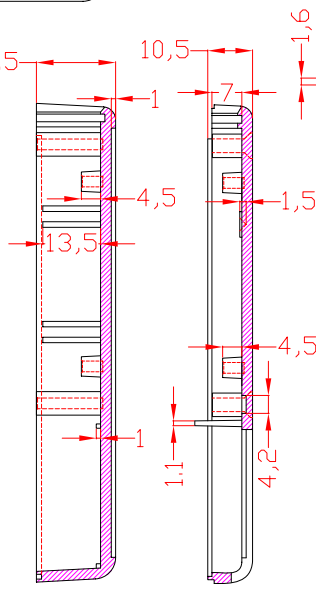

A-A B-B

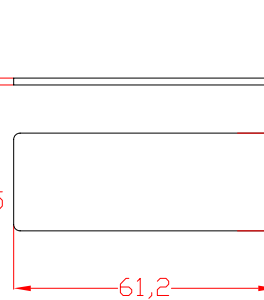

PANEL-"\$"

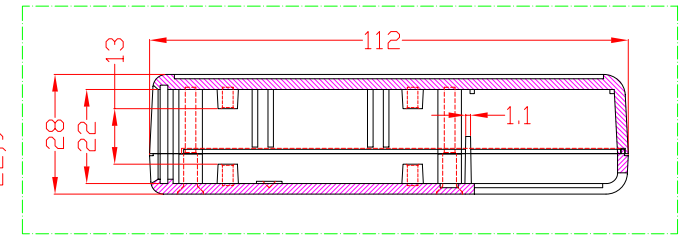

According to ISO 2768-m

Measuring DIM.=L	Tolerance	Measuring DIM.=L	Tolerance
0.5<L≤3.0 mm	±0.1 mm	30.0<L≤120.0 mm	±0.3 mm
3.0<L≤6.0 mm	±0.1 mm	120.0<L≤400.0 mm	±0.5 mm
6.0<L≤30.0 mm	±0.2 mm	400.0<L≤1000.0 mm	±0.8 mm

ITEM NO	DESCRIPTION
G529B(BC)-1\$	BLACK(G529T+G529B+PANEL-"\$"+B.C.)×1+M3×16 mm BLACK SCREWS ×4
G529G(BC)-1\$	GRAY(G529T+G529B+PANEL-"\$"+B.C.)×1+M3×16 mm BLACK SCREWS ×4