

G528B(BC)-1@;G528G(BC)-1@

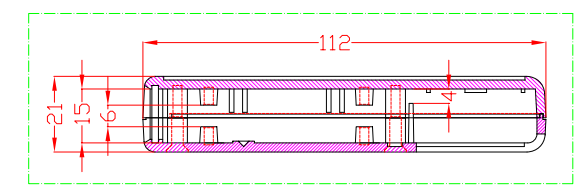
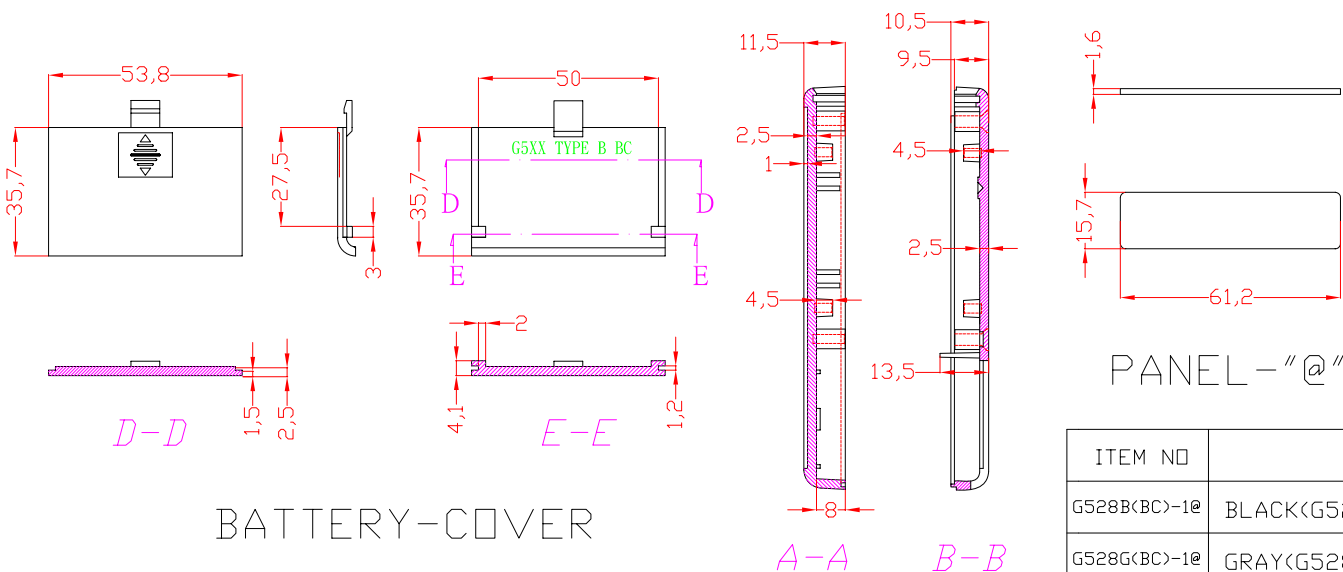
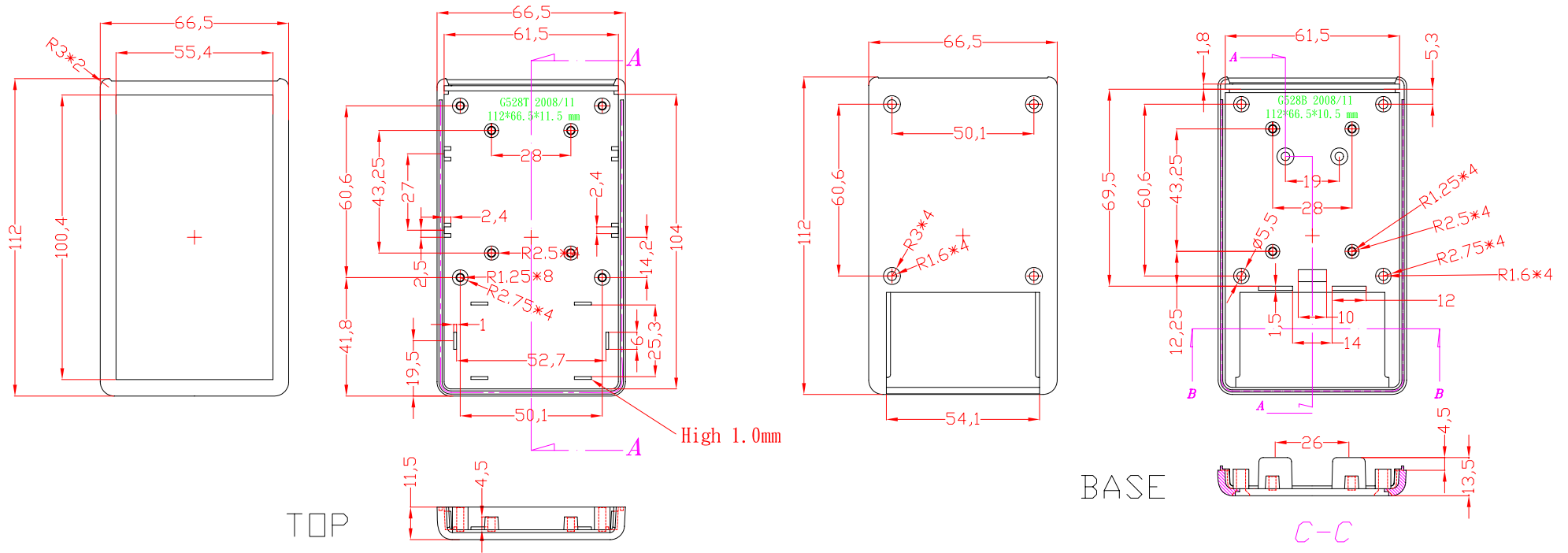

According to ISO 2768-m

Measuring DIM.=L	Tolerance	Measuring DIM.=L	Tolerance
0.5 < L ≤ 3.0 mm	±0.1 mm	30.0 < L ≤ 120.0 mm	±0.3 mm
3.0 < L ≤ 6.0 mm	±0.1 mm	120.0 < L ≤ 400.0 mm	±0.5 mm
6.0 < L ≤ 30.0 mm	±0.2 mm	400.0 < L ≤ 1000.0 mm	±0.8 mm

ITEM NO	DESCRIPTION
G528B(BC)-1@	BLACK(G528T+G528B+PANEL-"@"+B.C.)*1+M3*16 mm BLACK SCREWS *4
G528G(BC)-1@	GRAY(G528T+G528B+PANEL-"@"+B.C.)*1+M3*16 mm BLACK SCREWS *4

宣又實業有限公司 GAINTA INDUSTRIES LTD.	設計 DES'D BY	繪圖 DRA'D BY	核圖 CHK'D BY	比例 SCALE	日期 DATE	材質 MATE.	圖名 TITLE:	圖號 DWG NO.:	圖號 REVISID	說明 DESCRIPTION
		JACKY			2009/1/7	ABS	G528B(BC)-1@;G528G(BC)-1@		A	