

# G526B-2#;G526G-2#

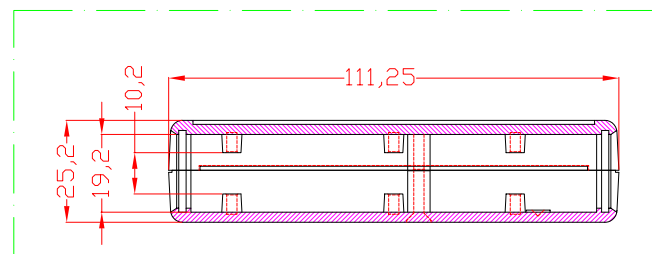
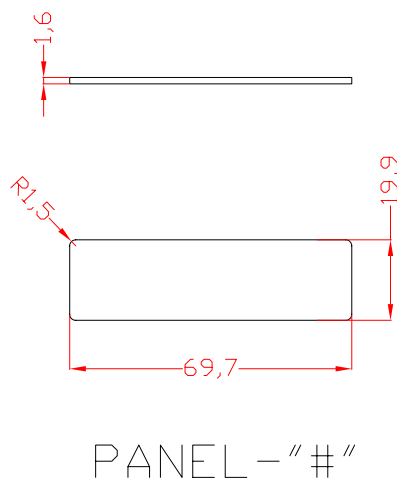
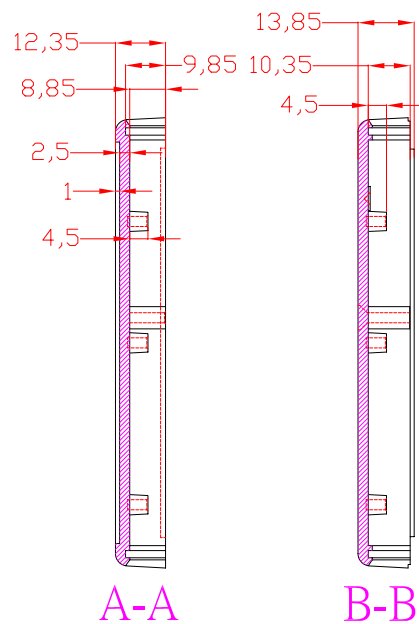
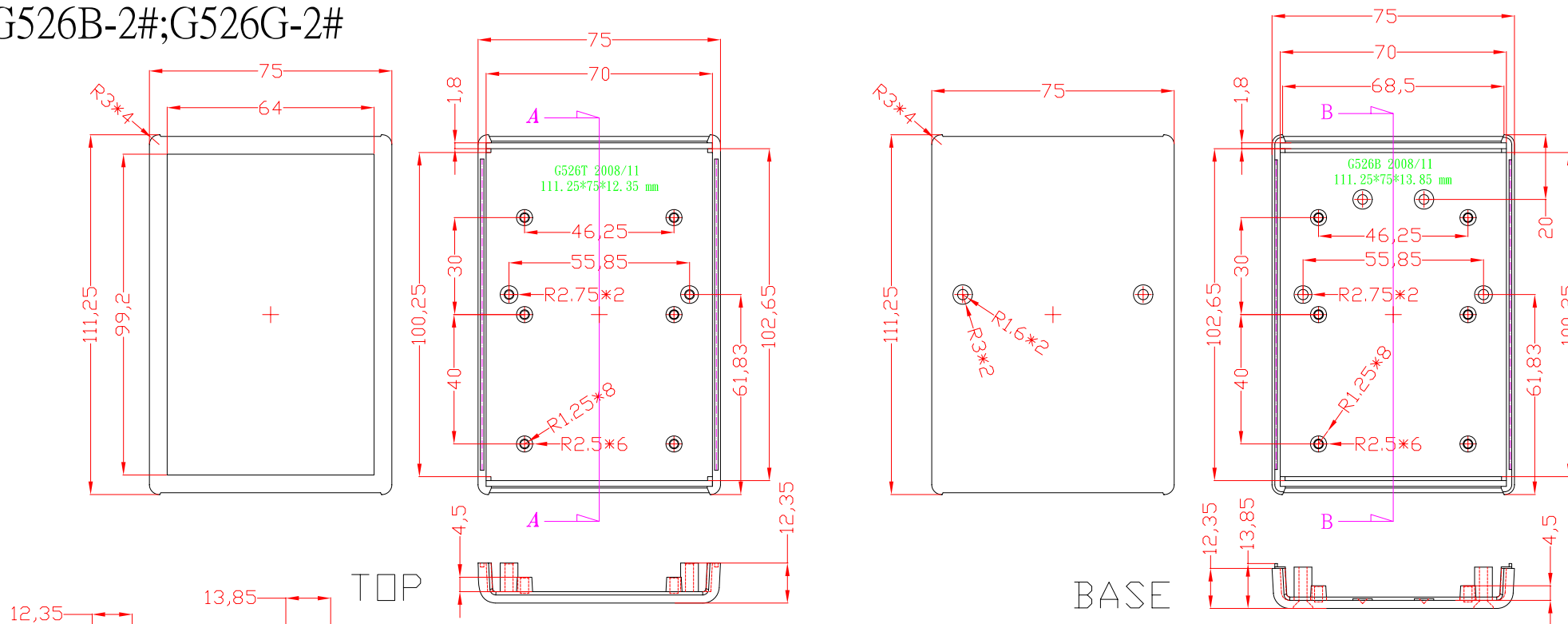

According to ISO 2768-m	
Measuring DIM=L	Tolerance
0.5<L≤3.0 mm	±0.1 mm
3.0<L≤6.0 mm	±0.1 mm
6.0<L≤30.0 mm	±0.2 mm
30.0<L≤120.0 mm	±0.3 mm
120.0<L≤400.0 mm	±0.5 mm
400.0<L≤1000.0 mm	±0.8 mm

ITEM NO	DESCRIPTION
G526B-2#	BLACK<G526T+G526B>*1+BLACK<PANEL-\"#\">*2+M3*21 mm BLACK SCREWS *2
G526G-2#	GRAY<G526T+G526B>*1+GRAY<PANEL-\"#\">*2+M3*21 mm BLACK SCREWS *2

宜又實業有限公司  
GAINTA INDUSTRIES LTD.

設計 DES'D BY  
繪圖 DRA'D BY  
核圖 CHK'D BY

JACKY

比例 SCALE

日期 DATE

2009/1/7

材質 MATE.  
ABS

圖名 TITLE:  
G526B-2#;G526G-2#

圖號 DWG NO.:

圖號 REVISID  
A  
說明 DESCRIPTION