

G512B-2\$;G512G-2\$

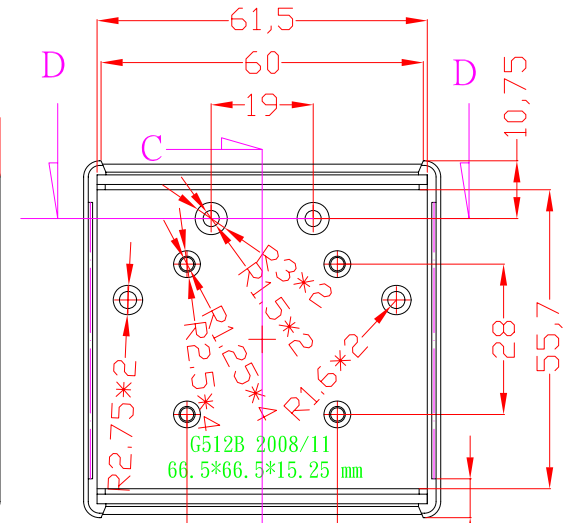
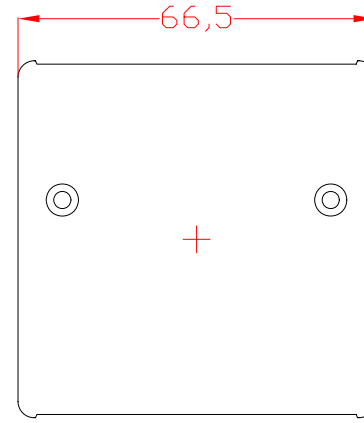
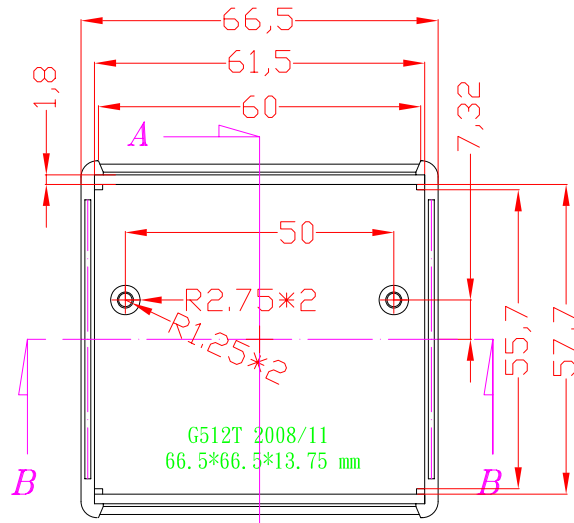
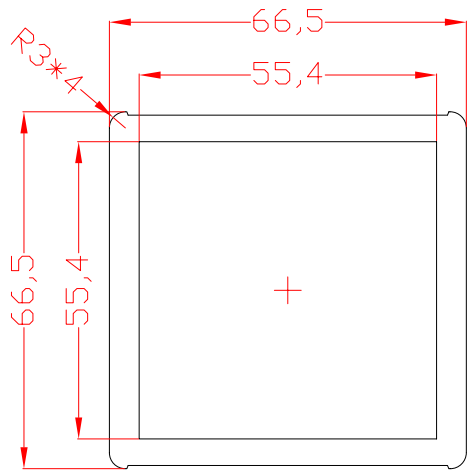

TOP

B-B

BASE

D-D

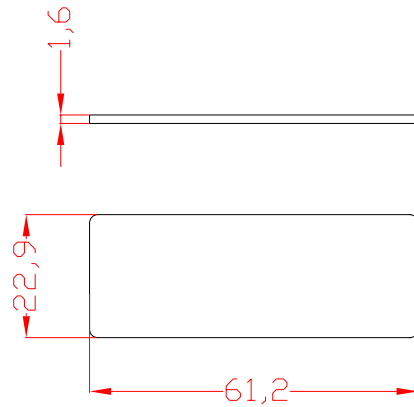
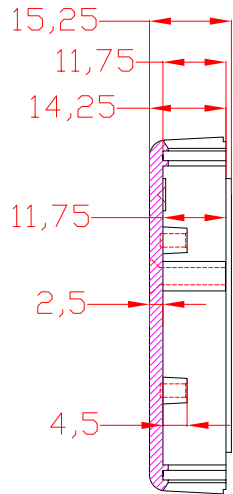
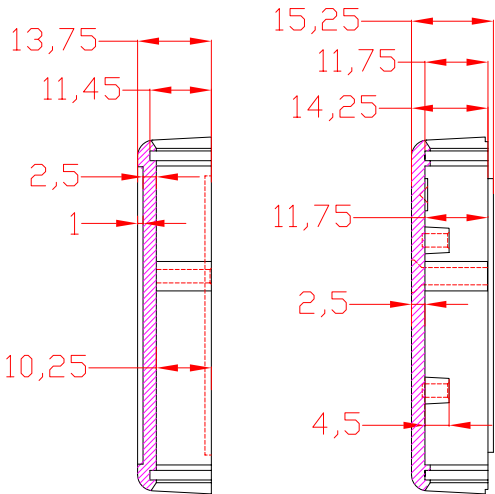

PANEL - "\$"

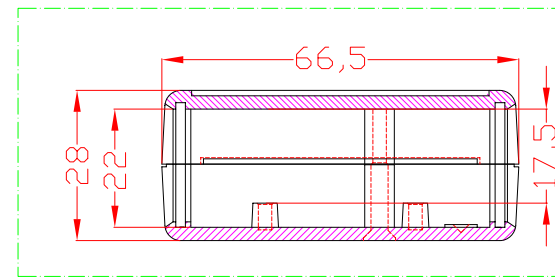

According to ISD 2768-m	
Measuring DIM.=L	Tolerance
0.5<L≤3.0 mm	±0.1 mm
3.0<L≤6.0 mm	±0.1 mm
6.0<L≤30.0 mm	±0.2 mm
30.0<L≤120.0 mm	±0.3 mm
120.0<L≤400.0 mm	±0.5 mm
400.0<L≤1000.0 mm	±0.8 mm

ITEM NO	DESCRIPTION
G512B-2\$	BLACK(G512T+G512B)*1+BLACK(PANEL-"\$")*2+M3*21 mm BLACK SCREWS *2
G512G-2\$	GRAY(G512T+G512B)*1+GRAY(PANEL-"\$")*2+M3*21 mm BLACK SCREWS *2

宣又實業有限公司
GAINTA INDUSTRIES LTD.

設計 DES'D BY
BY

繪圖 DRA'Y'D BY
BY

核圖 CHK'D BY
BY

比例 SCALE

日期 DATE

材質 MATE.

圖名 TITLE:
G512B-2\$;G512G-2\$

圖號 DWG NO.:

圖號 REVISID	說明 DESCRIPTION
A	