

Series No.	Pitch [mm]	Colour	Housing Type
JUMPER-B-Z	2.54	Black	Close
JUMPER-B	2.54	Black	Open
JUMPER-R-Z	2.54	Red	Close
JUMPER-R	2.54	Red	Open
JUMPER-G	2.54	Green	Open
JUMPER-BL	2.54	Blue	Open
JUMPER-H/B	2.54	Black	Open with handle
JUMPER-H/R	2.54	Red	Open with handle
JUMPER-2.0/B	2.0	Black	Open
JUMPER-2.0/R	2.0	Red	Open

### JUMPER-B-Z, -R-Z:

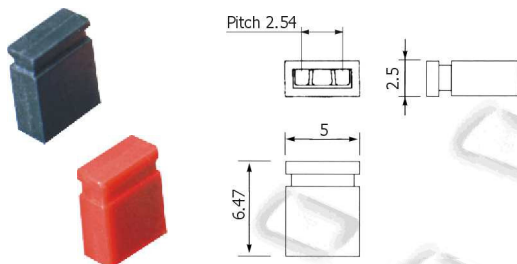

### JUMPER-B, -R, -G, -BL:

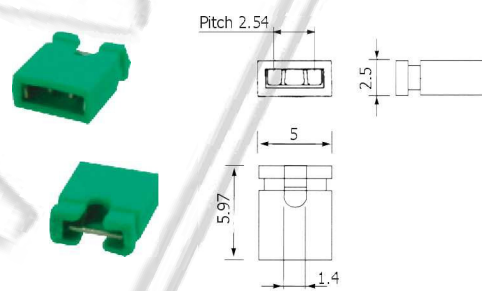

### JUMPER-2.0/B, -2.0/R:

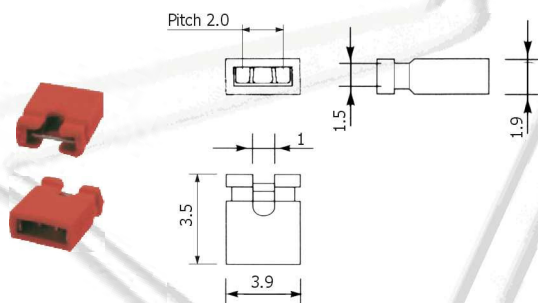

### JUMPER-H/B, -H/R:

