

H11L1M

H11L2M

H11L3M

PACKAGE

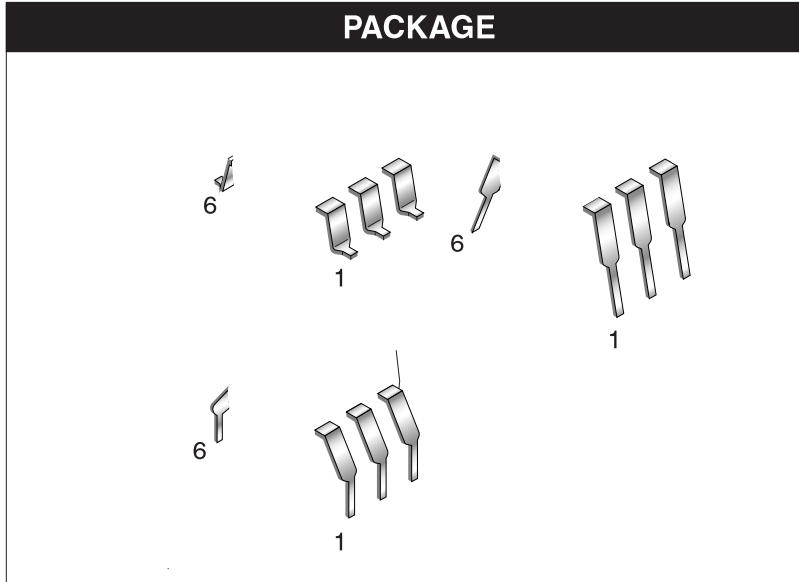

SCHEMATIC

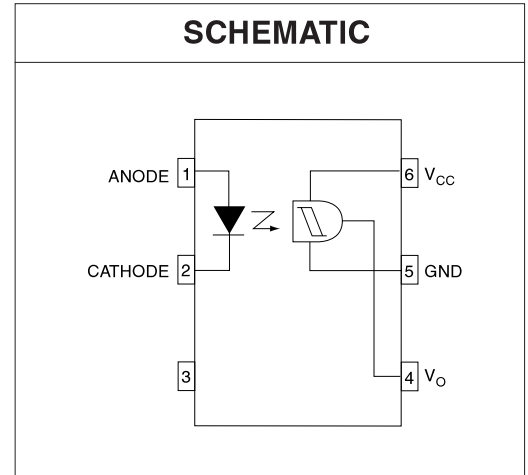

DESCRIPTION

The H11LXM series has a high speed integrated circuit detector optically coupled to a gallium-arsenide infrared emitting diode. The output incorporates a Schmitt trigger, which provides hysteresis for noise immunity and pulse shaping. The detector circuit is optimized for simplicity of operation and utilizes an open collector output for maximum application flexibility.

Truth Table

Input	Output
H	L
L	H

FEATURES

- High data rate, 1 MHz typical (NRZ)
- Free from latch up and oscillation throughout voltage and temperature ranges.
- Microprocessor compatible drive
- Logic compatible output sinks 16 mA at 0.4 V maximum
- Guaranteed on/off threshold hysteresis
- Wide supply voltage capability, compatible with all popular logic systems
- Underwriters Laboratory (UL) recognized—file #E90700, Volume 2
- VDE recognized – File#102497 – Add option V (e.g., H11L1VM)

APPLICATIONS

- Logic to logic isolator
- Programmable current level sensor
- Line receiver—eliminate noise and transient problems
- A.C. to TTL conversion—square wave shaping
- Digital programming of power supplies
- Interfaces computers with peripherals

H11L1M

H11L2M

H11L3M

ABSOLUTE MAXIMUM RATINGS

Parameters	Symbol	Device	Value	Units
TOTAL DEVICE				
Storage Temperature	T_{STG}	All	-55 to +150	°C
Operating Temperature	T_{OPR}	All	-40 to +85	°C
Lead Solder Temperature	T_{SOL}	All	260 for 10 sec	°C
Total Device Power Dissipation @ 25°C Derate Above 25°C	P_D	All	250 2.94	mW mW/°C
EMITTER				
Continuous Forward Current	I_F	All	60	mA
Reverse Voltage	V_R	All	6	V
Forward Current - Peak (1 μ s pulse, 300 pps)	$I_F(pk)$	All	3.0	A
LED Power Dissipation 25°C Ambient Derate Linearly From 25°C	P_D	All	120 1.41	mW mW/°C
DETECTOR				
Detector Power Dissipation @ 25°C Derate Linearly from 25°C	P_D	All	150 2.0	mW mW/°C
V_{45} Allowed Range	V_O	All	0 to 16	V
V_{65} Allowed Range	V_{CC}	All	3 to 16	V
I_4 Output Current	I_O	All	50	mA

ELECTRICAL CHARACTERISTICS ($T_A = 25^\circ\text{C}$ Unless otherwise specified.)

INDIVIDUAL COMPONENT CHARACTERISTICS

Parameters	Test Conditions	Symbol	Device	Min	Typ	Max	Units
EMITTER							
Input Forward Voltage	$I_F = 10\text{ mA}$	V_F	All		1.2	1.5	V
	$I_F = 0.3\text{ mA}$			0.75	1.0		
Reverse Current	$V_R = 3\text{ V}$	I_R	All			10	μA
Capacitance	$V = 0, f = 1.0\text{ MHz}$	C_J	All			100	pF
DETECTOR							
Operating Voltage Range		V_{CC}	All	3		15	V
Supply Current	$I_F = 0, V_{CC} = 5\text{ V}$	$I_{CC(off)}$	All		1.6	5.0	mA
Output Current, High	$I_F = 0, V_{CC} = V_O = 15\text{ V}$	I_{OH}	All			100	μA

H11L1M

H11L2M

H11L3M

ISOLATION CHARACTERISTICS

Parameters	Test Conditions	Symbol	Min	Typ	Max	Units
Input-Output Isolation Voltage	t = 1 sec.	V_{ISO}	7500			V_{PEAK}
Isolation Capacitance	$V_{I-O} = 0V, f = 1 \text{ MHz}$	C_{ISO}		0.4	0.6	pF
Isolation Resistance	$V_{I-O} = \pm 500 \text{ VDC}$	R_{ISO}	10^{11}			Ω

TRANSFER CHARACTERISTICS

DC Characteristics	Test Conditions	Symbol	Device	Min	Typ	Max	Units
Supply Current	$I_F = 10\text{mA}, V_{CC} = 5V$	$I_{CC(on)}$	All		1.6	5.0	mA
Output Voltage, low	$R_L = 270\Omega, V_{CC} = 5V, I_F = I_{F(on)} \text{ max.}$	V_{OL}	All		0.2	0.4	V
Turn-On Threshold Current	$R_L = 270\Omega, V_{CC} = 5V$	$I_{F(on)}^*$	H11L1M			1.6	mA
			H11L2M			10.0	
			H11L3M			5.0	
Turn-Off Threshold Current	$R_L = 270\Omega, V_{CC} = 5V$	$I_{F(off)}$	All	0.3	1.0		mA
Hysteresis Ratio	$R_L = 270\Omega, V_{CC} = 5V$	$I_{F(off)}/I_{F(on)}$	All	0.50	0.75	0.90	
AC Characteristics	Test Conditions	Symbol	Device	Min	Typ	Max	Units
SWITCHING SPEED							
Turn-On time	$R_L = 270\Omega, V_{CC} = 5V, I_F = I_{F(on)}, T_A = 25^\circ\text{C}$	t_{on}	All		1.0		μs
					0.65		
						4	
Fall Time	$R_L = 270\Omega, V_{CC} = 5V, I_F = I_{F(on)}, T_A = 25^\circ\text{C}$	t_f	All		0.1		μs
					.05		
					0.1		
Turn-Off Time	$R_L = 270\Omega, V_{CC} = 5V, I_F = I_{F(on)}, T_A = 25^\circ\text{C}$	t_{off}	All		2.0		μs
					1.2		
						4	
Rise time	$R_L = 270\Omega, V_{CC} = 5V, I_F = I_{F(on)}, T_A = 25^\circ\text{C}$	t_r	All		0.1		μs
					0.07		
					0.1		
Data Rate			All		1.0		MHz

NOTE:

*Maximum $I_{F(ON)}$ is the maximum current required to trigger the output. For example, a 1.6mA maximum trigger current would require the LED to be driven at a current greater than 1.6mA to guarantee the device will turn on. A 10% guard band is recommended to account for degradation of the LED over its lifetime. The maximum allowable LED drive current is 60mA.

H11L1M

H11L2M

H11L3M

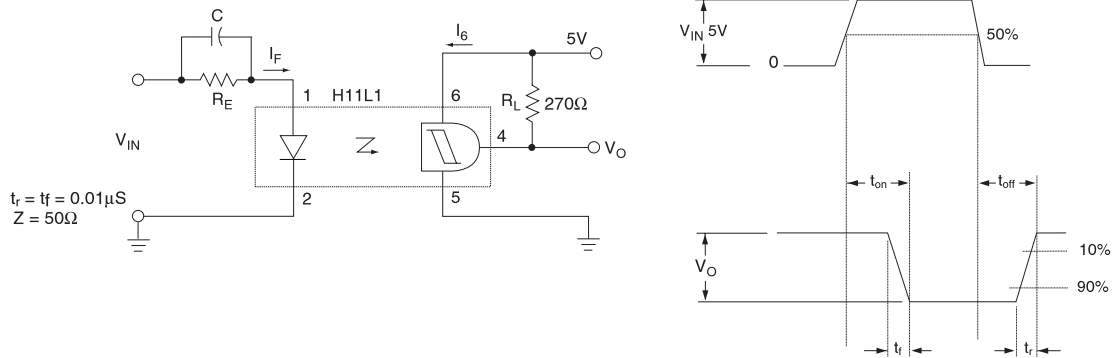

Figure 1. Switching Test Circuit and Waveforms

TYPICAL PERFORMANCE CURVES

Figure 2. Transfer Characteristics

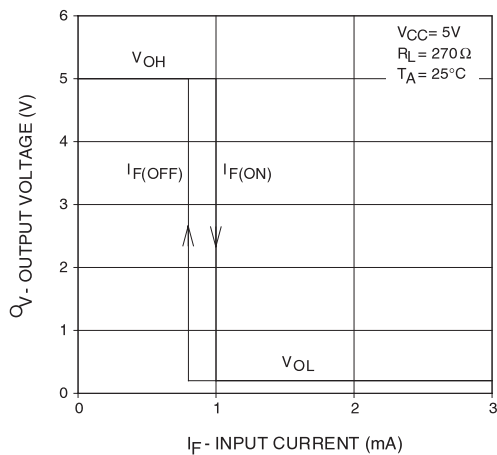

Figure 3. Threshold Current vs. Supply Voltage

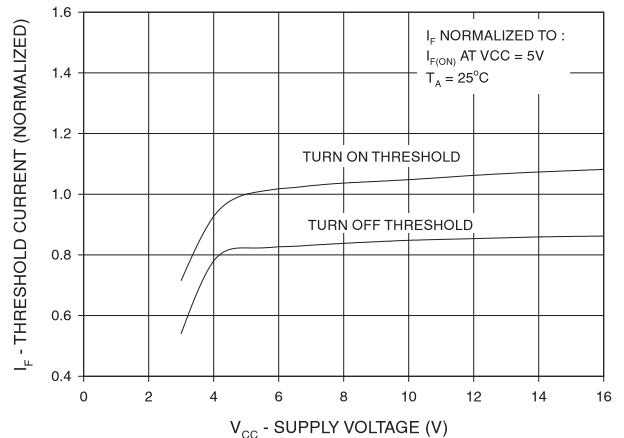

Figure 4. Threshold Current vs. Supply Temperature

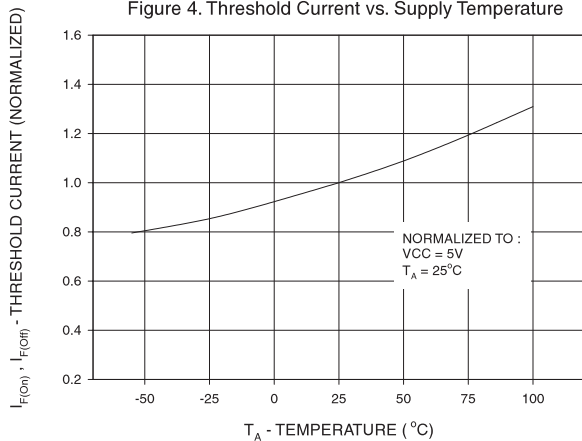
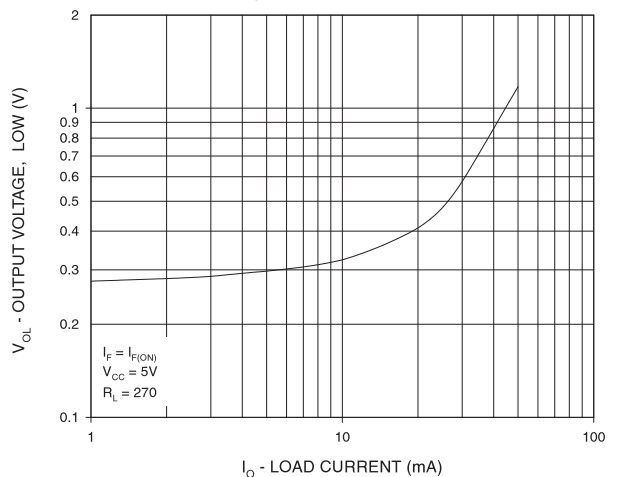

Figure 5. Output Voltage, Low vs. Load Current



H11L1M

H11L2M

H11L3M

TYPICAL PERFORMANCE CURVES

Figure 6. Supply Current vs. Supply Voltage

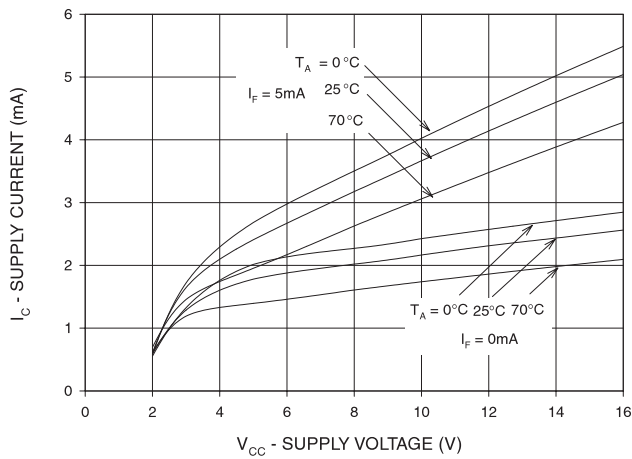
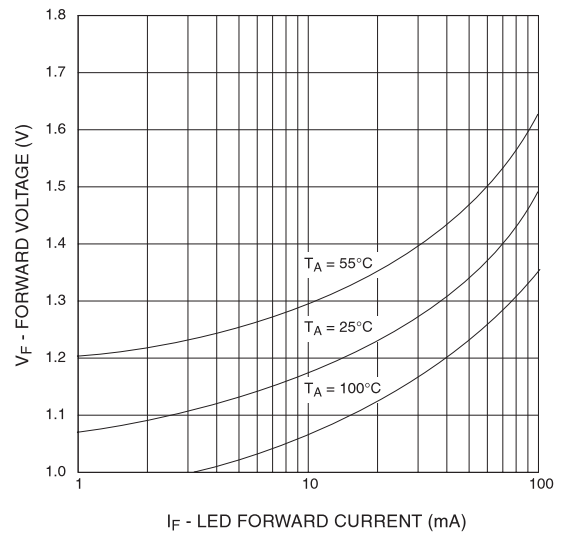

Figure 7. LED Forward Voltage vs. Forward Current



H11L1M

H11L2M

H11L3M

Package Dimensions (Through Hole)

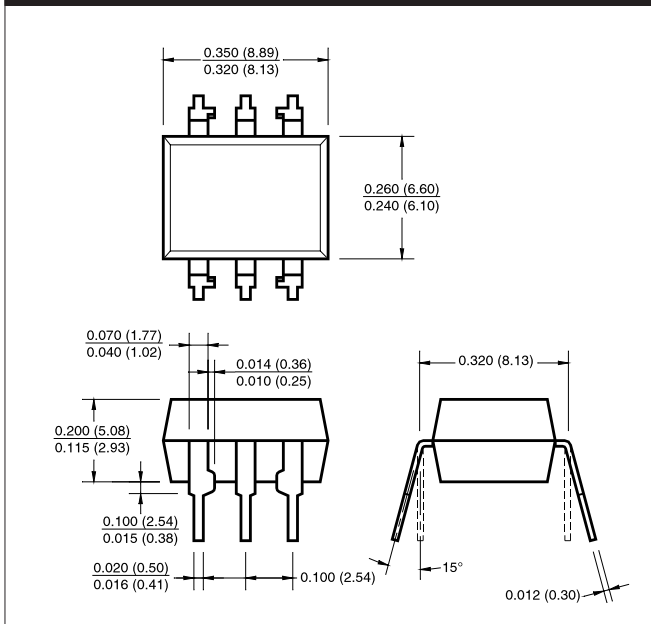

Package Dimensions (Surface Mount)

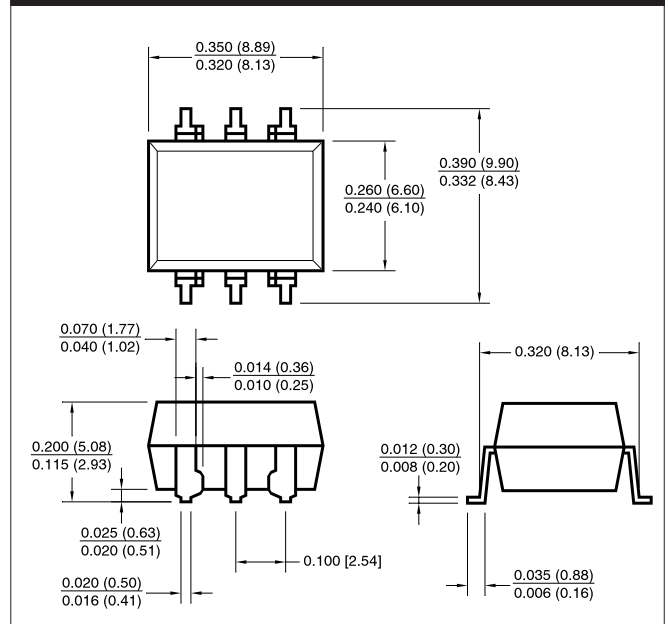

Package Dimensions (0.4" Lead Spacing)

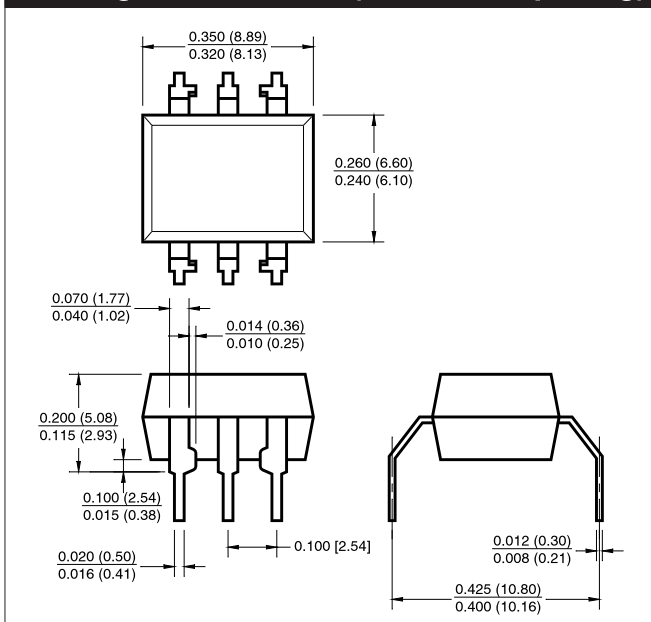

Recommended Pad Layout for Surface Mount Leadform

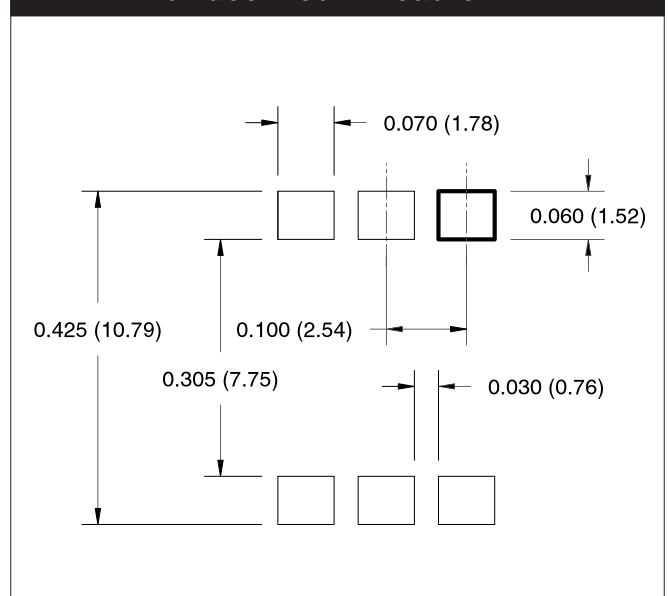

NOTE

All dimensions are in inches (millimeters)

H11L1M

H11L2M

H11L3M

ORDERING INFORMATION

Option/Order Entry Identifier	Description
S	Surface Mount Lead Bend
SR2	Surface Mount; Tape and reel
T	0.4" Lead Spacing
V	VDE 0884
TV	VDE 0884, 0.4" Lead Spacing
SV	VDE 0884, Surface Mount
SR2V	VDE 0884, Surface Mount, Tape & Reel

MARKING INFORMATION

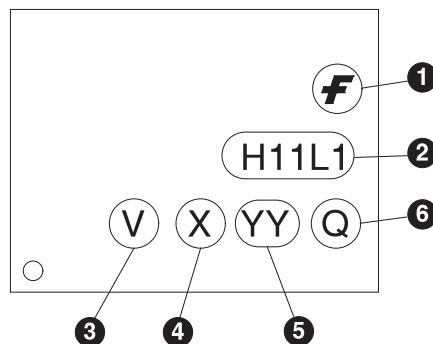

Definitions	
1	Fairchild logo
2	Device number
3	VDE mark (Note: Only appears on parts ordered with VDE option – See order entry table)
4	One digit year code, e.g., '3'
5	Two digit work week ranging from '01' to '53'
6	Assembly package code

*Note – 'V' option parts marked with date code '325' or earlier are marked in portrait format.

H11L1M

H11L2M

H11L3M

Carrier Tape Specifications

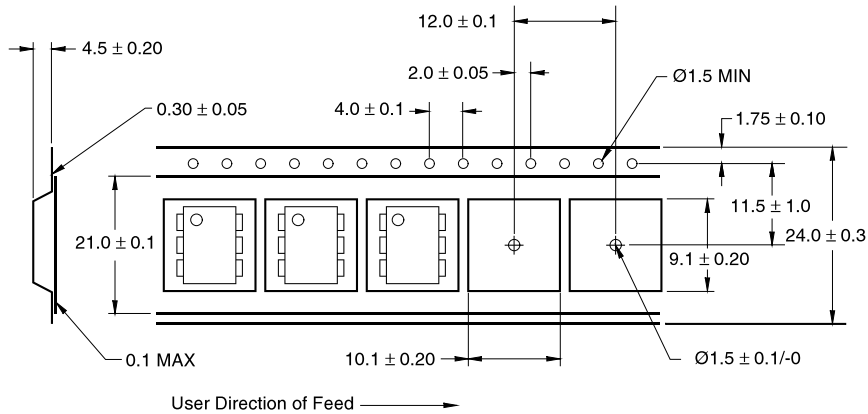

NOTE

All dimensions are in inches (millimeters)

Reflow Profile

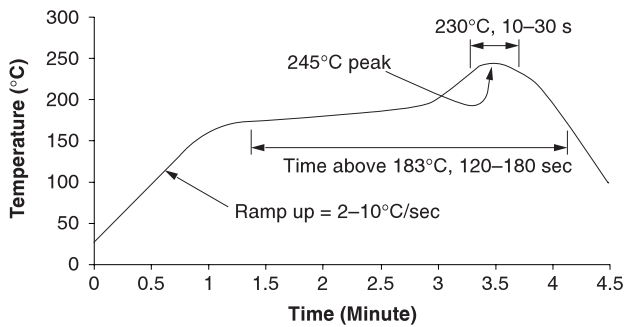

- Peak reflow temperature: 245°C (package surface temperature)
- Time of temperature higher than 183°C for 120-180 seconds
- One time soldering reflow is recommended

H11L1M

H11L2M

H11L3M

DISCLAIMER

FAIRCHILD SEMICONDUCTOR RESERVES THE RIGHT TO MAKE CHANGES WITHOUT FURTHER NOTICE TO ANY PRODUCTS HEREIN TO IMPROVE RELIABILITY, FUNCTION OR DESIGN. FAIRCHILD DOES NOT ASSUME ANY LIABILITY ARISING OUT OF THE APPLICATION OR USE OF ANY PRODUCT OR CIRCUIT DESCRIBED HEREIN; NEITHER DOES IT CONVEY ANY LICENSE UNDER ITS PATENT RIGHTS, NOR THE RIGHTS OF OTHERS.

LIFE SUPPORT POLICY

FAIRCHILD'S PRODUCTS ARE NOT AUTHORIZED FOR USE AS CRITICAL COMPONENTS IN LIFE SUPPORT DEVICES OR SYSTEMS WITHOUT THE EXPRESS WRITTEN APPROVAL OF THE PRESIDENT OF FAIRCHILD SEMICONDUCTOR CORPORATION. As used herein:

1. Life support devices or systems are devices or systems which, (a) are intended for surgical implant into the body, or (b) support or sustain life, and (c) whose failure to perform when properly used in accordance with instructions for use provided in the labeling, can be reasonably expected to result in a significant injury of the user.
2. A critical component in any component of a life support device or system whose failure to perform can be reasonably expected to cause the failure of the life support device or system, or to affect its safety or effectiveness.