

HFKC/HFKC-T

AUTOMOTIVE RELAY



Single



Twin

Typical Applications

Central door lock, Wiper control, Indicator control, Power door & windows, Anti-theft lock, Rear window and seat heating control, Lighting/flashlight/indicator lamp control

Features

- Subminiature automotive relay
- Maximum continuous current 30A
- Twin separate systems (Twin version)
- The reflow soldering Version (open vent hole) available (HFKC-T)
- RoHS & ELV compliant

CHARACTERISTICS

Contact arrangement	Single: 1A, 1C Twin: 2A, 2C	Release time	Typ.: 2ms Max.: 10ms ⁴⁾
Voltage drop (initial) ¹⁾	Typ.: 100mV (at 10A) Max.: 250mV (at 10A)	Ambient temperature	-40°C to 105°C
Max. continuous current	NO/NC: 30A/25A (at 23°C) 20A/15A (at 85°C)	Storage temperature	-40°C to 155°C
Max. switching current ²⁾ (NO contact)	30A	Vibration resistance	10Hz to 500Hz 58.8m/s ²
Max. switching voltage	16V	Shock resistance	294m/s ²
Electrical endurance	See "CONTACT DATA" table	Termination	PCB ⁵⁾
Mechanical endurance	1x10 ⁷ OPS (300OPS/min)	Construction	Wash tight, Flux proofed
Initial insulation resistance	100MΩ (at 500VDC)	Unit weight	Single version: Approx. 4g Twin version: Approx. 8g
Dielectric strength	500VAC (1min, leakage current less than 1mA)		
Operate time	Typ.: 4ms Max.: 10ms (at nomi. vol.)		

- 1) Equivalent to the max. initial contact resistance is 100mΩ (at 1A 6VDC).
- 2) The value apply to a resistive load.
- 3) The value is measured when voltage drops suddenly from nominal voltage to 0 VDC and coil is not paralleled with suppression circuit.
- 4) Since it is an environmental friendly product, please select lead-free solder when welding. The recommended soldering temperature and time is 240°C to 260°C, 2s to 5s.

CONTACT DATA⁵⁾

at 23°C

Load voltage	Load type		Load current A		On/Off ratio		Electrical endurance OPS	Contact material	Load wiring diagram ⁴⁾
			1C, 2C		On s	Off s			
			NO	NC					
13.5VDC	Resistive	Make	20	---	1	3	3×10 ⁵	AgSnO ₂	See diagram 1
		Break	20	---					
	Wiper L=1.0mH	Make	25 ¹⁾	---	0.2	2	3×10 ⁵	AgSnO ₂	See diagram 2
		Break	5	---					
	Motor locked L=0.77mH	Make	20	---	0.2	2	1×10 ⁵	AgSnO ₂	See diagram 3
		Break	20	---					



HONGFA RELAY

ISO9001, ISO/TS16949, ISO14001, OHSAS18001, IECQ QC 080000 CERTIFIED

2008 Rev. 1.00

Load voltage	Load type		Load current A	On/Off ratio		Electrical endurance OPS	Contact material	Load wiring diagram ⁴⁾
			1A, 2A	On s	Off s			
13.5VDC	Resistive	Make	20	1	3	3×10^5	AgSnO ₂	See diagram 4
		Break	20					
	Flasher ³⁾	Make	3×21W	0.365	0.365	2×10^6	Special AgSnO ₂	See diagram 5
		Break						
	Lamp	Make	40 ²⁾	2	2	1×10^5	AgSnO ₂	See diagram 6
		Break	10					

1) Corresponds to the peak inrush current on initial actuation (motor).

2) Corresponds to the peak inrush current on initial actuation (cold filament).

3) When it is utilized in flasher, a special AgSnO₂ contact material should be used and the customer special code should be (170) as a suffix. Please connect by the polarity according to the diagrams below.

4) The load wiring diagrams are listed below. When special AgSnO₂ contacts are applied, please heed the anode and cathode's request when wired.

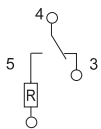

diagram 1

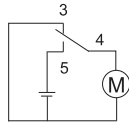

diagram 2

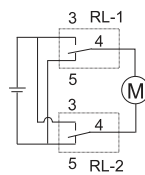

diagram 3

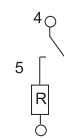

diagram 4

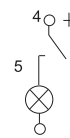

diagram 5

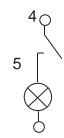

diagram 6

5) When the load requirement is different from content of the table above, please contact Hongfa for relay application support.

COIL DATA

at 23°C

Nominal voltage ²⁾ VDC	Pick-up voltage VDC	Drop-out voltage VDC	Coil resistance $x(1 \pm 10\%) \Omega$	Power consumption W	Max. allowable overdrive voltage ¹⁾ VDC	
					23°C	85°C
6	3.5	0.8	63	0.55	13.2	7.8
10	5.7	1.25	181	0.55	22	13
12	6.9	1.5	254	0.55	26	16
12	6.9	1.5	181	0.80	22	13

1) Max. allowable overdrive voltage is stated with no load applied.

2) When requiring some other nominal voltage, special order allowed.

ORDERING INFORMATION

		HFKC /		012	Z	S	P	T	(XXX)
Type	HFKC: Standard HFKC-T: Reflow soldering version								
Coil voltage	006: 6VDC 010: 10VDC 012: 12VDC								
Contact arrangement	Z: 1 Form C 2Z: 2 Form C			H: 1 Form A 2H: 2 Form A					
Construction	S: Wash tight (HFKC)				Nil: Flux proofed (HFKC-T)				
Coil power	P: 0.8W				Nil: 0.55W				
Contact material	T: AgSnO ₂								
Customer special code	e.g. (170) stands for flasher load								

OUTLINE DIMENSIONS, WIRING DIAGRAM AND PC BOARD LAYOUT

Unit: mm

Outline Dimensions

Single version

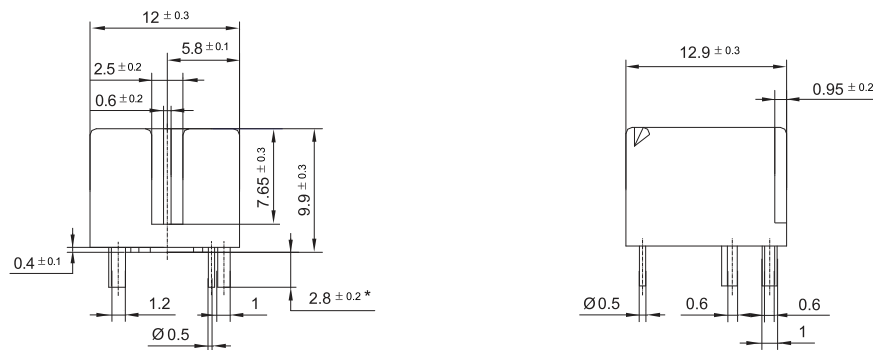

Twin version

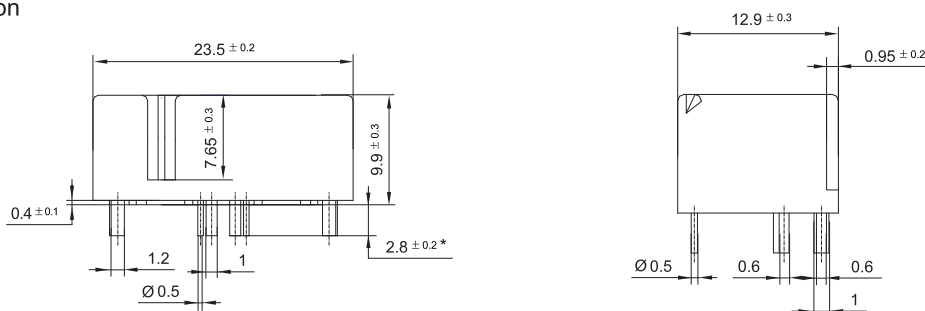

Notes: 1) * The additional tin top is max. 1mm;
 2) The terminal vertical deviation tolerance is 0.2mm.

OUTLINE DIMENSIONS, WIRING DIAGRAM AND PC BOARD LAYOUT

Unit: mm

PCB Layout (Bottom view)

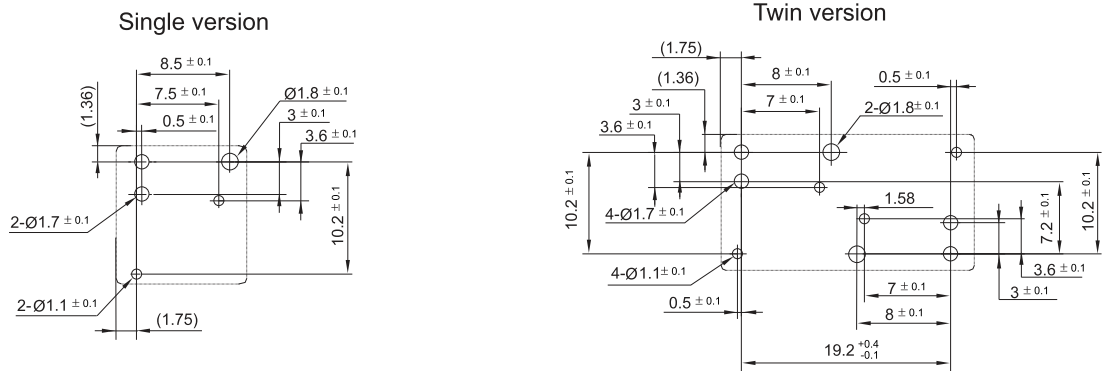

Wiring Diagram (Bottom view)

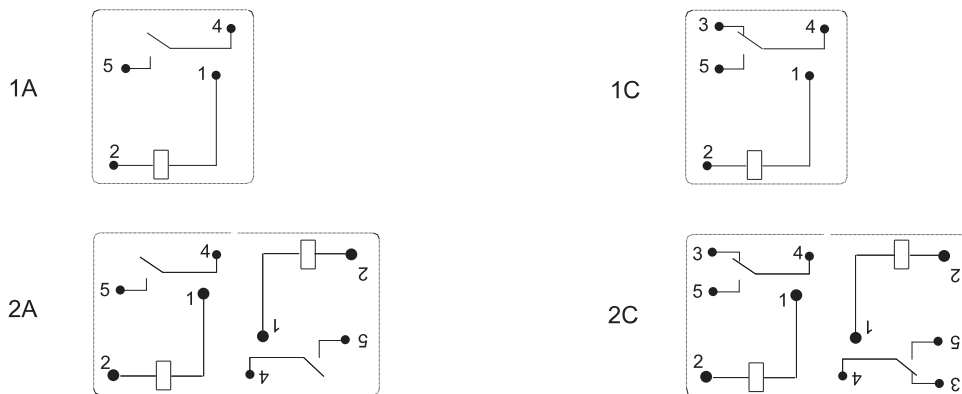

CHARACTERISTIC CURVES

1. Coil operating voltage range

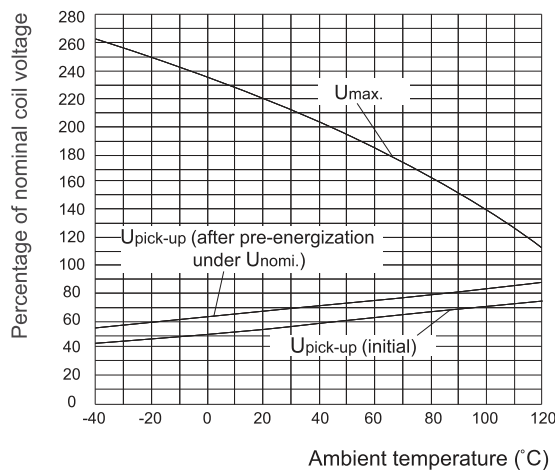

- 1) The operating voltage is connected with coil pre-energized time and voltage. After pre-energized, the operating voltage will increase.
- 2) The maximum allowable coil temperature is 180°C. For the coil temperature rise which is measured by resistance is average value, we recommend the coil temperature should be below 170°C under the different application ambient, different coil voltage and different load etc.
- 3) If the actual operating coil voltage is out of the specified range, please contact Hongfa for further details.

Disclaimer

This datasheet is for the customers' reference. All the specifications are subject to change without notice.

We could not evaluate all the performance and all the parameters for every possible application. Thus the user should be in a right position to choose the suitable product for their own application. If there is any query, please contact Hongfa for the technical service. However, it is the user's responsibility to determine which product should be used only.