

HF46F-G

SUBMINIATURE INTERMEDIATE POWER RELAY



File No.: E134517



File No.: 40025215



File No.: CQC08001024932



Features

- 10A switching capability
- 10kV impulse withstand voltage (between coil and contacts)
- Type 2 meets VDE 0700, 0631 reinforce insulation
- Highly efficient magnetic circuit for high sensitivity: 200mW
- Extremely small footprint utilizing PCB area
- Environmental friendly product (RoHS compliant)
- Outline Dimensions: (20.5 x 7.2 x 15.3) mm

CONTACT DATA

Contact arrangement	1A	
Contact resistance	100mΩ (at 1A 24VDC)	
Contact material	AgNi, AgSnO ₂	
Contact rating (Res. load)	7A 250VAC / 28VDC	
Max. switching voltage	277VAC / 30VDC	
Max. switching current	10A	
Max. switching power	2770VA / 300W	
Mechanical endurance	5 x 10 ⁶ OPS	
Electrical endurance	AgNi	1 x 10 ⁵ OPS (at 7A 250VAC, 10OPS/min)
		1 x 10 ⁴ OPS (at 10A 250VAC, 6OPS/min)
	AgSnO ₂	3 x 10 ⁴ OPS (at 7A 250VAC, 10OPS/min)
		1 x 10 ⁴ OPS (at 10A 250VAC, 6OPS/min)

CHARACTERISTICS

Insulation resistance	1000MΩ (at 500VDC)	
Dielectric strength	Between coil & contacts	4000VAC 1min
	Between open contacts	1000VAC 1min
Surge voltage (between coil & contacts)	10kV (1.2X50μs)	
Operate time (at nomi. volt.)	10ms max.	
Release time (at nomi. volt.)	10ms max.	
Shock resistance	Functional	98m/s ²
	Destructive	980m/s ²
Vibration resistance	10Hz to 55Hz 1.5mm DA	
Humidity	98%, +40°C	
Ambient temperature	-40°C to 85°C	
Termination	PCB	
Unit weight	Approx. 3g	
Construction	Flux proofed, Wash tight	

Notes: 1) The data shown above are initial values.

COIL

Coil power	200mW
------------	-------

COIL DATA

at 23°C

Nominal Voltage VDC	Pick-up Voltage VDC	Drop-out Voltage VDC	Max. Allowable Voltage VDC	Coil Resistance Ω
3	2.25	0.18	3.90	45 x (1±10%)
5	3.75	0.25	6.50	125 x (1±10%)
6	4.50	0.30	7.80	180 x (1±10%)
9	6.75	0.45	11.7	405 x (1±10%)
12	9.00	0.60	15.6	720 x (1±10%)
18	13.5	0.90	23.4	1620 x (1±10%)
24	18.0	1.20	31.2	2880 x (1±10%)

SAFETY APPROVAL RATINGS

UL&CUL	AgNi	10A 125VAC/250VAC at 85°C 10A 277VAC/30VDC at 85°C 7A 125VAC/250VAC at 105°C 7A 277VAC/30VDC at 105°C
	AgSnO ₂	10A 125VAC/250VAC at 85°C 10A 277VAC/30VDC at 85°C 7A 125VAC/250VAC at 85°C 7A 277VAC/30VDC at 85°C TV-3
VDE	AgNi	7A 250VAC/30VDC at 105°C 10A 250VAC/30VDC at 85°C
	AgSnO ₂	7A 250VAC/30VDC at 85°C 10A 250VAC/30VDC at 85°C

Notes: Only some typical ratings are listed above. If more details are required, please contact us.



HONGFA RELAY

ISO9001, ISO/TS16949, ISO14001, OHSAS18001, IECQ QC 080000 CERTIFIED

2009 Rev. 1.02

ORDERING INFORMATION

Type		HF46F-G / 12 -H S 1 T G (XXX)					
Coil voltage	3, 5, 6, 9, 12, 18, 24VDC						
Contact arrangement	H: 1 Form A						
Construction ¹⁾	S: Wash tight	Nil: Flux proofed					
Termination	1: type 1	2: type 2					
Contact material ²⁾	T: AgSnO ₂	Nil: AgNi					
Contact plating	G: Gold plated	Nil: No gold plated					
Customer special code							

Notes: 1) Under the ambience with dangerous gas like H₂S, SO₂ or NO₂, wash tight type is recommended; please test the relay in real applications. If the ambience allows, flux proofed is preferentially recommended.

2) For the application of lamp (except LED), capacitive load, motor load or which can bring high inrush current when relay contacts connect instantly, AgSnO₂ contact material is recommended on priority.

OUTLINE DIMENSIONS, WIRING DIAGRAM AND PC BOARD LAYOUT

Unit: mm

Outline Dimensions

HF46F-G/□□-H□1□□ (□□□)

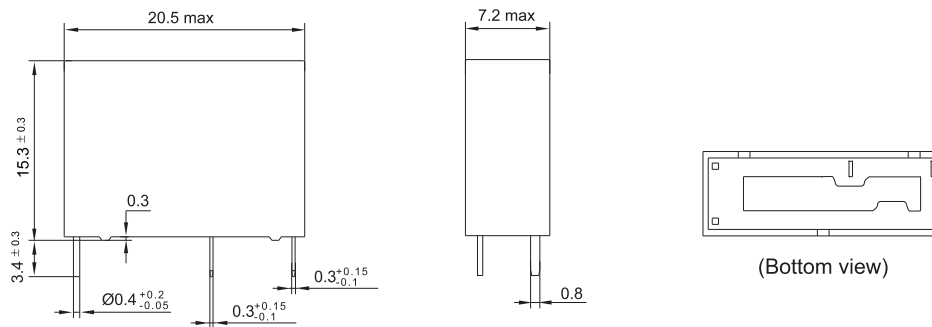

PCB Layout (Bottom view)

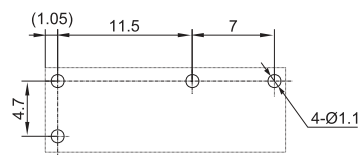

Wiring Diagram (Bottom view)

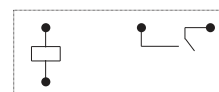

OUTLINE DIMENSIONS, WIRING DIAGRAM AND PC BOARD LAYOUT

Unit: mm

Outline Dimensions

HF46F-G/□□-H□2□□ (□□□)

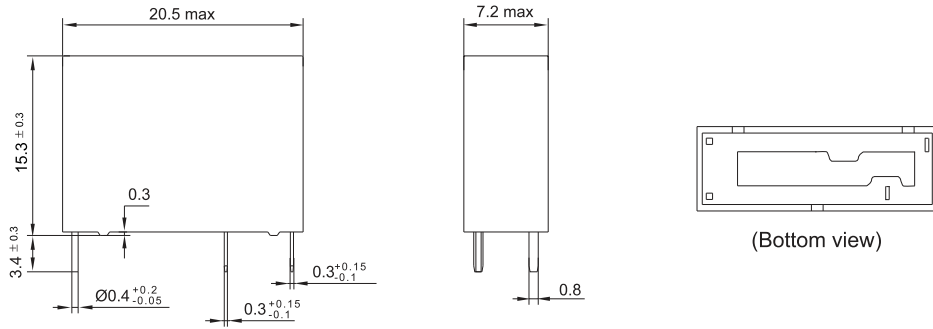

PCB Layout (Bottom view)

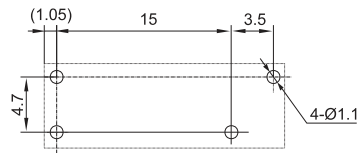

Wiring Diagram (Bottom view)



Remark: 1) In case of no tolerance shown in outline dimension: outline dimension $\leq 1\text{mm}$, tolerance should be $\pm 0.2\text{mm}$; outline dimension $> 1\text{mm}$ and $\leq 5\text{mm}$, tolerance should be $\pm 0.3\text{mm}$; outline dimension $> 5\text{mm}$, tolerance should be $\pm 0.4\text{mm}$.
2) The tolerance without indicating for PCB layout is always $\pm 0.1\text{mm}$.

CHARACTERISTIC CURVES

ENDURANCE CURVE

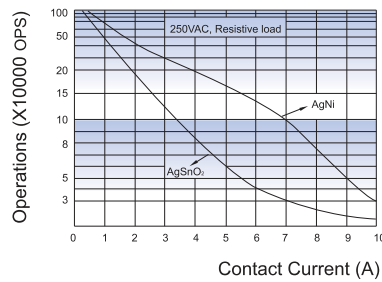

Disclaimer

This datasheet is for the customers' reference. All the specifications are subject to change without notice. We could not evaluate all the performance and all the parameters for every possible application. Thus the user should be in a right position to choose the suitable product for their own application. If there is any query, please contact Hongfa for the technical service. However, it is the user's responsibility to determine which product should be used only.

© Xiamen Hongfa Electroacoustic Co., Ltd. All rights of Hongfa are reserved.