

TIP125/126/127

Medium Power Linear Switching Applications

- Complementary to TIP120/121/122

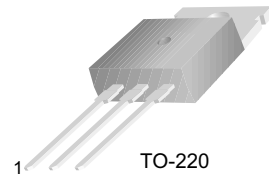

TO-220
1.Base 2.Collector 3.Emitter

PNP Epitaxial Darlington Transistor

Absolute Maximum Ratings $T_C=25^\circ\text{C}$ unless otherwise noted

| Symbol | Parameter | Value | Units |
|-----------|--|------------|------------------|
| V_{CBO} | Collector-Base Voltage : TIP125 | - 60 | V |
| | : TIP126 | - 80 | V |
| | : TIP127 | - 100 | V |
| V_{CEO} | Collector-Emitter Voltage : TIP125 | - 60 | V |
| | : TIP126 | - 80 | V |
| | : TIP127 | - 100 | V |
| V_{EBO} | Emitter-Base Voltage | - 5 | V |
| I_C | Collector Current (DC) | - 5 | A |
| I_{CP} | Collector Current (Pulse) | - 8 | A |
| I_B | Base Current (DC) | - 120 | mA |
| P_C | Collector Dissipation ($T_a=25^\circ\text{C}$) | 2 | W |
| | Collector Dissipation ($T_C=25^\circ\text{C}$) | 65 | W |
| T_J | Junction Temperature | 150 | $^\circ\text{C}$ |
| T_{STG} | Storage Temperature | - 65 ~ 150 | $^\circ\text{C}$ |

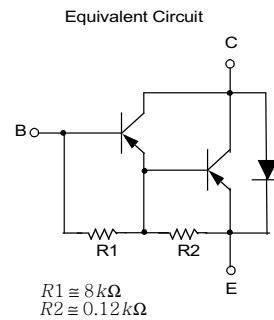

Electrical Characteristics $T_C=25^\circ\text{C}$ unless otherwise noted

| Symbol | Parameter | Test Condition | Min. | Max. | Units | |
|----------------|---|--|------|------|-------|---|
| $V_{CEO(sus)}$ | Collector-Emitter Sustaining Voltage : TIP125 | $I_C = -100\text{mA}, I_B = 0$ | -60 | | V | |
| | : TIP126 | | | | -80 | V |
| | : TIP127 | | | | -120 | V |
| I_{CEO} | Collector Cut-off Current : TIP125 | $V_{CE} = -30\text{V}, I_B = 0$ | | -2 | mA | |
| | : TIP126 | $V_{CE} = -40\text{V}, I_B = 0$ | | -2 | mA | |
| | : TIP127 | $V_{CE} = -50\text{V}, I_B = 0$ | | -2 | mA | |
| I_{CBO} | Collector Cut-off Current : TIP125 | $V_{CB} = -60\text{V}, I_E = 0$ | | -1 | mA | |
| | : TIP126 | $V_{CB} = -80\text{V}, I_E = 0$ | | -1 | mA | |
| | : TIP127 | $V_{CB} = -100\text{V}, I_E = 0$ | | -1 | mA | |
| I_{EBO} | Emitter Cut-off Current | $V_{BE} = -5\text{V}, I_C = 0$ | | -2 | mA | |
| h_{FE} | * DC Current Gain | $V_{CE} = -3\text{V}, I_C = 0.5\text{A}$ | 1000 | | | |
| | | $V_{CE} = -3\text{V}, I_C = -3\text{A}$ | 1000 | | | |
| $V_{CE(sat)}$ | * Collector-Emitter Saturation Voltage | $I_C = -3\text{A}, I_B = -12\text{mA}$ | | -2 | V | |
| | | $I_C = -5\text{A}, I_B = -20\text{mA}$ | | -4 | V | |
| $V_{BE(on)}$ | * Base-Emitter ON Voltage | $V_{CE} = -3\text{V}, I_C = -3\text{A}$ | | -2.5 | V | |
| C_{ob} | Output Capacitance | $V_{CB} = -10\text{V}, I_E = 0, f = 0.1\text{MHz}$ | | 300 | pF | |

* Pulse Test : $PW \leq 300\mu\text{s}$, Duty cycle $\leq 2\%$

Typical Characteristics

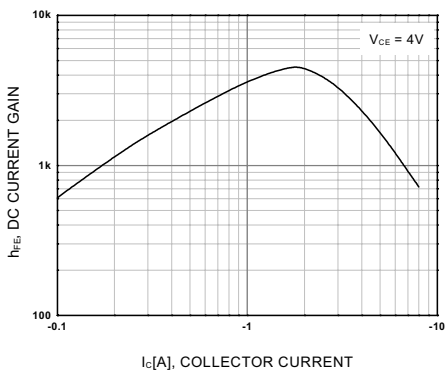

Figure 1. DC current Gain

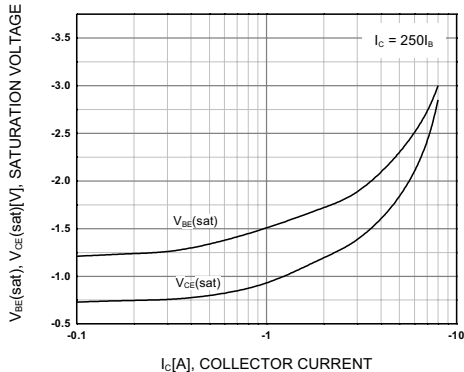

Figure 2. Base-Emitter Saturation Voltage
Collector-Emitter Saturation Voltage

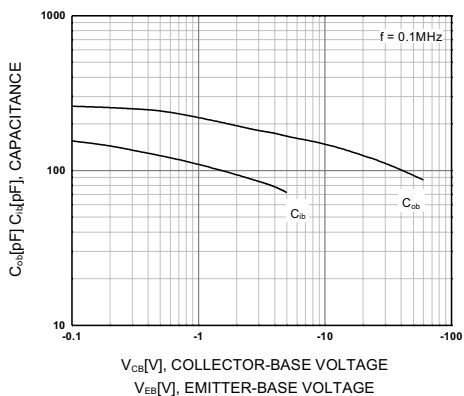

Figure 3. Output and Input Capacitance
vs. Reverse Voltage

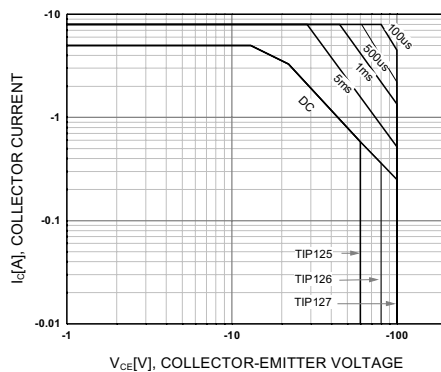

Figure 4. Safe Operating Area

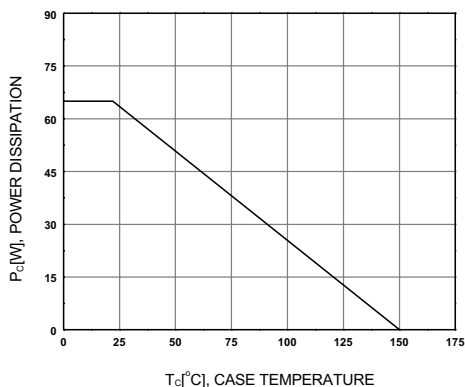
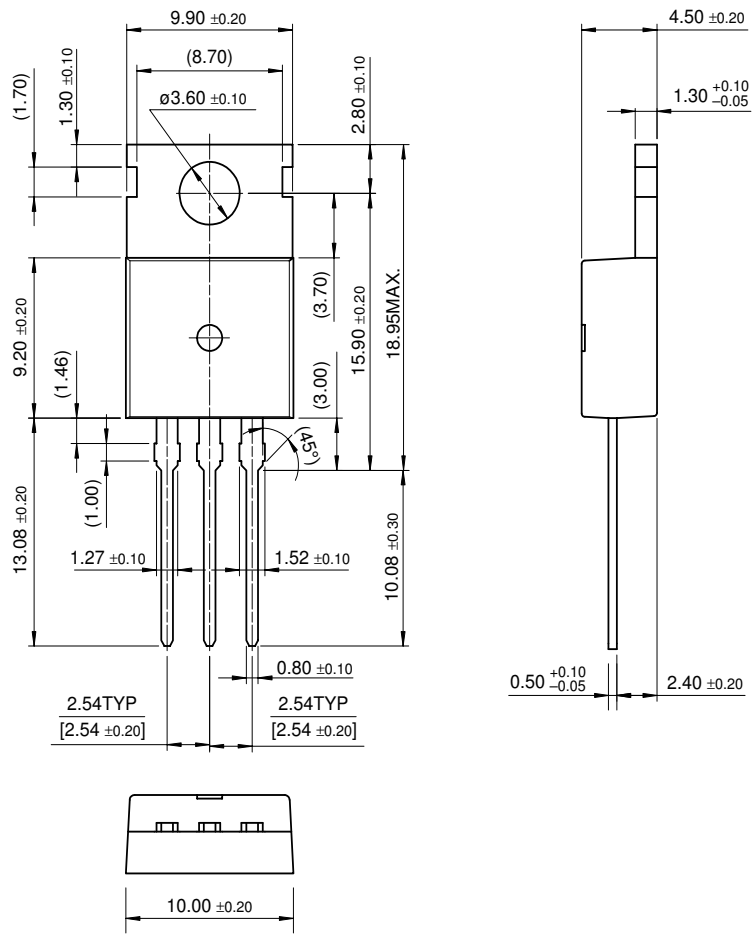

Figure 5. Power Derating

Package Dimensions

TO-220

TIP125/126/127



Dimensions in Millimeters