

120X120X25 mm

SUNON

46-80 CFM



Model	P/N	Bearing	Rating Voltage (VAC)	Freq. (Hz)	Power Current (AMP)	Power Consumption (WATTS)	Speed (RPM)	Air Flow (CFM)	Static Pressure (Inch-H ₂ O)	Noise (dBA)	Weight (g)
SP101AT	1122HSL.GN	● VAPOR BALL	115	50/60	0.21/0.19	19/18	2000/2300	64/78	0.13/0.16	43/46	330
SP101AT	1122HST.GN	○ BALL	115	50/60	0.21/0.19	19/18	2000/2300	64/78	0.13/0.16	43/46	330
SP103AT	1122LSL.GN	○ Sleeve	115	50/60	0.14/0.13	14/13	1600/1800	46/53	0.11/0.12	35/38	330
SP103AT	1122LST.GN	○ Sleeve	115	50/60	0.14/0.13	14/13	1600/1800	46/53	0.11/0.12	35/38	330
SP101AT	1122HBL.GN	○	115	50/60	0.21/0.19	19/18	2150/2500	66/80	0.14/0.17	44/48	330
SP101AT	1122HBT.GN	○	115	50/60	0.21/0.19	19/18	2150/2500	66/80	0.14/0.17	44/48	330
SP103AT	1122LBL.GN	○	115	50/60	0.12/0.11	12.5/11.5	1700/1900	47/54	0.12/0.13	37/40	330
SP103AT	1122LBT.GN	○	115	50/60	0.12/0.11	12.5/11.5	1700/1900	47/54	0.12/0.13	37/40	330

Frame : Aluminum alloy

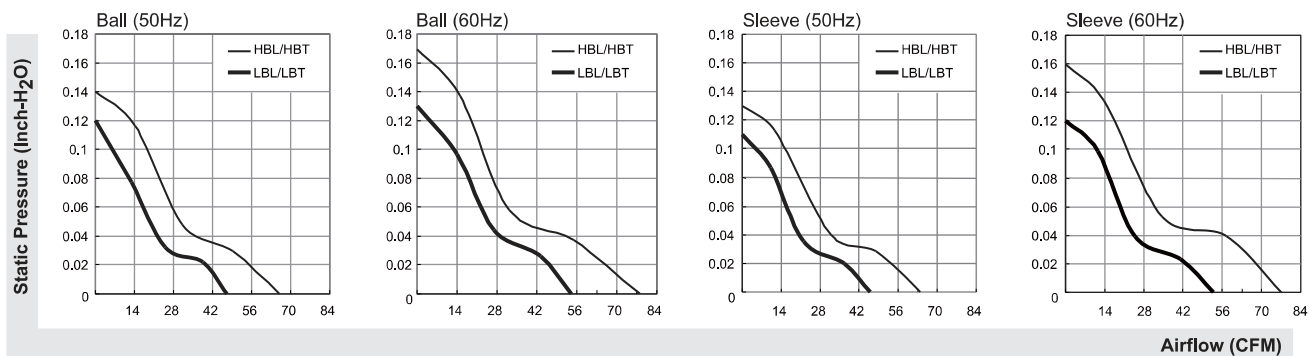

UNITS:mm

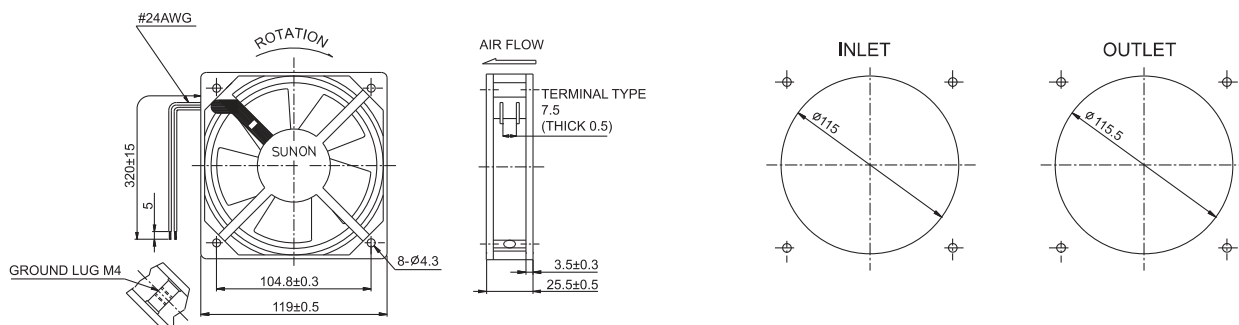

*All model could be customized on voltage or any other requirements to fit your need.

*Specifications subject to change without notice. Please Visit SUNON web site at <http://www.sunon.com> for update information.

120X120X25 mm

SUNON

46-80 CFM



Model	P/N	Bearing	Rating Voltage (VAC)	Freq. (Hz)	Power Current (AMP)	Power Consumption (WATTS)	Speed (RPM)	Air Flow (CFM)	Static Pressure (Inch-H ₂ O)	Noise (dBA)	Weight (g)
DP201AT	2122HSL.GN	● VAPO	220-240	50/60	0.10/0.09	19/19	2000/2300	64/78	0.13/0.16	43/46	330
DP201AT	2122HST.GN	○ BALL	220-240	50/60	0.10/0.09	19/19	2000/2300	64/78	0.13/0.16	43/46	330
DP203AT	2122LSL.GN	○ BALL	220-240	50/60	0.07/0.07	14/13	1600/1800	46/53	0.11/0.12	35/38	330
DP203AT	2122LST.GN	○ BALL	220-240	50/60	0.07/0.07	14/13	1600/1800	46/53	0.11/0.12	35/38	330
DP201AT	2122HBL.GN	○ Sleeve	220-240	50/60	0.10/0.09	19/18	2150/2500	66/80	0.14/0.17	44/48	330
DP201AT	2122HBT.GN	○ Sleeve	220-240	50/60	0.10/0.09	19/18	2150/2500	66/80	0.14/0.17	44/48	330
DP203AT	2122LBL.GN	○ Sleeve	220-240	50/60	0.07/0.07	14/13	1700/1900	47/54	0.12/0.13	37/40	330
DP203AT	2122LBT.GN	○ Sleeve	220-240	50/60	0.07/0.07	14/13	1700/1900	47/54	0.12/0.13	37/40	330

Frame : Aluminum alloy

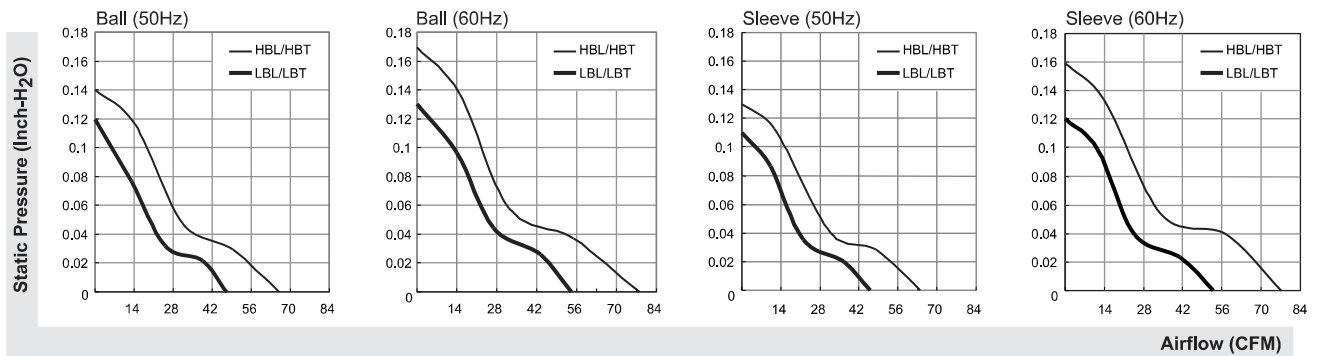

UNITS:mm

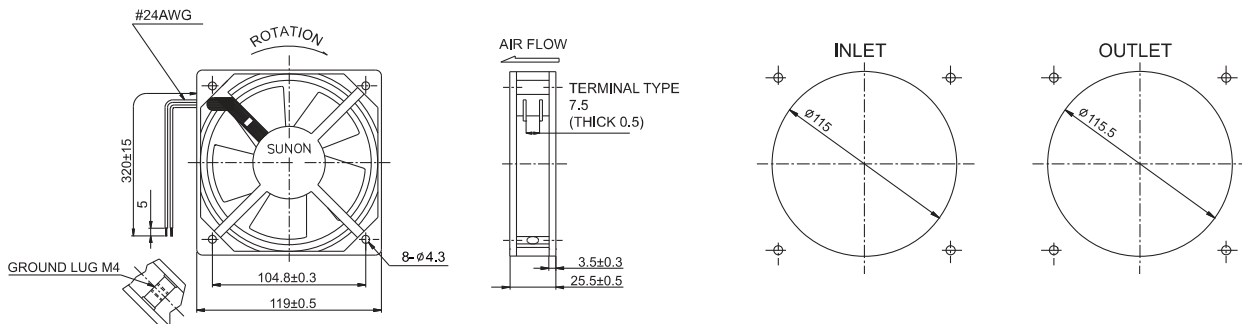

*All model could be customized on voltage or any other requirements to fit your need.

*Specifications subject to change without notice. Please Visit SUNON web site at <http://www.sunon.com> for update information.