

POSITIVE VOLTAGE REGULATORS

- OUTPUT CURRENT TO 1.5A
- OUTPUT VOLTAGES OF 5; 5.2; 6; 8; 8.5; 9; 10; 12; 15; 18; 24V
- THERMAL OVERLOAD PROTECTION
- SHORT CIRCUIT PROTECTION
- OUTPUT TRANSITION SOA PROTECTION

DESCRIPTION

The L7800 series of three-terminal positive regulators is available in TO-220, TO-220FP, TO-220FM, TO-3 and D²PAK packages and several fixed output voltages, making it useful in a wide range of applications. These regulators can provide local on-card regulation, eliminating the distribution problems associated with single point regulation. Each type employs internal current limiting, thermal shut-down and safe area protection, making it essentially indestructible. If adequate heat sinking is provided, they can deliver over 1A output current. Although designed primarily as fixed voltage regulators, these devices can be used with external components to obtain adjustable voltage and currents.

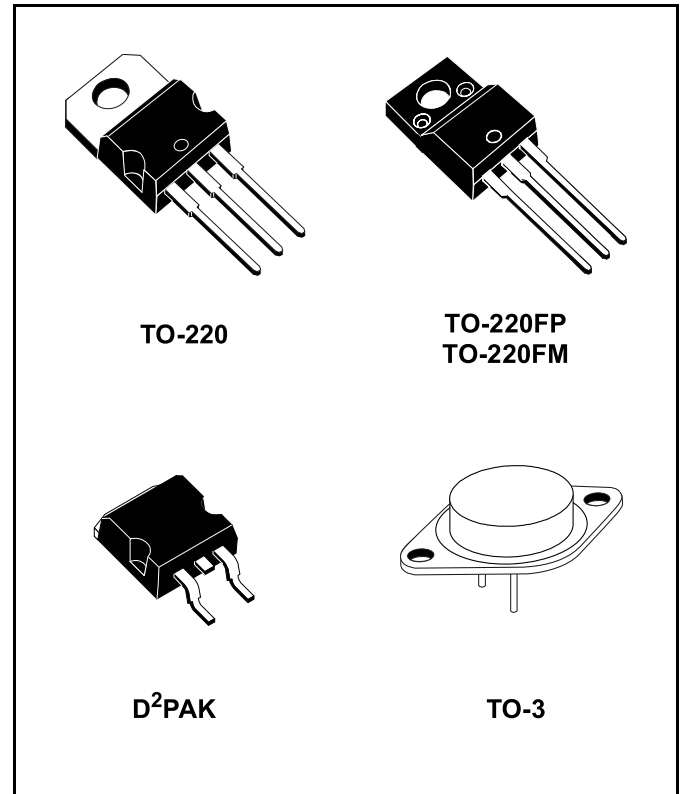

Figure 1: Schematic Diagram

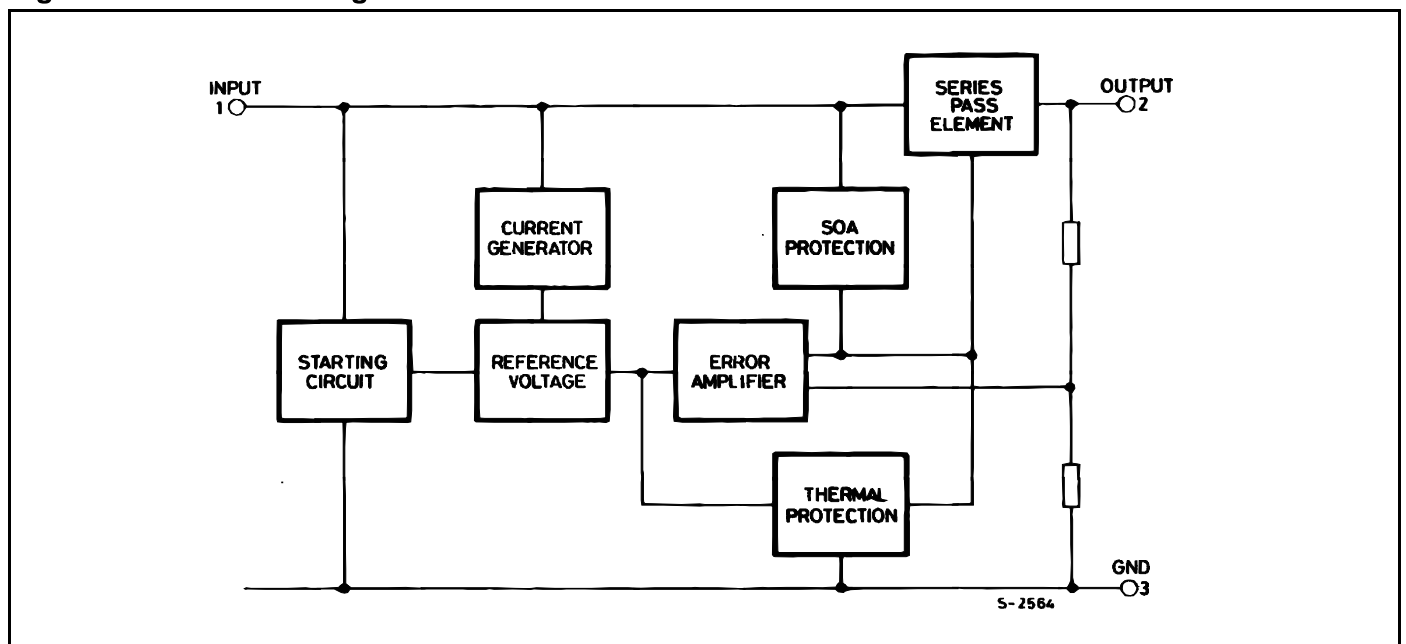

Table 1: Absolute Maximum Ratings

Symbol	Parameter		Value	Unit
V_I	DC Input Voltage	for $V_O = 5$ to 18V	35	V
		for $V_O = 20, 24V$	40	
I_O	Output Current		Internally Limited	
P_{tot}	Power Dissipation		Internally Limited	
T_{stg}	Storage Temperature Range		-65 to 150	°C
T_{op}	Operating Junction Temperature Range	for L7800	-55 to 150	°C
		for L7800C	0 to 150	

Absolute Maximum Ratings are those values beyond which damage to the device may occur. Functional operation under these condition is not implied.

Table 2: Thermal Data

Symbol	Parameter	D ² PAK	TO-220	TO-220FP	TO-220FM	TO-3	Unit
$R_{thj-case}$	Thermal Resistance Junction-case Max	3	5	5	5	4	°C/W
$R_{thj-amb}$	Thermal Resistance Junction-ambient Max	62.5	50	60	60	35	°C/W

Figure 2: Schematic Diagram

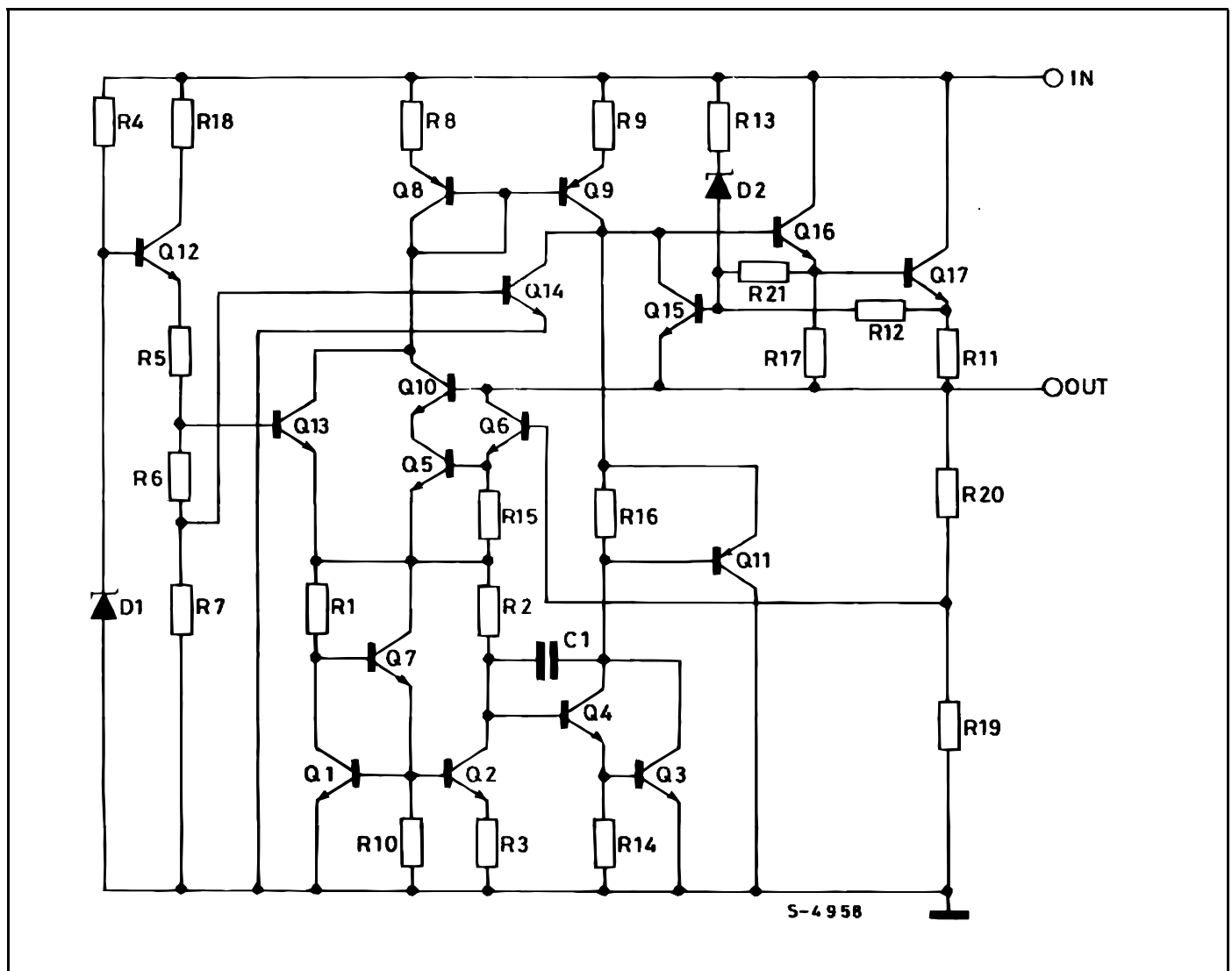

Figure 3: Connection Diagram (top view)

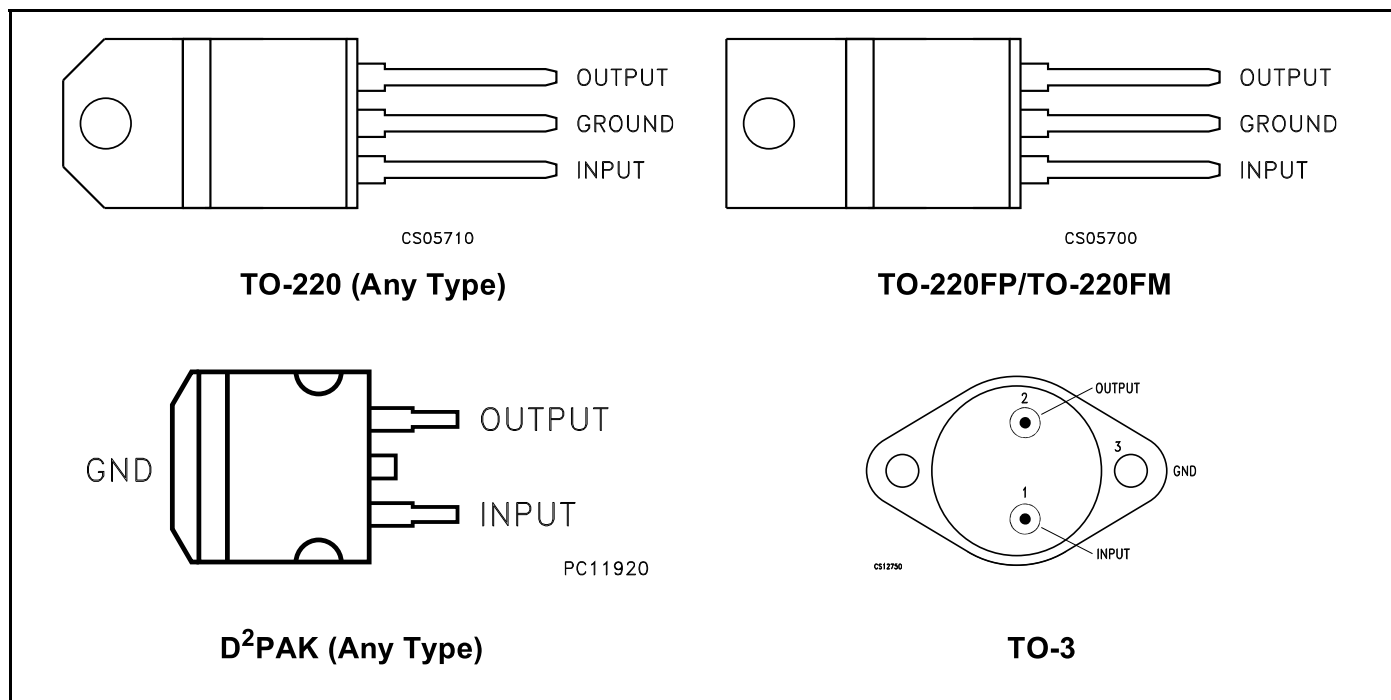
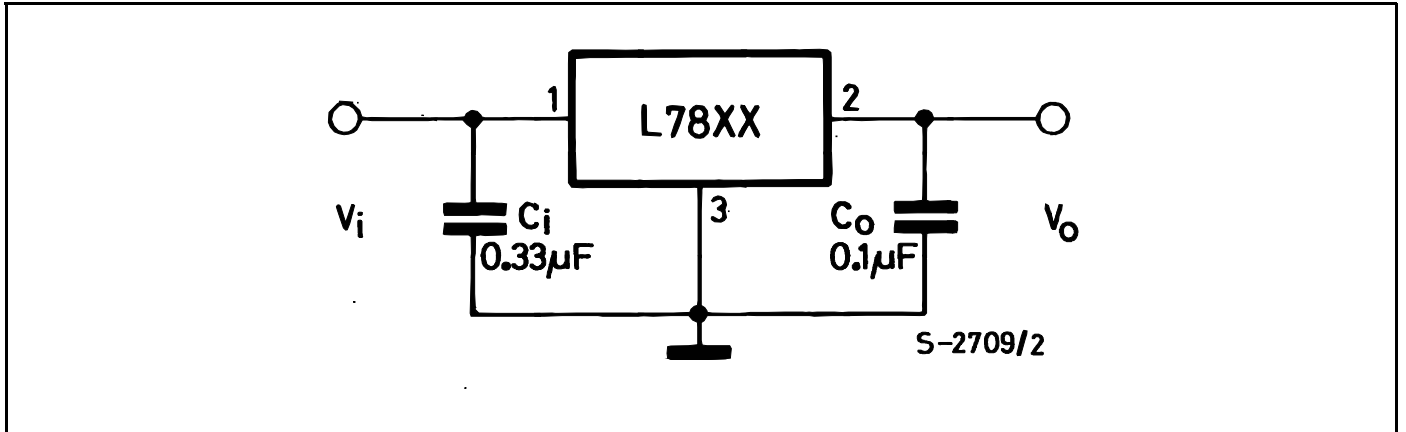

Table 3: Order Codes

TYPE	TO-220 (A Type)	TO-220 (C Type)	TO-220 (E Type)	D ² PAK (A Type) (*)	D ² PAK (C Type) (T & R)	TO-220FP	TO-220FM	TO-3
L7805								L7805T
L7805C	L7805CV	L7805C-V	L7805CV1	L7805CD2T	L7805C-D2TR	L7805CP	L7805CF	L7805CT
L7852C	L7852CV			L7852CD2T		L7852CP	L7852CF	L7852CT
L7806								L7806T
L7806C	L7806CV	L7806C-V		L7806CD2T		L7806CP	L7806CF	L7806CT
L7808								L7808T
L7808C	L7808CV	L7808C-V		L7808CD2T		L7808CP	L7808CF	L7808CT
L7885C	L7885CV			L7885CD2T		L7885CP	L7885CF	L7885CT
L7809C	L7809CV	L7809C-V		L7809CD2T		L7809CP	L7809CF	L7809CT
L7810C	L7810CV			L7810CD2T		L7810CP		
L7812								L7812T
L7812C	L7812CV	L7812C-V		L7812CD2T		L7812CP	L7812CF	L7812CT
L7815								L7815T
L7815C	L7815CV	L7815C-V		L7815CD2T		L7815CP	L7815CF	L7815CT
L7818								L7818T
L7818C	L7818CV			L7818CD2T		L7818CP	L7818CF	L7818CT
L7820								L7820T
L7820C	L7820CV			L7820CD2T		L7820CP	L7820CF	L7820CT
L7824								L7824T
L7824C	L7824CV			L7824CD2T		L7824CP	L7824CF	L7824CT

(*) Available in Tape & Reel with the suffix "-TR".

Figure 4: Application Circuits



TEST CIRCUITS

Figure 5: DC Parameter

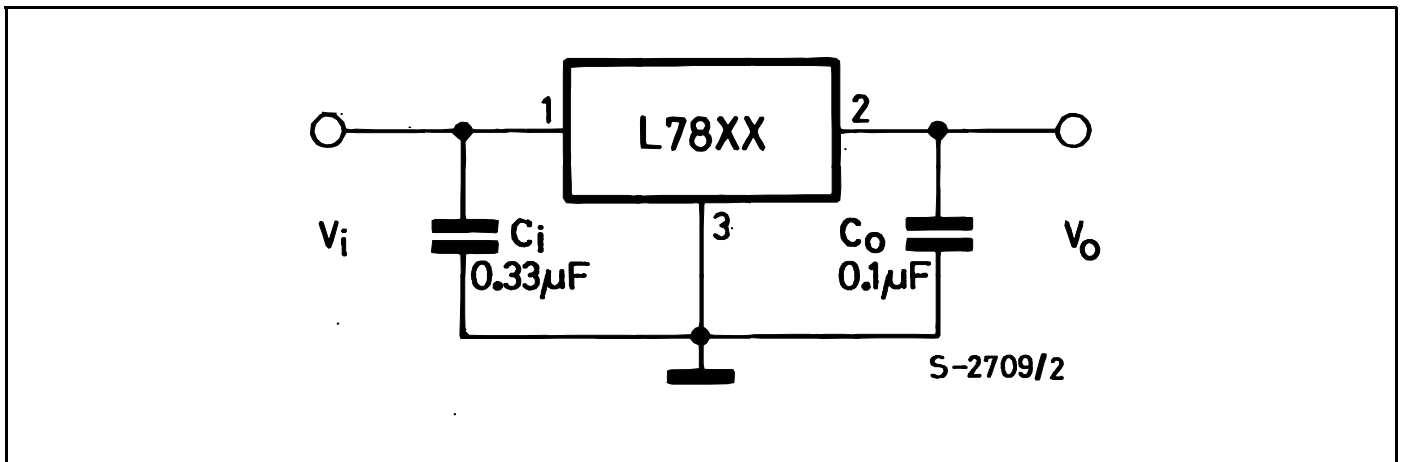

Figure 6: Load Regulation

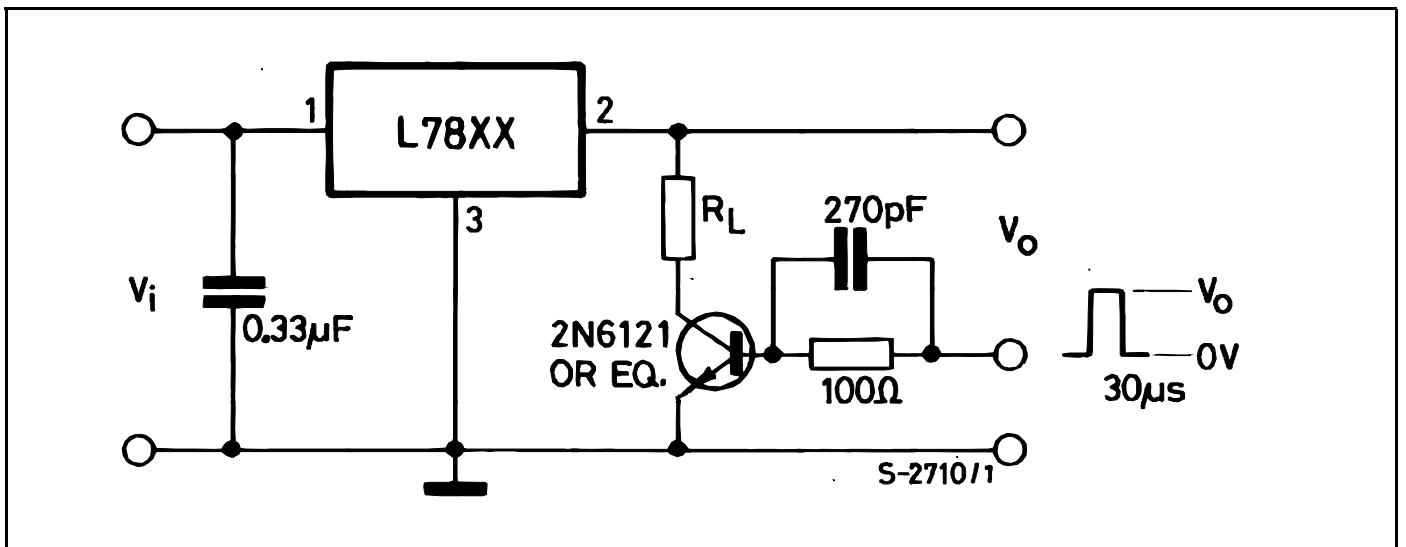

Figure 7: Ripple Rejection

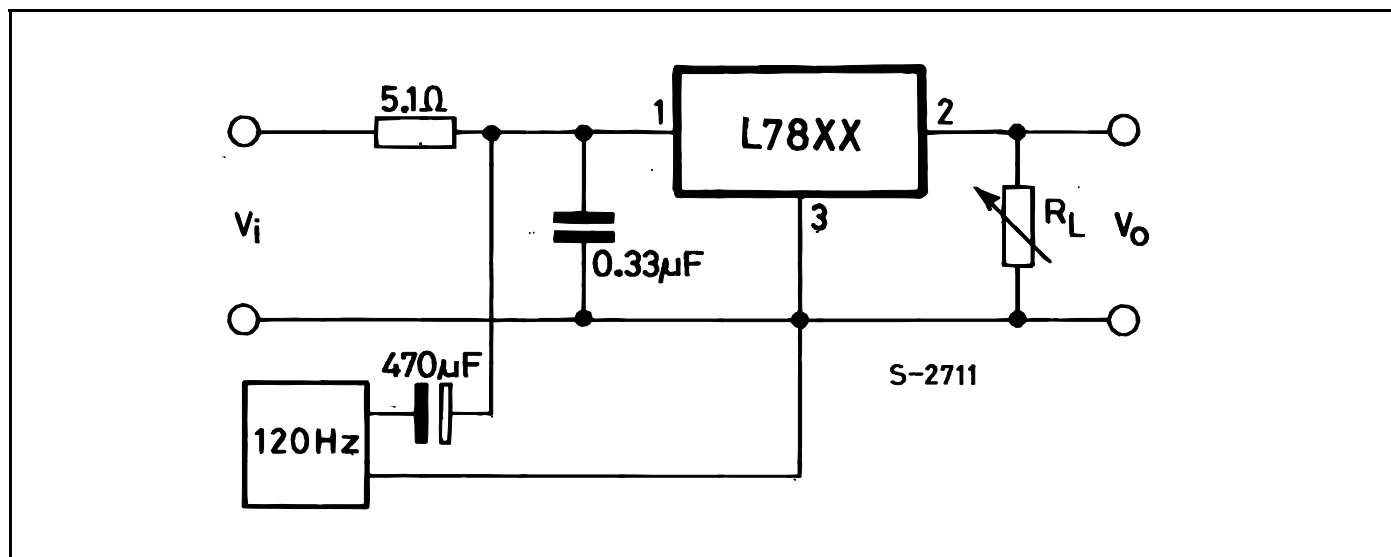

Table 4: Electrical Characteristics Of L7805 (refer to the test circuits, $T_J = -55$ to 150°C , $V_I = 10\text{V}$, $I_O = 500\text{ mA}$, $C_I = 0.33\ \mu\text{F}$, $C_O = 0.1\ \mu\text{F}$ unless otherwise specified).

Symbol	Parameter	Test Conditions	Min.	Typ.	Max.	Unit
V_O	Output Voltage	$T_J = 25^\circ\text{C}$	4.8	5	5.2	V
V_O	Output Voltage	$I_O = 5\text{ mA to } 1\text{ A}$ $P_O \leq 15\text{W}$ $V_I = 8\text{ to } 20\text{ V}$	4.65	5	5.35	V
$\Delta V_O(^*)$	Line Regulation	$V_I = 7\text{ to } 25\text{ V}$ $T_J = 25^\circ\text{C}$		3	50	mV
		$V_I = 8\text{ to } 12\text{ V}$ $T_J = 25^\circ\text{C}$		1	25	
$\Delta V_O(^*)$	Load Regulation	$I_O = 5\text{ mA to } 1.5\text{ A}$ $T_J = 25^\circ\text{C}$			100	mV
		$I_O = 250\text{ to } 750\text{ mA}$ $T_J = 25^\circ\text{C}$			25	
I_d	Quiescent Current	$T_J = 25^\circ\text{C}$			6	mA
ΔI_d	Quiescent Current Change	$I_O = 5\text{ mA to } 1\text{ A}$			0.5	mA
		$V_I = 8\text{ to } 25\text{ V}$			0.8	
$\Delta V_O/\Delta T$	Output Voltage Drift	$I_O = 5\text{ mA}$		0.6		mV/ $^\circ\text{C}$
eN	Output Noise Voltage	B = 10Hz to 100KHz $T_J = 25^\circ\text{C}$			40	$\mu\text{V}/V_O$
SVR	Supply Voltage Rejection	$V_I = 8\text{ to } 18\text{ V}$ $f = 120\text{Hz}$	68			dB
V_d	Dropout Voltage	$I_O = 1\text{ A}$ $T_J = 25^\circ\text{C}$		2	2.5	V
R_O	Output Resistance	$f = 1\text{ KHz}$		17		m Ω
I_{sc}	Short Circuit Current	$V_I = 35\text{ V}$ $T_J = 25^\circ\text{C}$		0.75	1.2	A
I_{scp}	Short Circuit Peak Current	$T_J = 25^\circ\text{C}$	1.3	2.2	3.3	A

(*) Load and line regulation are specified at constant junction temperature. Changes in V_O due to heating effects must be taken into account separately. Pulse testing with low duty cycle is used.

Table 5: Electrical Characteristics Of L7806 (refer to the test circuits, $T_J = -55$ to 150°C , $V_I = 11\text{V}$, $I_O = 500$ mA, $C_I = 0.33$ μF , $C_O = 0.1$ μF unless otherwise specified).

Symbol	Parameter	Test Conditions	Min.	Typ.	Max.	Unit
V_O	Output Voltage	$T_J = 25^\circ\text{C}$	5.75	6	6.25	V
V_O	Output Voltage	$I_O = 5$ mA to 1 A $P_O \leq 15\text{W}$ $V_I = 9$ to 21 V	5.65	6	6.35	V
$\Delta V_O(^*)$	Line Regulation	$V_I = 8$ to 25 V $T_J = 25^\circ\text{C}$			60	mV
		$V_I = 9$ to 13 V $T_J = 25^\circ\text{C}$			30	
$\Delta V_O(^*)$	Load Regulation	$I_O = 5$ mA to 1.5 A $T_J = 25^\circ\text{C}$			100	mV
		$I_O = 250$ to 750 mA $T_J = 25^\circ\text{C}$			30	
I_d	Quiescent Current	$T_J = 25^\circ\text{C}$			6	mA
ΔI_d	Quiescent Current Change	$I_O = 5$ mA to 1 A			0.5	mA
		$V_I = 9$ to 25 V			0.8	
$\Delta V_O/\Delta T$	Output Voltage Drift	$I_O = 5$ mA		0.7		mV/ $^\circ\text{C}$
eN	Output Noise Voltage	B = 10Hz to 100KHz $T_J = 25^\circ\text{C}$			40	$\mu\text{V}/V_O$
SVR	Supply Voltage Rejection	$V_I = 9$ to 19 V f = 120Hz	65			dB
V_d	Dropout Voltage	$I_O = 1$ A $T_J = 25^\circ\text{C}$		2	2.5	V
R_O	Output Resistance	f = 1 KHz		19		m Ω
I_{sc}	Short Circuit Current	$V_I = 35$ V $T_J = 25^\circ\text{C}$		0.75	1.2	A
I_{scp}	Short Circuit Peak Current	$T_J = 25^\circ\text{C}$	1.3	2.2	3.3	A

(*) Load and line regulation are specified at constant junction temperature. Changes in V_O due to heating effects must be taken into account separately. Pulse testing with low duty cycle is used.

Table 6: Electrical Characteristics Of L7808 (refer to the test circuits, $T_J = -55$ to 150°C , $V_I = 14\text{V}$, $I_O = 500$ mA, $C_I = 0.33$ μF , $C_O = 0.1$ μF unless otherwise specified).

Symbol	Parameter	Test Conditions	Min.	Typ.	Max.	Unit
V_O	Output Voltage	$T_J = 25^\circ\text{C}$	7.7	8	8.3	V
V_O	Output Voltage	$I_O = 5$ mA to 1 A $P_O \leq 15\text{W}$ $V_I = 11.5$ to 23 V	7.6	8	8.4	V
$\Delta V_O(^*)$	Line Regulation	$V_I = 10.5$ to 25 V $T_J = 25^\circ\text{C}$			80	mV
		$V_I = 11$ to 17 V $T_J = 25^\circ\text{C}$			40	
$\Delta V_O(^*)$	Load Regulation	$I_O = 5$ mA to 1.5 A $T_J = 25^\circ\text{C}$			100	mV
		$I_O = 250$ to 750 mA $T_J = 25^\circ\text{C}$			40	
I_d	Quiescent Current	$T_J = 25^\circ\text{C}$			6	mA
ΔI_d	Quiescent Current Change	$I_O = 5$ mA to 1 A			0.5	mA
		$V_I = 11.5$ to 25 V			0.8	
$\Delta V_O/\Delta T$	Output Voltage Drift	$I_O = 5$ mA		1		mV/ $^\circ\text{C}$
eN	Output Noise Voltage	B = 10Hz to 100KHz $T_J = 25^\circ\text{C}$			40	$\mu\text{V}/V_O$
SVR	Supply Voltage Rejection	$V_I = 11.5$ to 21.5 V f = 120Hz	62			dB
V_d	Dropout Voltage	$I_O = 1$ A $T_J = 25^\circ\text{C}$		2	2.5	V
R_O	Output Resistance	f = 1 KHz		16		m Ω
I_{sc}	Short Circuit Current	$V_I = 35$ V $T_J = 25^\circ\text{C}$		0.75	1.2	A
I_{scp}	Short Circuit Peak Current	$T_J = 25^\circ\text{C}$	1.3	2.2	3.3	A

(*) Load and line regulation are specified at constant junction temperature. Changes in V_O due to heating effects must be taken into account separately. Pulse testing with low duty cycle is used.

Table 7: Electrical Characteristics Of L7812 (refer to the test circuits, $T_J = -55$ to 150°C , $V_I = 19\text{V}$, $I_O = 500$ mA, $C_I = 0.33$ μF , $C_O = 0.1$ μF unless otherwise specified).

Symbol	Parameter	Test Conditions	Min.	Typ.	Max.	Unit
V_O	Output Voltage	$T_J = 25^\circ\text{C}$	11.5	12	12.5	V
V_O	Output Voltage	$I_O = 5$ mA to 1 A $P_O \leq 15\text{W}$ $V_I = 15.5$ to 27 V	11.4	12	12.6	V
ΔV_O (*)	Line Regulation	$V_I = 14.5$ to 30 V $T_J = 25^\circ\text{C}$			120	mV
		$V_I = 16$ to 22 V $T_J = 25^\circ\text{C}$			60	
ΔV_O (*)	Load Regulation	$I_O = 5$ mA to 1.5 A $T_J = 25^\circ\text{C}$			100	mV
		$I_O = 250$ to 750 mA $T_J = 25^\circ\text{C}$			60	
I_d	Quiescent Current	$T_J = 25^\circ\text{C}$			6	mA
ΔI_d	Quiescent Current Change	$I_O = 5$ mA to 1 A			0.5	mA
		$V_I = 15$ to 30 V			0.8	
$\Delta V_O/\Delta T$	Output Voltage Drift	$I_O = 5$ mA		1.5		mV/ $^\circ\text{C}$
eN	Output Noise Voltage	B = 10Hz to 100KHz $T_J = 25^\circ\text{C}$			40	$\mu\text{V}/V_O$
SVR	Supply Voltage Rejection	$V_I = 15$ to 25 V $f = 120\text{Hz}$	61			dB
V_d	Dropout Voltage	$I_O = 1$ A $T_J = 25^\circ\text{C}$		2	2.5	V
R_O	Output Resistance	$f = 1$ KHz		18		m Ω
I_{sc}	Short Circuit Current	$V_I = 35$ V $T_J = 25^\circ\text{C}$		0.75	1.2	A
I_{scp}	Short Circuit Peak Current	$T_J = 25^\circ\text{C}$	1.3	2.2	3.3	A

(*) Load and line regulation are specified at constant junction temperature. Changes in V_O due to heating effects must be taken into account separately. Pulse testing with low duty cycle is used.

Table 8: Electrical Characteristics Of L7815 (refer to the test circuits, $T_J = -55$ to 150°C , $V_I = 23\text{V}$, $I_O = 500$ mA, $C_I = 0.33$ μF , $C_O = 0.1$ μF unless otherwise specified).

Symbol	Parameter	Test Conditions	Min.	Typ.	Max.	Unit
V_O	Output Voltage	$T_J = 25^\circ\text{C}$	14.4	15	15.6	V
V_O	Output Voltage	$I_O = 5$ mA to 1 A $P_O \leq 15\text{W}$ $V_I = 18.5$ to 30 V	14.25	15	15.75	V
ΔV_O (*)	Line Regulation	$V_I = 17.5$ to 30 V $T_J = 25^\circ\text{C}$			150	mV
		$V_I = 20$ to 26 V $T_J = 25^\circ\text{C}$			75	
ΔV_O (*)	Load Regulation	$I_O = 5$ mA to 1.5 A $T_J = 25^\circ\text{C}$			150	mV
		$I_O = 250$ to 750 mA $T_J = 25^\circ\text{C}$			75	
I_d	Quiescent Current	$T_J = 25^\circ\text{C}$			6	mA
ΔI_d	Quiescent Current Change	$I_O = 5$ mA to 1 A			0.5	mA
		$V_I = 18.5$ to 30 V			0.8	
$\Delta V_O/\Delta T$	Output Voltage Drift	$I_O = 5$ mA		1.8		mV/ $^\circ\text{C}$
eN	Output Noise Voltage	B = 10Hz to 100KHz $T_J = 25^\circ\text{C}$			40	$\mu\text{V}/V_O$
SVR	Supply Voltage Rejection	$V_I = 18.5$ to 28.5 V $f = 120\text{Hz}$	60			dB
V_d	Dropout Voltage	$I_O = 1$ A $T_J = 25^\circ\text{C}$		2	2.5	V
R_O	Output Resistance	$f = 1$ KHz		19		m Ω
I_{sc}	Short Circuit Current	$V_I = 35$ V $T_J = 25^\circ\text{C}$		0.75	1.2	A
I_{scp}	Short Circuit Peak Current	$T_J = 25^\circ\text{C}$	1.3	2.2	3.3	A

(*) Load and line regulation are specified at constant junction temperature. Changes in V_O due to heating effects must be taken into account separately. Pulse testing with low duty cycle is used.

Table 9: Electrical Characteristics Of L7818 (refer to the test circuits, $T_J = -55$ to 150°C , $V_I = 26\text{V}$, $I_O = 500$ mA, $C_I = 0.33$ μF , $C_O = 0.1$ μF unless otherwise specified).

Symbol	Parameter	Test Conditions	Min.	Typ.	Max.	Unit
V_O	Output Voltage	$T_J = 25^\circ\text{C}$	17.3	18	18.7	V
V_O	Output Voltage	$I_O = 5$ mA to 1 A $P_O \leq 15\text{W}$ $V_I = 22$ to 33 V	17.1	18	18.9	V
$\Delta V_O(^*)$	Line Regulation	$V_I = 21$ to 33 V $T_J = 25^\circ\text{C}$			180	mV
		$V_I = 24$ to 30 V $T_J = 25^\circ\text{C}$			90	
$\Delta V_O(^*)$	Load Regulation	$I_O = 5$ mA to 1.5 A $T_J = 25^\circ\text{C}$			180	mV
		$I_O = 250$ to 750 mA $T_J = 25^\circ\text{C}$			90	
I_d	Quiescent Current	$T_J = 25^\circ\text{C}$			6	mA
ΔI_d	Quiescent Current Change	$I_O = 5$ mA to 1 A			0.5	mA
		$V_I = 22$ to 33 V			0.8	
$\Delta V_O/\Delta T$	Output Voltage Drift	$I_O = 5$ mA		2.3		mV/ $^\circ\text{C}$
eN	Output Noise Voltage	B = 10Hz to 100KHz $T_J = 25^\circ\text{C}$			40	$\mu\text{V}/V_O$
SVR	Supply Voltage Rejection	$V_I = 22$ to 32 V $f = 120\text{Hz}$	59			dB
V_d	Dropout Voltage	$I_O = 1$ A $T_J = 25^\circ\text{C}$		2	2.5	V
R_O	Output Resistance	$f = 1$ KHz		22		m Ω
I_{sc}	Short Circuit Current	$V_I = 35$ V $T_J = 25^\circ\text{C}$		0.75	1.2	A
I_{scp}	Short Circuit Peak Current	$T_J = 25^\circ\text{C}$	1.3	2.2	3.3	A

(*) Load and line regulation are specified at constant junction temperature. Changes in V_O due to heating effects must be taken into account separately. Pulse testing with low duty cycle is used.

Table 10: Electrical Characteristics Of L7820 (refer to the test circuits, $T_J = -55$ to 150°C , $V_I = 28\text{V}$, $I_O = 500$ mA, $C_I = 0.33$ μF , $C_O = 0.1$ μF unless otherwise specified).

Symbol	Parameter	Test Conditions	Min.	Typ.	Max.	Unit
V_O	Output Voltage	$T_J = 25^\circ\text{C}$	19.2	20	20.8	V
V_O	Output Voltage	$I_O = 5$ mA to 1 A $P_O \leq 15\text{W}$ $V_I = 24$ to 35 V	19	20	21	V
$\Delta V_O(^*)$	Line Regulation	$V_I = 22.5$ to 35 V $T_J = 25^\circ\text{C}$			200	mV
		$V_I = 26$ to 32 V $T_J = 25^\circ\text{C}$			100	
$\Delta V_O(^*)$	Load Regulation	$I_O = 5$ mA to 1.5 A $T_J = 25^\circ\text{C}$			200	mV
		$I_O = 250$ to 750 mA $T_J = 25^\circ\text{C}$			100	
I_d	Quiescent Current	$T_J = 25^\circ\text{C}$			6	mA
ΔI_d	Quiescent Current Change	$I_O = 5$ mA to 1 A			0.5	mA
		$V_I = 24$ to 35 V			0.8	
$\Delta V_O/\Delta T$	Output Voltage Drift	$I_O = 5$ mA		2.5		mV/ $^\circ\text{C}$
eN	Output Noise Voltage	B = 10Hz to 100KHz $T_J = 25^\circ\text{C}$			40	$\mu\text{V}/V_O$
SVR	Supply Voltage Rejection	$V_I = 24$ to 35 V $f = 120\text{Hz}$	58			dB
V_d	Dropout Voltage	$I_O = 1$ A $T_J = 25^\circ\text{C}$		2	2.5	V
R_O	Output Resistance	$f = 1$ KHz		24		m Ω
I_{sc}	Short Circuit Current	$V_I = 35$ V $T_J = 25^\circ\text{C}$		0.75	1.2	A
I_{scp}	Short Circuit Peak Current	$T_J = 25^\circ\text{C}$	1.3	2.2	3.3	A

(*) Load and line regulation are specified at constant junction temperature. Changes in V_O due to heating effects must be taken into account separately. Pulse testing with low duty cycle is used.

Table 11: Electrical Characteristics Of L7824 (refer to the test circuits, $T_J = -55$ to 150°C , $V_I = 33\text{V}$, $I_O = 500$ mA, $C_I = 0.33$ μF , $C_O = 0.1$ μF unless otherwise specified).

Symbol	Parameter	Test Conditions	Min.	Typ.	Max.	Unit
V_O	Output Voltage	$T_J = 25^\circ\text{C}$	23	24	25	V
V_O	Output Voltage	$I_O = 5$ mA to 1 A $P_O \leq 15\text{W}$ $V_I = 28$ to 38 V	22.8	24	25.2	V
ΔV_O (*)	Line Regulation	$V_I = 27$ to 38 V $T_J = 25^\circ\text{C}$			240	mV
		$V_I = 30$ to 36 V $T_J = 25^\circ\text{C}$			120	
ΔV_O (*)	Load Regulation	$I_O = 5$ mA to 1.5 A $T_J = 25^\circ\text{C}$			240	mV
		$I_O = 250$ to 750 mA $T_J = 25^\circ\text{C}$			120	
I_d	Quiescent Current	$T_J = 25^\circ\text{C}$			6	mA
ΔI_d	Quiescent Current Change	$I_O = 5$ mA to 1 A			0.5	mA
		$V_I = 28$ to 38 V			0.8	
$\Delta V_O/\Delta T$	Output Voltage Drift	$I_O = 5$ mA		3		mV/ $^\circ\text{C}$
eN	Output Noise Voltage	B = 10Hz to 100KHz $T_J = 25^\circ\text{C}$			40	$\mu\text{V}/V_O$
SVR	Supply Voltage Rejection	$V_I = 28$ to 38 V $f = 120\text{Hz}$	56			dB
V_d	Dropout Voltage	$I_O = 1$ A $T_J = 25^\circ\text{C}$		2	2.5	V
R_O	Output Resistance	$f = 1$ KHz		28		m Ω
I_{sc}	Short Circuit Current	$V_I = 35$ V $T_J = 25^\circ\text{C}$		0.75	1.2	A
I_{scp}	Short Circuit Peak Current	$T_J = 25^\circ\text{C}$	1.3	2.2	3.3	A

(*) Load and line regulation are specified at constant junction temperature. Changes in V_O due to heating effects must be taken into account separately. Pulse testing with low duty cycle is used.

Table 12: Electrical Characteristics Of L7805C (refer to the test circuits, $T_J = 0$ to 125°C , $V_I = 10\text{V}$, $I_O = 500$ mA, $C_I = 0.33$ μF , $C_O = 0.1$ μF unless otherwise specified).

Symbol	Parameter	Test Conditions	Min.	Typ.	Max.	Unit
V_O	Output Voltage	$T_J = 25^\circ\text{C}$	4.8	5	5.2	V
V_O	Output Voltage	$I_O = 5$ mA to 1 A $P_O \leq 15\text{W}$ $V_I = 7$ to 20 V	4.75	5	5.25	V
ΔV_O (*)	Line Regulation	$V_I = 7$ to 25 V $T_J = 25^\circ\text{C}$		3	100	mV
		$V_I = 8$ to 12 V $T_J = 25^\circ\text{C}$		1	50	
ΔV_O (*)	Load Regulation	$I_O = 5$ mA to 1.5 A $T_J = 25^\circ\text{C}$			100	mV
		$I_O = 250$ to 750 mA $T_J = 25^\circ\text{C}$			50	
I_d	Quiescent Current	$T_J = 25^\circ\text{C}$			8	mA
ΔI_d	Quiescent Current Change	$I_O = 5$ mA to 1 A			0.5	mA
		$V_I = 7$ to 25 V			0.8	
$\Delta V_O/\Delta T$	Output Voltage Drift	$I_O = 5$ mA		-1.1		mV/ $^\circ\text{C}$
eN	Output Noise Voltage	B = 10Hz to 100KHz $T_J = 25^\circ\text{C}$		40		$\mu\text{V}/V_O$
SVR	Supply Voltage Rejection	$V_I = 8$ to 18 V $f = 120\text{Hz}$	62			dB
V_d	Dropout Voltage	$I_O = 1$ A $T_J = 25^\circ\text{C}$		2		V
R_O	Output Resistance	$f = 1$ KHz		17		m Ω
I_{sc}	Short Circuit Current	$V_I = 35$ V $T_J = 25^\circ\text{C}$		0.75		A
I_{scp}	Short Circuit Peak Current	$T_J = 25^\circ\text{C}$		2.2		A

(*) Load and line regulation are specified at constant junction temperature. Changes in V_O due to heating effects must be taken into account separately. Pulse testing with low duty cycle is used.

Table 13: Electrical Characteristics Of L7852C (refer to the test circuits, $T_J = 0$ to 125°C , $V_I = 10\text{V}$, $I_O = 500$ mA, $C_I = 0.33$ μF , $C_O = 0.1$ μF unless otherwise specified).

Symbol	Parameter	Test Conditions	Min.	Typ.	Max.	Unit
V_O	Output Voltage	$T_J = 25^\circ\text{C}$	5.0	5.2	5.4	V
V_O	Output Voltage	$I_O = 5$ mA to 1 A $P_O \leq 15\text{W}$ $V_I = 8$ to 20 V	4.95	5.2	5.45	V
$\Delta V_{O(*)}$	Line Regulation	$V_I = 7$ to 25 V $T_J = 25^\circ\text{C}$		3	105	mV
		$V_I = 8$ to 12 V $T_J = 25^\circ\text{C}$		1	52	
$\Delta V_{O(*)}$	Load Regulation	$I_O = 5$ mA to 1.5 A $T_J = 25^\circ\text{C}$			105	mV
		$I_O = 250$ to 750 mA $T_J = 25^\circ\text{C}$			52	
I_d	Quiescent Current	$T_J = 25^\circ\text{C}$			8	mA
ΔI_d	Quiescent Current Change	$I_O = 5$ mA to 1 A			0.5	mA
		$V_I = 7$ to 25 V			1.3	
$\Delta V_O/\Delta T$	Output Voltage Drift	$I_O = 5$ mA		-1		mV/ $^\circ\text{C}$
eN	Output Noise Voltage	B = 10Hz to 100KHz $T_J = 25^\circ\text{C}$		42		$\mu\text{V}/V_O$
SVR	Supply Voltage Rejection	$V_I = 8$ to 18 V f = 120Hz	61			dB
V_d	Dropout Voltage	$I_O = 1$ A $T_J = 25^\circ\text{C}$		2		V
R_O	Output Resistance	f = 1 KHz		17		m Ω
I_{sc}	Short Circuit Current	$V_I = 35$ V $T_J = 25^\circ\text{C}$		0.75		A
I_{scp}	Short Circuit Peak Current	$T_J = 25^\circ\text{C}$		2.2		A

(*) Load and line regulation are specified at constant junction temperature. Changes in V_O due to heating effects must be taken into account separately. Pulse testing with low duty cycle is used.

Table 14: Electrical Characteristics Of L7806C (refer to the test circuits, $T_J = 0$ to 125°C , $V_I = 11\text{V}$, $I_O = 500$ mA, $C_I = 0.33$ μF , $C_O = 0.1$ μF unless otherwise specified).

Symbol	Parameter	Test Conditions	Min.	Typ.	Max.	Unit
V_O	Output Voltage	$T_J = 25^\circ\text{C}$	5.75	6	6.25	V
V_O	Output Voltage	$I_O = 5$ mA to 1 A $P_O \leq 15\text{W}$ $V_I = 8$ to 21 V	5.7	6	6.3	V
$\Delta V_{O(*)}$	Line Regulation	$V_I = 8$ to 25 V $T_J = 25^\circ\text{C}$			120	mV
		$V_I = 9$ to 13 V $T_J = 25^\circ\text{C}$			60	
$\Delta V_{O(*)}$	Load Regulation	$I_O = 5$ mA to 1.5 A $T_J = 25^\circ\text{C}$			120	mV
		$I_O = 250$ to 750 mA $T_J = 25^\circ\text{C}$			60	
I_d	Quiescent Current	$T_J = 25^\circ\text{C}$			8	mA
ΔI_d	Quiescent Current Change	$I_O = 5$ mA to 1 A			0.5	mA
		$V_I = 8$ to 25 V			1.3	
$\Delta V_O/\Delta T$	Output Voltage Drift	$I_O = 5$ mA		-0.8		mV/ $^\circ\text{C}$
eN	Output Noise Voltage	B = 10Hz to 100KHz $T_J = 25^\circ\text{C}$		45		$\mu\text{V}/V_O$
SVR	Supply Voltage Rejection	$V_I = 9$ to 19 V f = 120Hz	59			dB
V_d	Dropout Voltage	$I_O = 1$ A $T_J = 25^\circ\text{C}$		2		V
R_O	Output Resistance	f = 1 KHz		19		m Ω
I_{sc}	Short Circuit Current	$V_I = 35$ V $T_J = 25^\circ\text{C}$		0.55		A
I_{scp}	Short Circuit Peak Current	$T_J = 25^\circ\text{C}$		2.2		A

(*) Load and line regulation are specified at constant junction temperature. Changes in V_O due to heating effects must be taken into account separately. Pulse testing with low duty cycle is used.

Table 15: Electrical Characteristics Of L7808C (refer to the test circuits, $T_J = 0$ to 125°C , $V_I = 14\text{V}$, $I_O = 500\text{ mA}$, $C_I = 0.33\text{ }\mu\text{F}$, $C_O = 0.1\text{ }\mu\text{F}$ unless otherwise specified).

Symbol	Parameter	Test Conditions	Min.	Typ.	Max.	Unit
V_O	Output Voltage	$T_J = 25^\circ\text{C}$	7.7	8	8.3	V
V_O	Output Voltage	$I_O = 5\text{ mA to }1\text{ A}$ $P_O \leq 15\text{W}$ $V_I = 10.5\text{ to }25\text{ V}$	7.6	8	8.4	V
$\Delta V_O(^*)$	Line Regulation	$V_I = 10.5\text{ to }25\text{ V}$ $T_J = 25^\circ\text{C}$			160	mV
		$V_I = 11\text{ to }17\text{ V}$ $T_J = 25^\circ\text{C}$			80	
$\Delta V_O(^*)$	Load Regulation	$I_O = 5\text{ mA to }1.5\text{ A}$ $T_J = 25^\circ\text{C}$			160	mV
		$I_O = 250\text{ to }750\text{ mA}$ $T_J = 25^\circ\text{C}$			80	
I_d	Quiescent Current	$T_J = 25^\circ\text{C}$			8	mA
ΔI_d	Quiescent Current Change	$I_O = 5\text{ mA to }1\text{ A}$			0.5	mA
		$V_I = 10.5\text{ to }25\text{ V}$			1	
$\Delta V_O/\Delta T$	Output Voltage Drift	$I_O = 5\text{ mA}$		-0.8		mV/ $^\circ\text{C}$
eN	Output Noise Voltage	$B = 10\text{Hz to }100\text{KHz}$ $T_J = 25^\circ\text{C}$		52		$\mu\text{V}/V_O$
SVR	Supply Voltage Rejection	$V_I = 11.5\text{ to }21.5\text{ V}$ $f = 120\text{Hz}$	56			dB
V_d	Dropout Voltage	$I_O = 1\text{ A}$ $T_J = 25^\circ\text{C}$		2		V
R_O	Output Resistance	$f = 1\text{ KHz}$		16		m Ω
I_{sc}	Short Circuit Current	$V_I = 35\text{ V}$ $T_J = 25^\circ\text{C}$		0.45		A
I_{scp}	Short Circuit Peak Current	$T_J = 25^\circ\text{C}$		2.2		A

(*) Load and line regulation are specified at constant junction temperature. Changes in V_O due to heating effects must be taken into account separately. Pulse testing with low duty cycle is used.

Table 16: Electrical Characteristics Of L7885C (refer to the test circuits, $T_J = 0$ to 125°C , $V_I = 14.5\text{V}$, $I_O = 500\text{ mA}$, $C_I = 0.33\text{ }\mu\text{F}$, $C_O = 0.1\text{ }\mu\text{F}$ unless otherwise specified).

Symbol	Parameter	Test Conditions	Min.	Typ.	Max.	Unit
V_O	Output Voltage	$T_J = 25^\circ\text{C}$	8.2	8.5	8.8	V
V_O	Output Voltage	$I_O = 5\text{ mA to }1\text{ A}$ $P_O \leq 15\text{W}$ $V_I = 11\text{ to }26\text{ V}$	8.1	8.5	8.9	V
$\Delta V_O(^*)$	Line Regulation	$V_I = 11\text{ to }27\text{ V}$ $T_J = 25^\circ\text{C}$			160	mV
		$V_I = 11.5\text{ to }17.5\text{ V}$ $T_J = 25^\circ\text{C}$			80	
$\Delta V_O(^*)$	Load Regulation	$I_O = 5\text{ mA to }1.5\text{ A}$ $T_J = 25^\circ\text{C}$			160	mV
		$I_O = 250\text{ to }750\text{ mA}$ $T_J = 25^\circ\text{C}$			80	
I_d	Quiescent Current	$T_J = 25^\circ\text{C}$			8	mA
ΔI_d	Quiescent Current Change	$I_O = 5\text{ mA to }1\text{ A}$			0.5	mA
		$V_I = 11\text{ to }27\text{ V}$			1	
$\Delta V_O/\Delta T$	Output Voltage Drift	$I_O = 5\text{ mA}$		-0.8		mV/ $^\circ\text{C}$
eN	Output Noise Voltage	$B = 10\text{Hz to }100\text{KHz}$ $T_J = 25^\circ\text{C}$		55		$\mu\text{V}/V_O$
SVR	Supply Voltage Rejection	$V_I = 12\text{ to }22\text{ V}$ $f = 120\text{Hz}$	56			dB
V_d	Dropout Voltage	$I_O = 1\text{ A}$ $T_J = 25^\circ\text{C}$		2		V
R_O	Output Resistance	$f = 1\text{ KHz}$		16		m Ω
I_{sc}	Short Circuit Current	$V_I = 35\text{ V}$ $T_J = 25^\circ\text{C}$		0.45		A
I_{scp}	Short Circuit Peak Current	$T_J = 25^\circ\text{C}$		2.2		A

(*) Load and line regulation are specified at constant junction temperature. Changes in V_O due to heating effects must be taken into account separately. Pulse testing with low duty cycle is used.

Table 17: Electrical Characteristics Of L7809C (refer to the test circuits, $T_J = 0$ to 125°C , $V_I = 15\text{V}$, $I_O = 500$ mA, $C_I = 0.33$ μF , $C_O = 0.1$ μF unless otherwise specified).

Symbol	Parameter	Test Conditions	Min.	Typ.	Max.	Unit
V_O	Output Voltage	$T_J = 25^\circ\text{C}$	8.64	9	9.36	V
V_O	Output Voltage	$I_O = 5$ mA to 1 A $P_O \leq 15\text{W}$ $V_I = 11.5$ to 26 V	8.55	9	9.45	V
ΔV_O (*)	Line Regulation	$V_I = 11.5$ to 26 V $T_J = 25^\circ\text{C}$			180	mV
		$V_I = 12$ to 18 V $T_J = 25^\circ\text{C}$			90	
ΔV_O (*)	Load Regulation	$I_O = 5$ mA to 1.5 A $T_J = 25^\circ\text{C}$			180	mV
		$I_O = 250$ to 750 mA $T_J = 25^\circ\text{C}$			90	
I_d	Quiescent Current	$T_J = 25^\circ\text{C}$			8	mA
ΔI_d	Quiescent Current Change	$I_O = 5$ mA to 1 A			0.5	mA
		$V_I = 11.5$ to 26 V			1	
$\Delta V_O/\Delta T$	Output Voltage Drift	$I_O = 5$ mA		-1		mV/ $^\circ\text{C}$
eN	Output Noise Voltage	B = 10Hz to 100KHz $T_J = 25^\circ\text{C}$		70		$\mu\text{V}/V_O$
SVR	Supply Voltage Rejection	$V_I = 12$ to 23 V $f = 120\text{Hz}$	55			dB
V_d	Dropout Voltage	$I_O = 1$ A $T_J = 25^\circ\text{C}$		2		V
R_O	Output Resistance	$f = 1$ KHz		17		m Ω
I_{sc}	Short Circuit Current	$V_I = 35$ V $T_J = 25^\circ\text{C}$		0.40		A
I_{scp}	Short Circuit Peak Current	$T_J = 25^\circ\text{C}$		2.2		A

(*) Load and line regulation are specified at constant junction temperature. Changes in V_O due to heating effects must be taken into account separately. Pulse testing with low duty cycle is used.

Table 18: Electrical Characteristics Of L7810C (refer to the test circuits, $T_J = 0$ to 125°C , $V_I = 16\text{V}$, $I_O = 500$ mA, $C_I = 0.33$ μF , $C_O = 0.1$ μF unless otherwise specified).

Symbol	Parameter	Test Conditions	Min.	Typ.	Max.	Unit
V_O	Output Voltage	$T_J = 25^\circ\text{C}$	9.6	10	10.4	V
V_O	Output Voltage	$I_O = 5$ mA to 1 A $P_O \leq 15\text{W}$ $V_I = 12.5$ to 26 V	9.5	10	10.5	V
ΔV_O (*)	Line Regulation	$V_I = 12.5$ to 26 V $T_J = 25^\circ\text{C}$			200	mV
		$V_I = 13.5$ to 19 V $T_J = 25^\circ\text{C}$			100	
ΔV_O (*)	Load Regulation	$I_O = 5$ mA to 1.5 A $T_J = 25^\circ\text{C}$			200	mV
		$I_O = 250$ to 750 mA $T_J = 25^\circ\text{C}$			100	
I_d	Quiescent Current	$T_J = 25^\circ\text{C}$			8	mA
ΔI_d	Quiescent Current Change	$I_O = 5$ mA to 1 A			0.5	mA
		$V_I = 12.5$ to 26 V			1	
$\Delta V_O/\Delta T$	Output Voltage Drift	$I_O = 5$ mA		-1		mV/ $^\circ\text{C}$
eN	Output Noise Voltage	B = 10Hz to 100KHz $T_J = 25^\circ\text{C}$		70		$\mu\text{V}/V_O$
SVR	Supply Voltage Rejection	$V_I = 13$ to 23 V $f = 120\text{Hz}$	55			dB
V_d	Dropout Voltage	$I_O = 1$ A $T_J = 25^\circ\text{C}$		2		V
R_O	Output Resistance	$f = 1$ KHz		17		m Ω
I_{sc}	Short Circuit Current	$V_I = 35$ V $T_J = 25^\circ\text{C}$		0.40		A
I_{scp}	Short Circuit Peak Current	$T_J = 25^\circ\text{C}$		2.2		A

(*) Load and line regulation are specified at constant junction temperature. Changes in V_O due to heating effects must be taken into account separately. Pulse testing with low duty cycle is used.

Table 19: Electrical Characteristics Of L7812C (refer to the test circuits, $T_J = 0$ to 125°C , $V_I = 19\text{V}$, $I_O = 500$ mA, $C_I = 0.33$ μF , $C_O = 0.1$ μF unless otherwise specified).

Symbol	Parameter	Test Conditions	Min.	Typ.	Max.	Unit
V_O	Output Voltage	$T_J = 25^\circ\text{C}$	11.5	12	12.5	V
V_O	Output Voltage	$I_O = 5$ mA to 1 A $P_O \leq 15\text{W}$ $V_I = 14.5$ to 27 V	11.4	12	12.6	V
ΔV_O (*)	Line Regulation	$V_I = 14.5$ to 30 V $T_J = 25^\circ\text{C}$			240	mV
		$V_I = 16$ to 22 V $T_J = 25^\circ\text{C}$			120	
ΔV_O (*)	Load Regulation	$I_O = 5$ mA to 1.5 A $T_J = 25^\circ\text{C}$			240	mV
		$I_O = 250$ to 750 mA $T_J = 25^\circ\text{C}$			120	
I_d	Quiescent Current	$T_J = 25^\circ\text{C}$			8	mA
ΔI_d	Quiescent Current Change	$I_O = 5$ mA to 1 A			0.5	mA
		$V_I = 14.5$ to 30 V			1	
$\Delta V_O/\Delta T$	Output Voltage Drift	$I_O = 5$ mA		-1		mV/ $^\circ\text{C}$
eN	Output Noise Voltage	$B = 10\text{Hz}$ to 100KHz $T_J = 25^\circ\text{C}$		75		$\mu\text{V}/V_O$
SVR	Supply Voltage Rejection	$V_I = 15$ to 25 V $f = 120\text{Hz}$	55			dB
V_d	Dropout Voltage	$I_O = 1$ A $T_J = 25^\circ\text{C}$		2		V
R_O	Output Resistance	$f = 1$ KHz		18		m Ω
I_{sc}	Short Circuit Current	$V_I = 35$ V $T_J = 25^\circ\text{C}$		0.35		A
I_{scp}	Short Circuit Peak Current	$T_J = 25^\circ\text{C}$		2.2		A

(*) Load and line regulation are specified at constant junction temperature. Changes in V_O due to heating effects must be taken into account separately. Pulse testing with low duty cycle is used.

Table 20: Electrical Characteristics Of L7815C (refer to the test circuits, $T_J = 0$ to 125°C , $V_I = 23\text{V}$, $I_O = 500$ mA, $C_I = 0.33$ μF , $C_O = 0.1$ μF unless otherwise specified).

Symbol	Parameter	Test Conditions	Min.	Typ.	Max.	Unit
V_O	Output Voltage	$T_J = 25^\circ\text{C}$	14.5	15	15.6	V
V_O	Output Voltage	$I_O = 5$ mA to 1 A $P_O \leq 15\text{W}$ $V_I = 17.5$ to 30 V	14.25	15	15.75	V
ΔV_O (*)	Line Regulation	$V_I = 17.5$ to 30 V $T_J = 25^\circ\text{C}$			300	mV
		$V_I = 20$ to 26 V $T_J = 25^\circ\text{C}$			150	
ΔV_O (*)	Load Regulation	$I_O = 5$ mA to 1.5 A $T_J = 25^\circ\text{C}$			300	mV
		$I_O = 250$ to 750 mA $T_J = 25^\circ\text{C}$			150	
I_d	Quiescent Current	$T_J = 25^\circ\text{C}$			8	mA
ΔI_d	Quiescent Current Change	$I_O = 5$ mA to 1 A			0.5	mA
		$V_I = 17.5$ to 30 V			1	
$\Delta V_O/\Delta T$	Output Voltage Drift	$I_O = 5$ mA		-1		mV/ $^\circ\text{C}$
eN	Output Noise Voltage	$B = 10\text{Hz}$ to 100KHz $T_J = 25^\circ\text{C}$		90		$\mu\text{V}/V_O$
SVR	Supply Voltage Rejection	$V_I = 18.5$ to 28.5 V $f = 120\text{Hz}$	54			dB
V_d	Dropout Voltage	$I_O = 1$ A $T_J = 25^\circ\text{C}$		2		V
R_O	Output Resistance	$f = 1$ KHz		19		m Ω
I_{sc}	Short Circuit Current	$V_I = 35$ V $T_J = 25^\circ\text{C}$		0.23		A
I_{scp}	Short Circuit Peak Current	$T_J = 25^\circ\text{C}$		2.2		A

(*) Load and line regulation are specified at constant junction temperature. Changes in V_O due to heating effects must be taken into account separately. Pulse testing with low duty cycle is used.

Table 21: Electrical Characteristics Of L7818C (refer to the test circuits, $T_J = 0$ to 125°C , $V_I = 26\text{V}$, $I_O = 500$ mA, $C_I = 0.33$ μF , $C_O = 0.1$ μF unless otherwise specified).

Symbol	Parameter	Test Conditions	Min.	Typ.	Max.	Unit
V_O	Output Voltage	$T_J = 25^\circ\text{C}$	17.3	18	18.7	V
V_O	Output Voltage	$I_O = 5$ mA to 1 A $P_O \leq 15\text{W}$ $V_I = 21$ to 33 V	17.1	18	18.9	V
ΔV_O (*)	Line Regulation	$V_I = 21$ to 33 V $T_J = 25^\circ\text{C}$			360	mV
		$V_I = 24$ to 30 V $T_J = 25^\circ\text{C}$			180	
ΔV_O (*)	Load Regulation	$I_O = 5$ mA to 1.5 A $T_J = 25^\circ\text{C}$			360	mV
		$I_O = 250$ to 750 mA $T_J = 25^\circ\text{C}$			180	
I_d	Quiescent Current	$T_J = 25^\circ\text{C}$			8	mA
ΔI_d	Quiescent Current Change	$I_O = 5$ mA to 1 A			0.5	mA
		$V_I = 21$ to 33 V			1	
$\Delta V_O/\Delta T$	Output Voltage Drift	$I_O = 5$ mA		-1		mV/ $^\circ\text{C}$
eN	Output Noise Voltage	B = 10Hz to 100KHz $T_J = 25^\circ\text{C}$		110		$\mu\text{V}/V_O$
SVR	Supply Voltage Rejection	$V_I = 22$ to 32 V $f = 120\text{Hz}$	53			dB
V_d	Dropout Voltage	$I_O = 1$ A $T_J = 25^\circ\text{C}$		2		V
R_O	Output Resistance	$f = 1$ KHz		22		m Ω
I_{sc}	Short Circuit Current	$V_I = 35$ V $T_J = 25^\circ\text{C}$		0.20		A
I_{scp}	Short Circuit Peak Current	$T_J = 25^\circ\text{C}$		2.1		A

(*) Load and line regulation are specified at constant junction temperature. Changes in V_O due to heating effects must be taken into account separately. Pulse testing with low duty cycle is used.

Table 22: Electrical Characteristics Of L7820C (refer to the test circuits, $T_J = 0$ to 125°C , $V_I = 28\text{V}$, $I_O = 500$ mA, $C_I = 0.33$ μF , $C_O = 0.1$ μF unless otherwise specified).

Symbol	Parameter	Test Conditions	Min.	Typ.	Max.	Unit
V_O	Output Voltage	$T_J = 25^\circ\text{C}$	19.2	20	20.8	V
V_O	Output Voltage	$I_O = 5$ mA to 1 A $P_O \leq 15\text{W}$ $V_I = 23$ to 35 V	19	20	21	V
ΔV_O (*)	Line Regulation	$V_I = 22.5$ to 35 V $T_J = 25^\circ\text{C}$			400	mV
		$V_I = 26$ to 32 V $T_J = 25^\circ\text{C}$			200	
ΔV_O (*)	Load Regulation	$I_O = 5$ mA to 1.5 A $T_J = 25^\circ\text{C}$			400	mV
		$I_O = 250$ to 750 mA $T_J = 25^\circ\text{C}$			200	
I_d	Quiescent Current	$T_J = 25^\circ\text{C}$			8	mA
ΔI_d	Quiescent Current Change	$I_O = 5$ mA to 1 A			0.5	mA
		$V_I = 23$ to 35 V			1	
$\Delta V_O/\Delta T$	Output Voltage Drift	$I_O = 5$ mA		-1		mV/ $^\circ\text{C}$
eN	Output Noise Voltage	B = 10Hz to 100KHz $T_J = 25^\circ\text{C}$		150		$\mu\text{V}/V_O$
SVR	Supply Voltage Rejection	$V_I = 24$ to 35 V $f = 120\text{Hz}$	52			dB
V_d	Dropout Voltage	$I_O = 1$ A $T_J = 25^\circ\text{C}$		2		V
R_O	Output Resistance	$f = 1$ KHz		24		m Ω
I_{sc}	Short Circuit Current	$V_I = 35$ V $T_J = 25^\circ\text{C}$		0.18		A
I_{scp}	Short Circuit Peak Current	$T_J = 25^\circ\text{C}$		2.1		A

(*) Load and line regulation are specified at constant junction temperature. Changes in V_O due to heating effects must be taken into account separately. Pulse testing with low duty cycle is used.

Table 23: Electrical Characteristics Of L7824C (refer to the test circuits, $T_J = 0$ to 125°C , $V_I = 33\text{V}$, $I_O = 500$ mA, $C_I = 0.33$ μF , $C_O = 0.1$ μF unless otherwise specified).

Symbol	Parameter	Test Conditions	Min.	Typ.	Max.	Unit
V_O	Output Voltage	$T_J = 25^\circ\text{C}$	23	24	25	V
V_O	Output Voltage	$I_O = 5$ mA to 1 A $P_O \leq 15\text{W}$ $V_I = 27$ to 38 V	22.8	24	25.2	V
$\Delta V_O(*)$	Line Regulation	$V_I = 27$ to 38 V $T_J = 25^\circ\text{C}$			480	mV
		$V_I = 30$ to 36 V $T_J = 25^\circ\text{C}$			240	
$\Delta V_O(*)$	Load Regulation	$I_O = 5$ mA to 1.5 A $T_J = 25^\circ\text{C}$			480	mV
		$I_O = 250$ to 750 mA $T_J = 25^\circ\text{C}$			240	
I_d	Quiescent Current	$T_J = 25^\circ\text{C}$			8	mA
ΔI_d	Quiescent Current Change	$I_O = 5$ mA to 1 A			0.5	mA
		$V_I = 27$ to 38 V			1	
$\Delta V_O/\Delta T$	Output Voltage Drift	$I_O = 5$ mA		-1.5		mV/ $^\circ\text{C}$
eN	Output Noise Voltage	B = 10Hz to 100KHz $T_J = 25^\circ\text{C}$		170		$\mu\text{V}/V_O$
SVR	Supply Voltage Rejection	$V_I = 28$ to 38 V $f = 120\text{Hz}$	50			dB
V_d	Dropout Voltage	$I_O = 1$ A $T_J = 25^\circ\text{C}$		2		V
R_O	Output Resistance	$f = 1$ KHz		28		m Ω
I_{sc}	Short Circuit Current	$V_I = 35$ V $T_J = 25^\circ\text{C}$		0.15		A
I_{scp}	Short Circuit Peak Current	$T_J = 25^\circ\text{C}$		2.1		A

(*) Load and line regulation are specified at constant junction temperature. Changes in V_O due to heating effects must be taken into account separately. Pulse testing with low duty cycle is used.

Figure 8: Dropout Voltage vs Junction Temperature

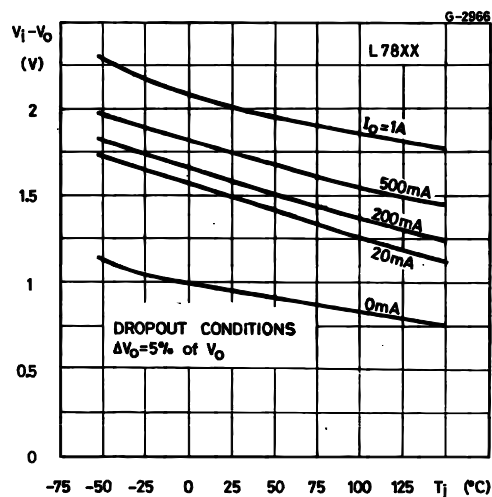

Figure 9: Peak Output Current vs Input/output Differential Voltage

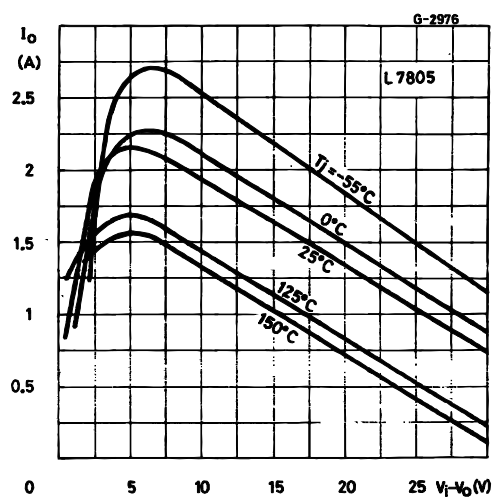

Figure 10: Supply Voltage Rejection vs Frequency

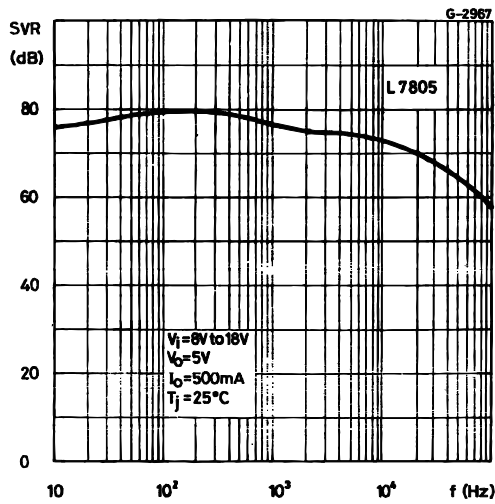

Figure 13: Quiescent Current vs Junction Temperature

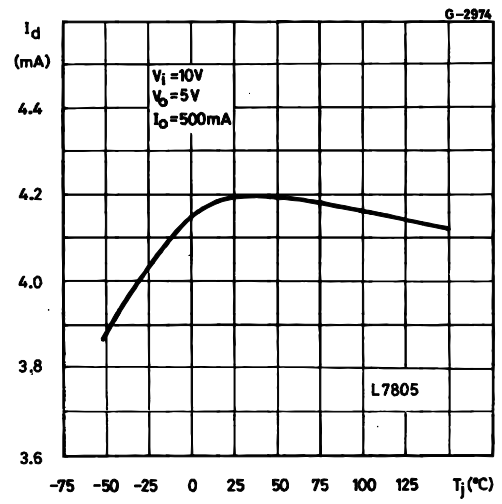

Figure 11: Output Voltage vs Junction Temperature

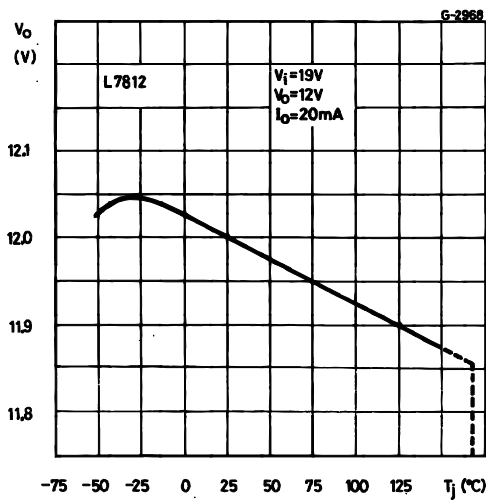

Figure 14: Load Transient Response

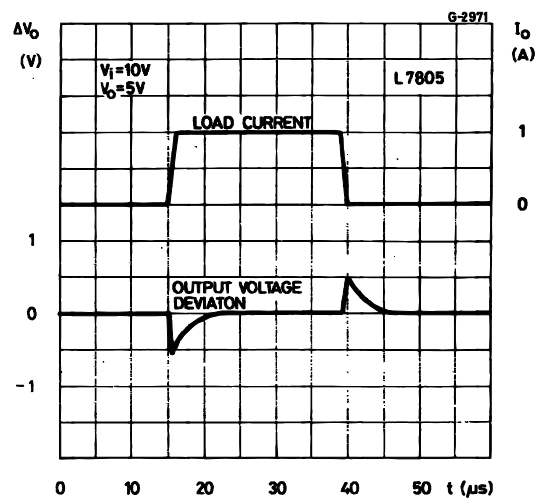

Figure 12: Output Impedance vs Frequency

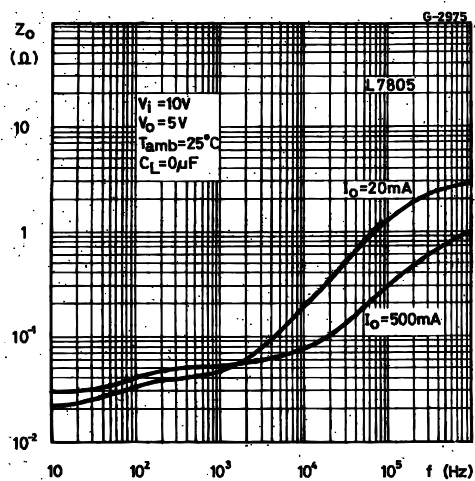

Figure 15: Line Transient Response

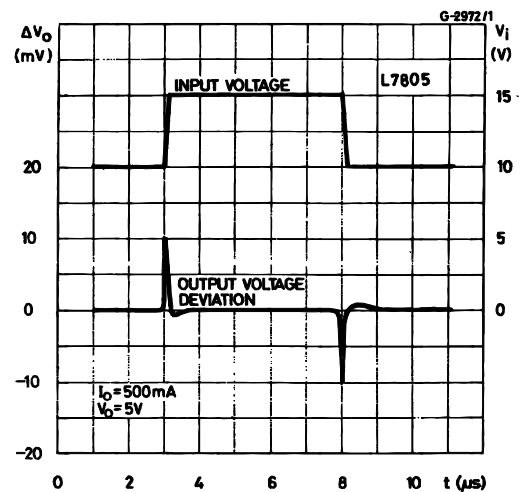

Figure 16: Quiescent Current vs Input Voltage

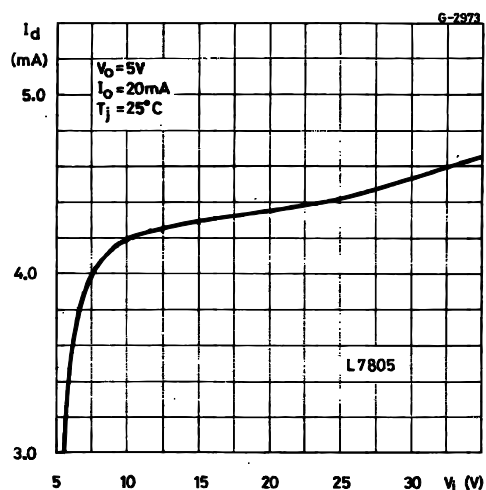
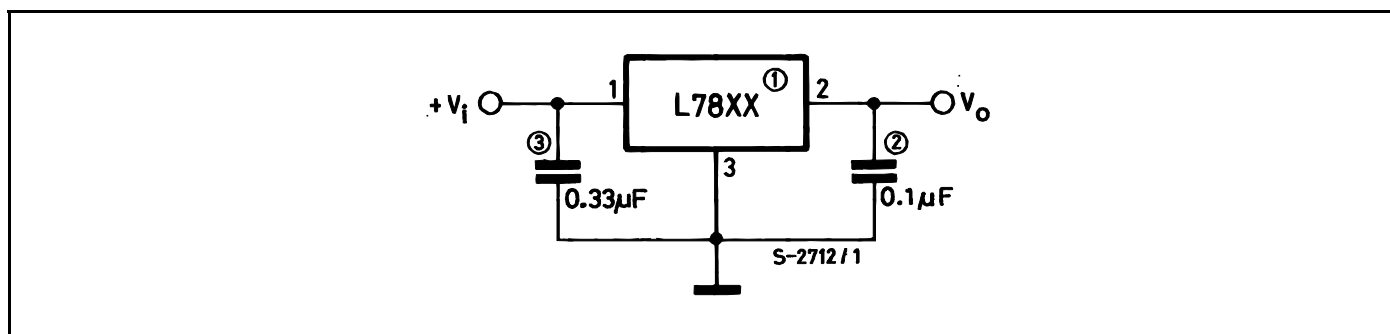

Figure 17: Fixed Output Regulator



NOTE:

1. To specify an output voltage, substitute voltage value for "XX".
2. Although no output capacitor is needed for stability, it does improve transient response.
3. Required if regulator is located an appreciable distance from power supply filter.

Figure 18: Current Regulator

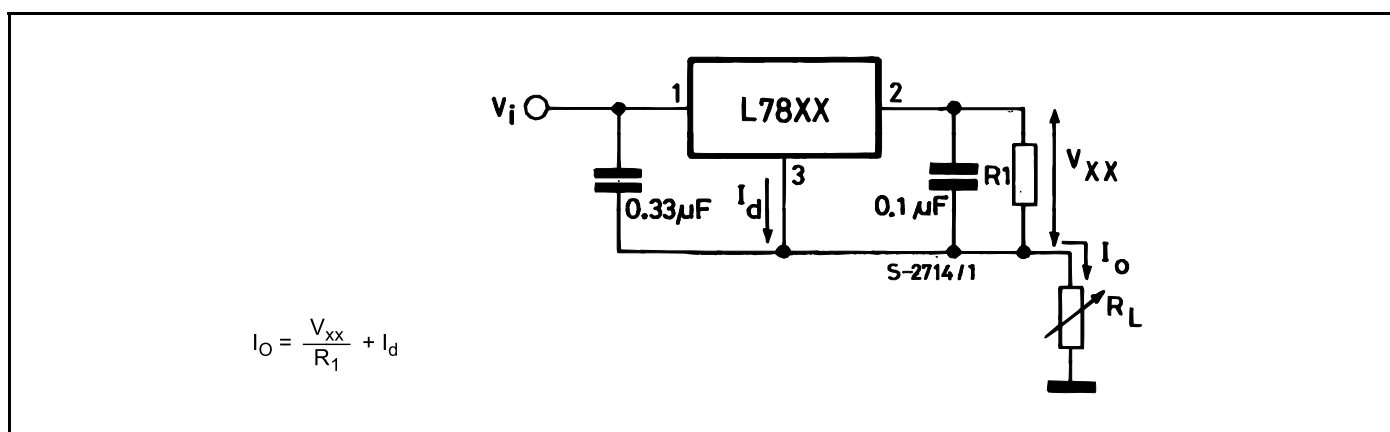

Figure 19: Circuit for Increasing Output Voltage

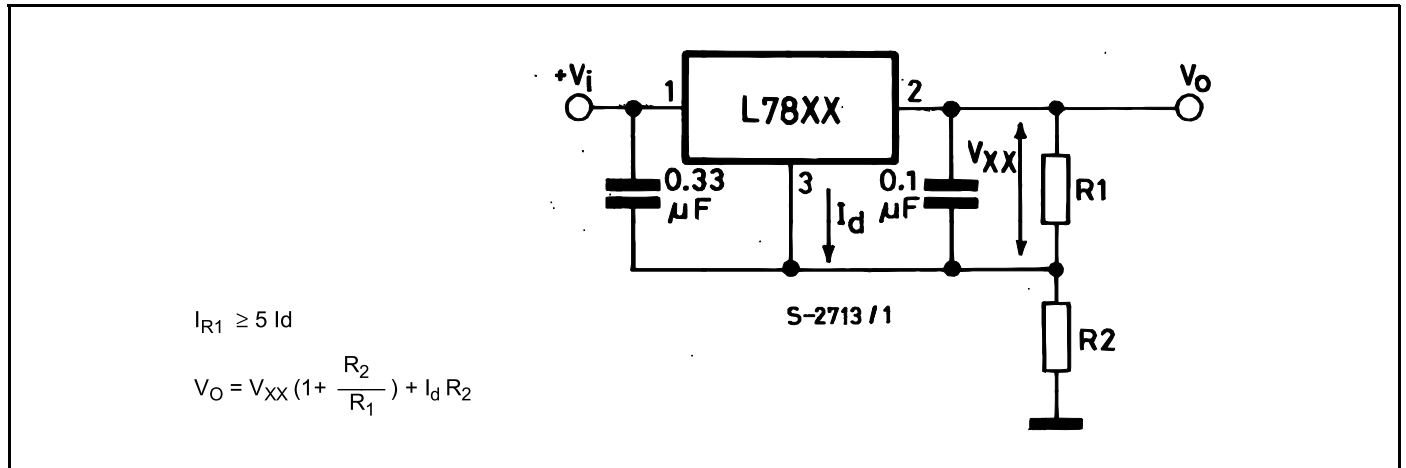

Figure 20: Adjustable Output Regulator (7 to 30V)

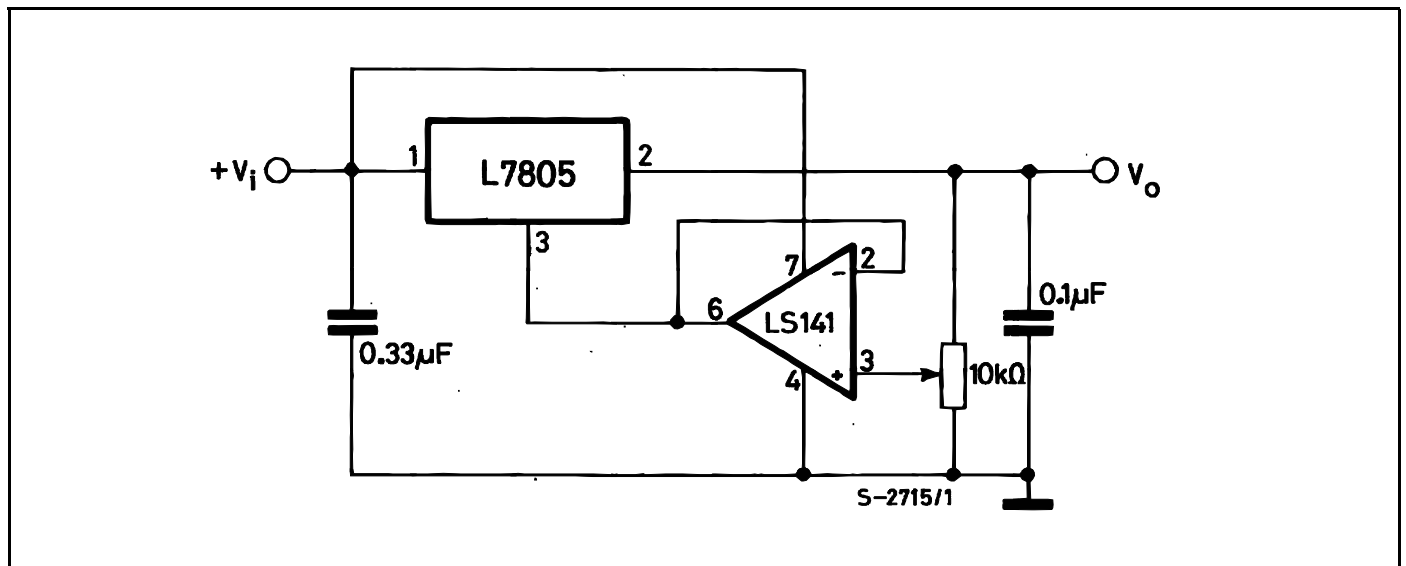

Figure 21: 0.5 to 10V Regulator

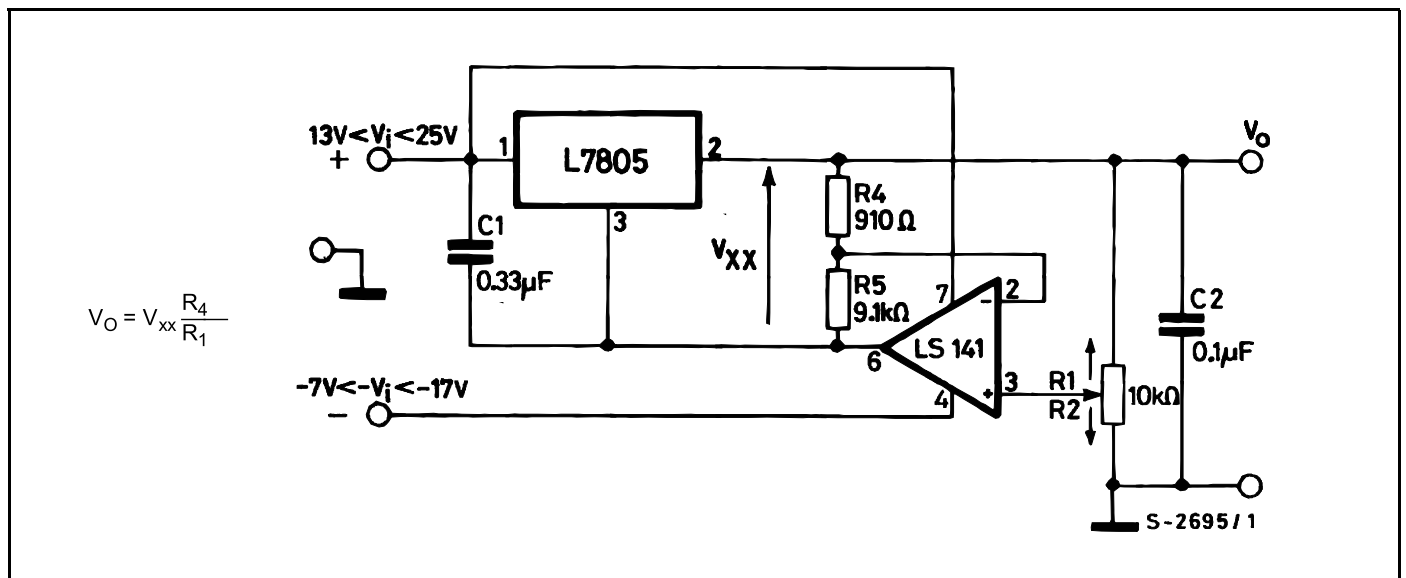

Figure 22: High Current Voltage Regulator

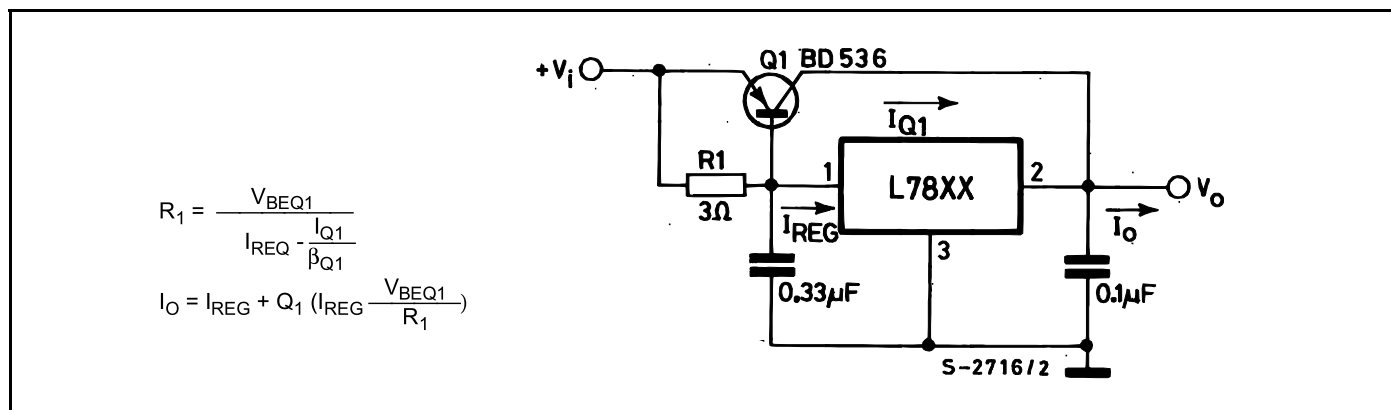

Figure 23: High Output Current with Short Circuit Protection

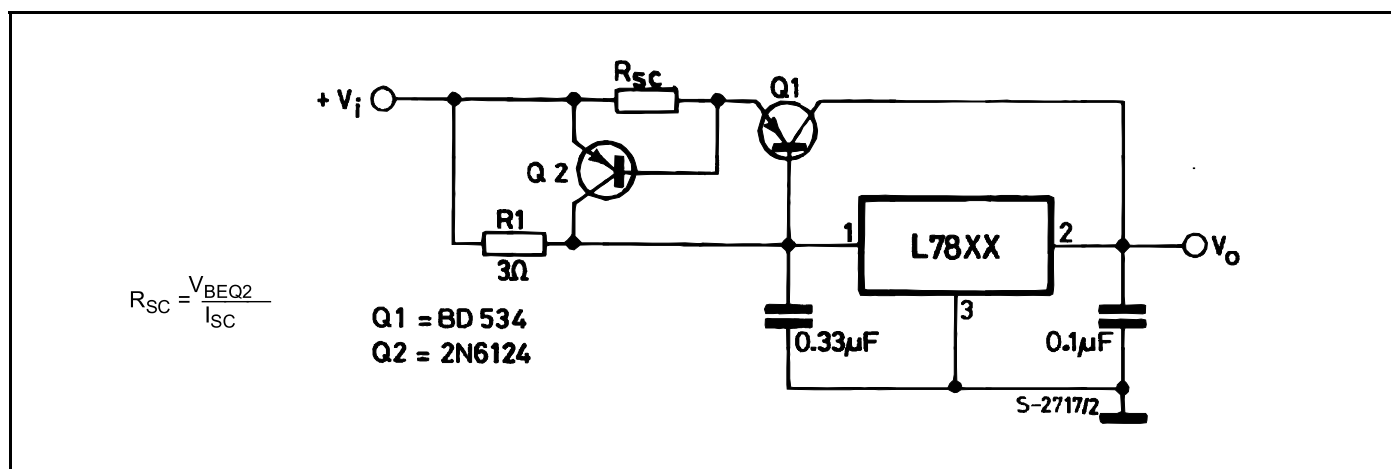

Figure 24: Tracking Voltage Regulator

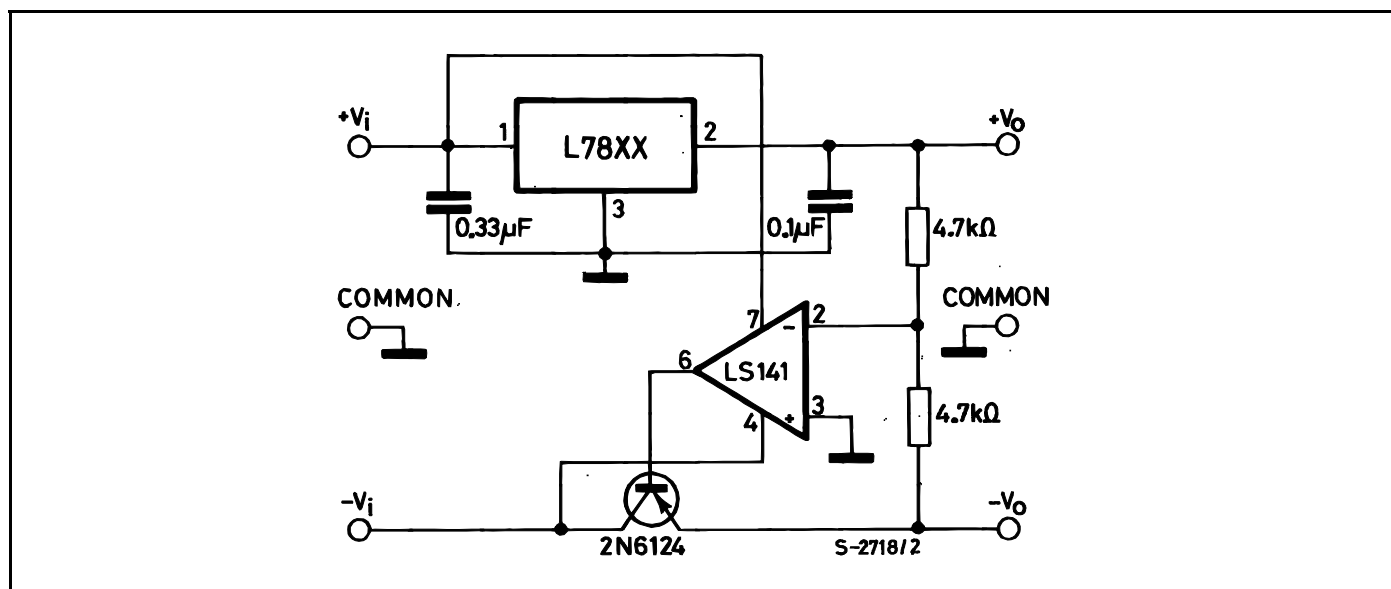

Figure 28: High Input Voltage Circuit

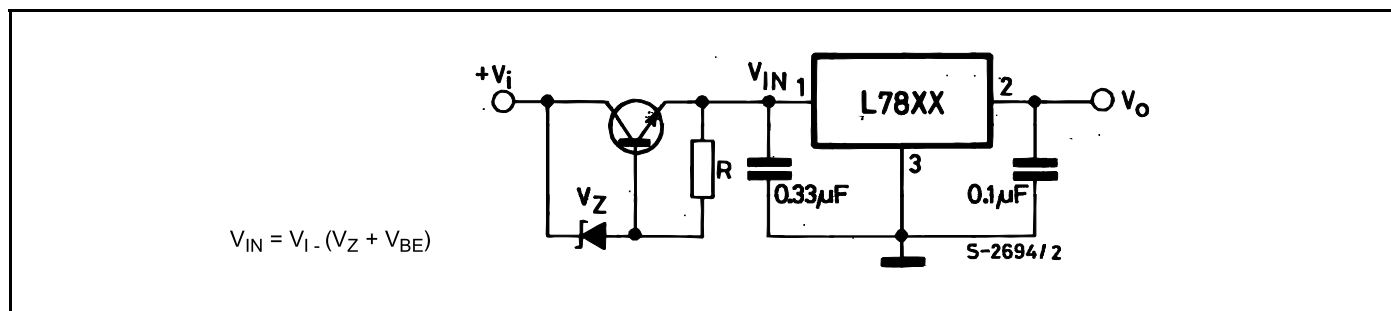

Figure 29: High Input Voltage Circuit

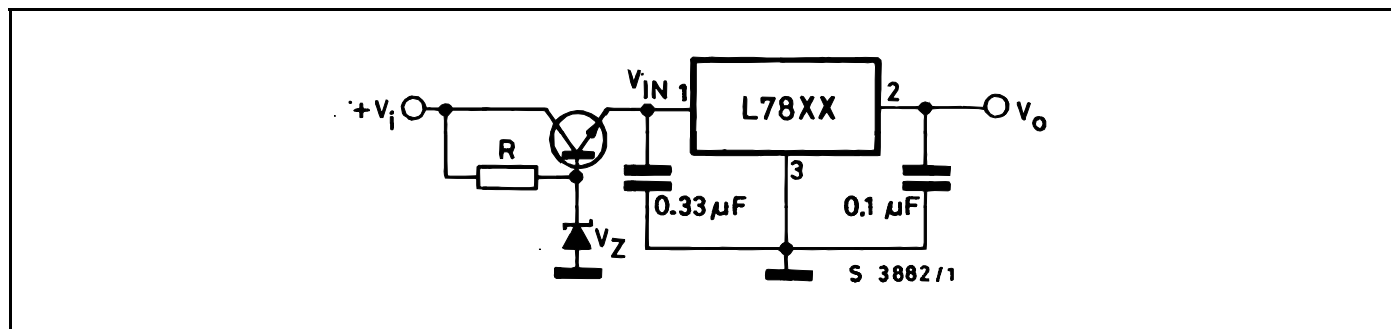

Figure 30: High Output Voltage Regulator

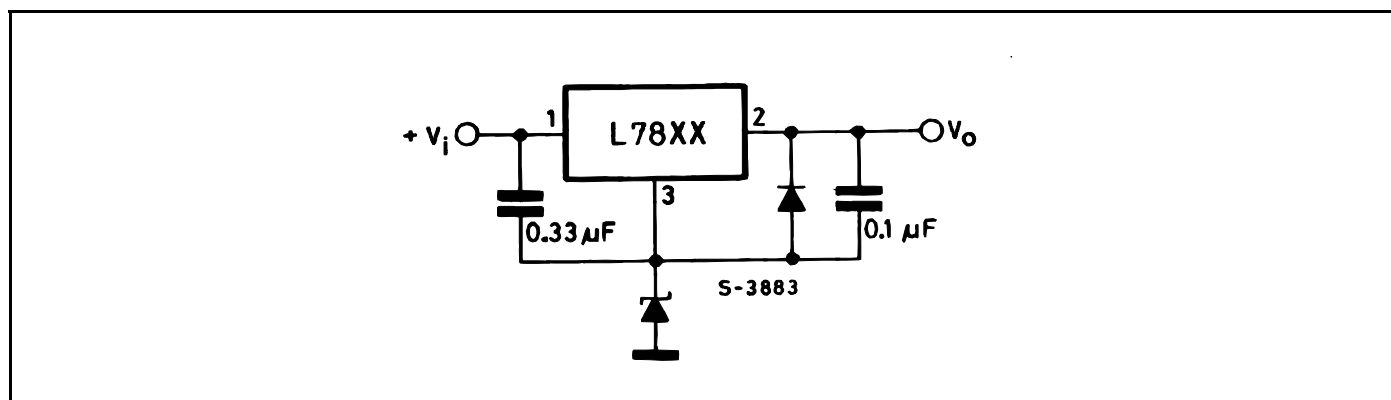

Figure 31: High Input and Output Voltage

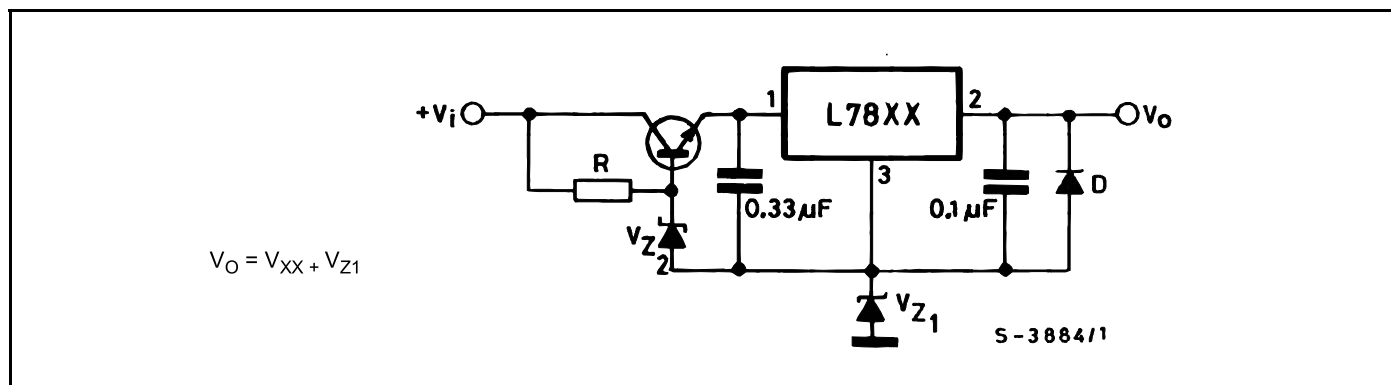

Figure 32: Reducing Power Dissipation with Dropping Resistor

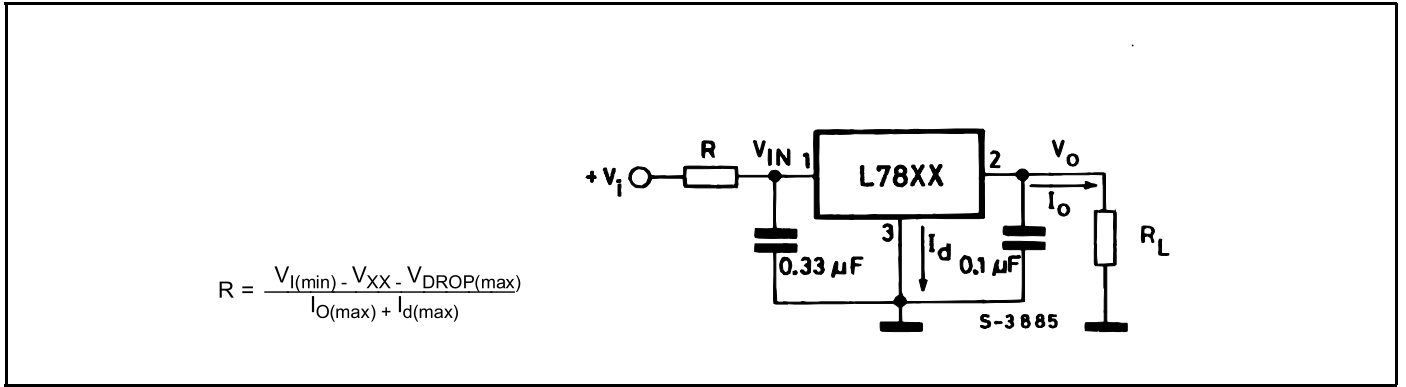

Figure 33: Remote Shutdown

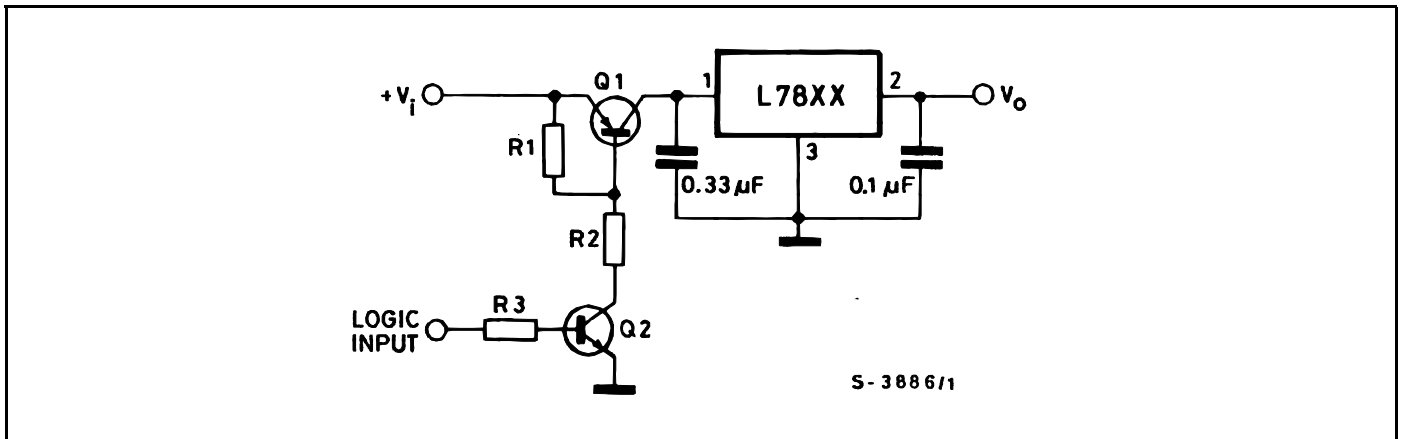
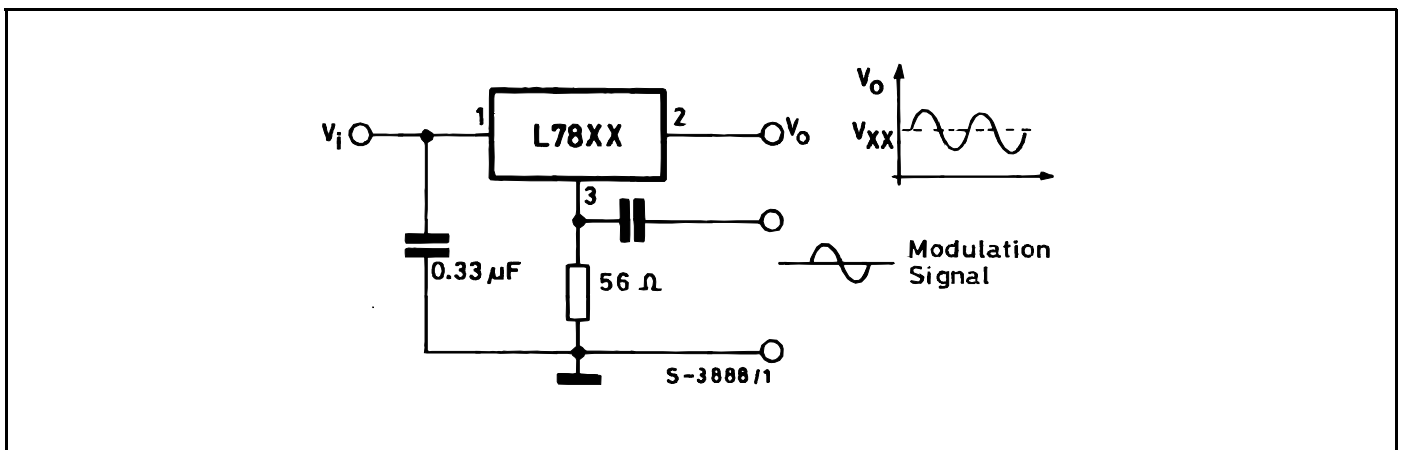
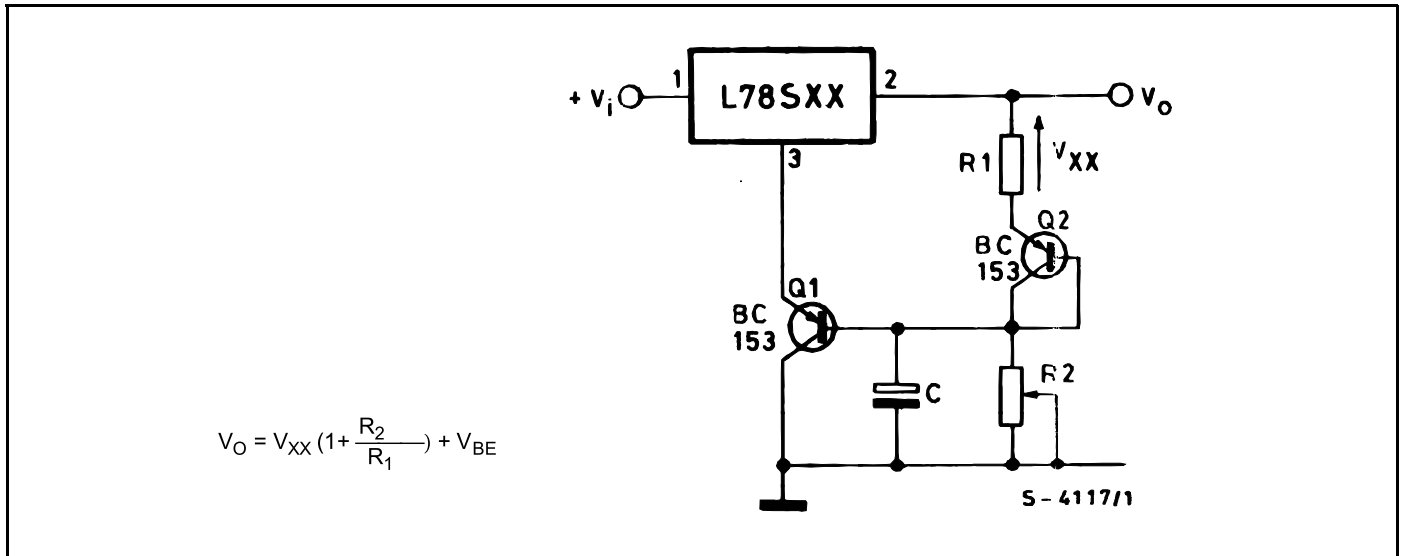

Figure 34: Power AM Modulator (unity voltage gain, $I_O \leq 0.5$)



NOTE: The circuit performs well up to 100 KHz.

Figure 35: Adjustable Output Voltage with Temperature Compensation



NOTE: Q₂ is connected as a diode in order to compensate the variation of the Q₁ V_{BE} with the temperature. C allows a slow rise time of the V_O.

Figure 36: Light Controllers (V_{Omin} = V_{XX} + V_{BE})

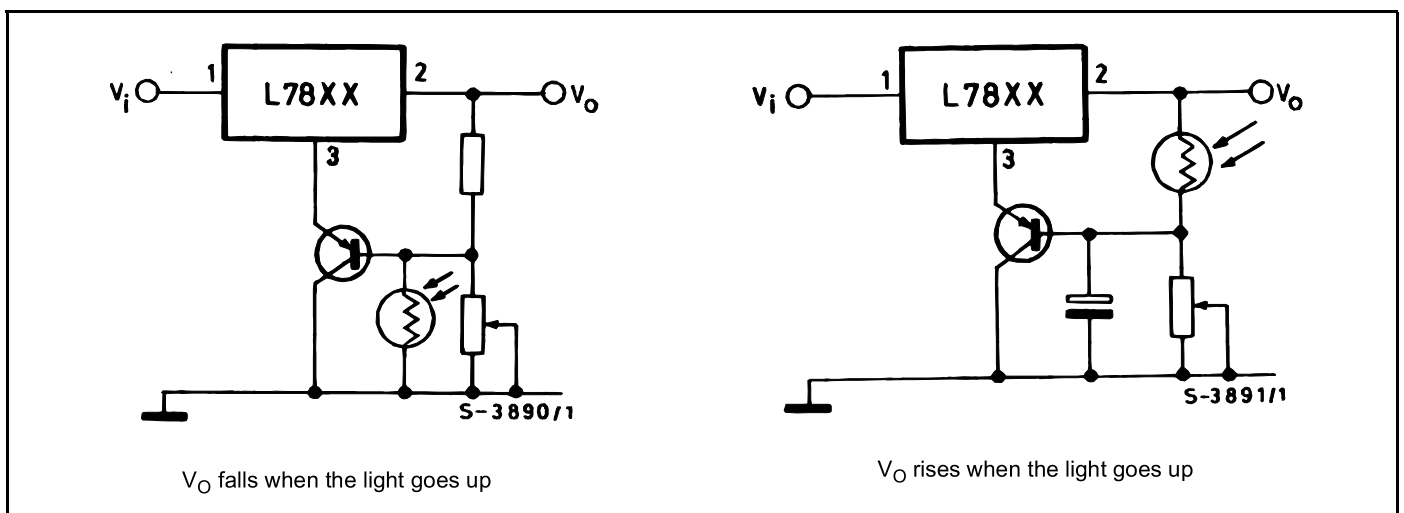
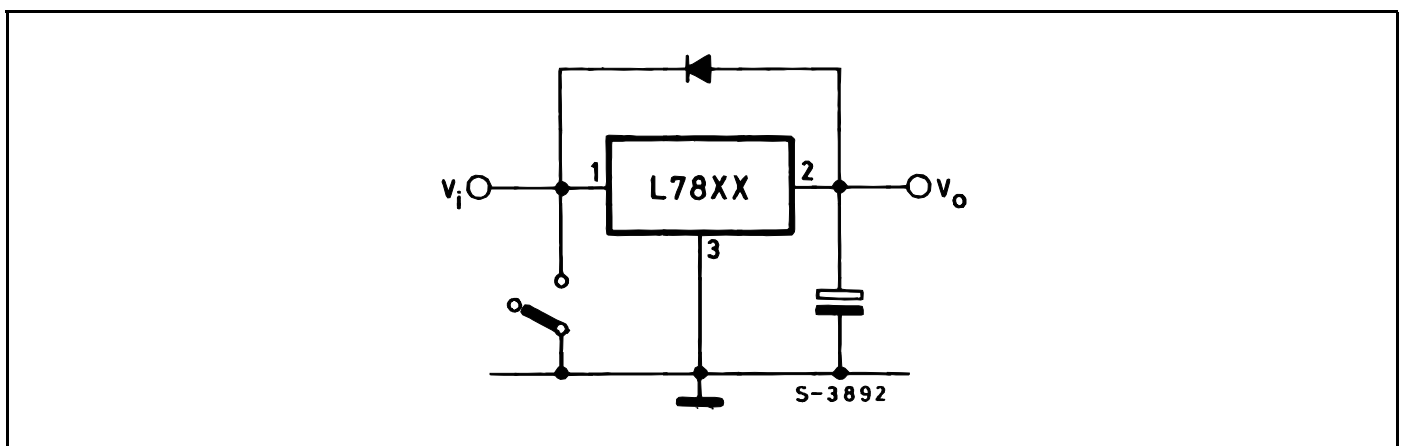

Figure 37: Protection against Input Short-Circuit with High Capacitance Loads



Application with high capacitance loads and an output voltage greater than 6 volts need an external diode (see fig. 33) to protect the device against input short circuit. In this case the input voltage falls rapidly while the output voltage decrease slowly. The capacitance discharges by means of the Base-Emitter junction of the series pass transistor in the regulator. If the energy is sufficiently high, the transistor may be destroyed. The external diode by-passes the current from the IC to ground.

TO-3 MECHANICAL DATA

DIM.	mm.			inch		
	MIN.	TYP	MAX.	MIN.	TYP.	MAX.
A		11.85			0.466	
B	0.96	1.05	1.10	0.037	0.041	0.043
C			1.70			0.066
D			8.7			0.342
E			20.0			0.787
G		10.9			0.429	
N		16.9			0.665	
P			26.2			1.031
R	3.88		4.09	0.152		0.161
U			39.5			1.555
V		30.10			1.185	

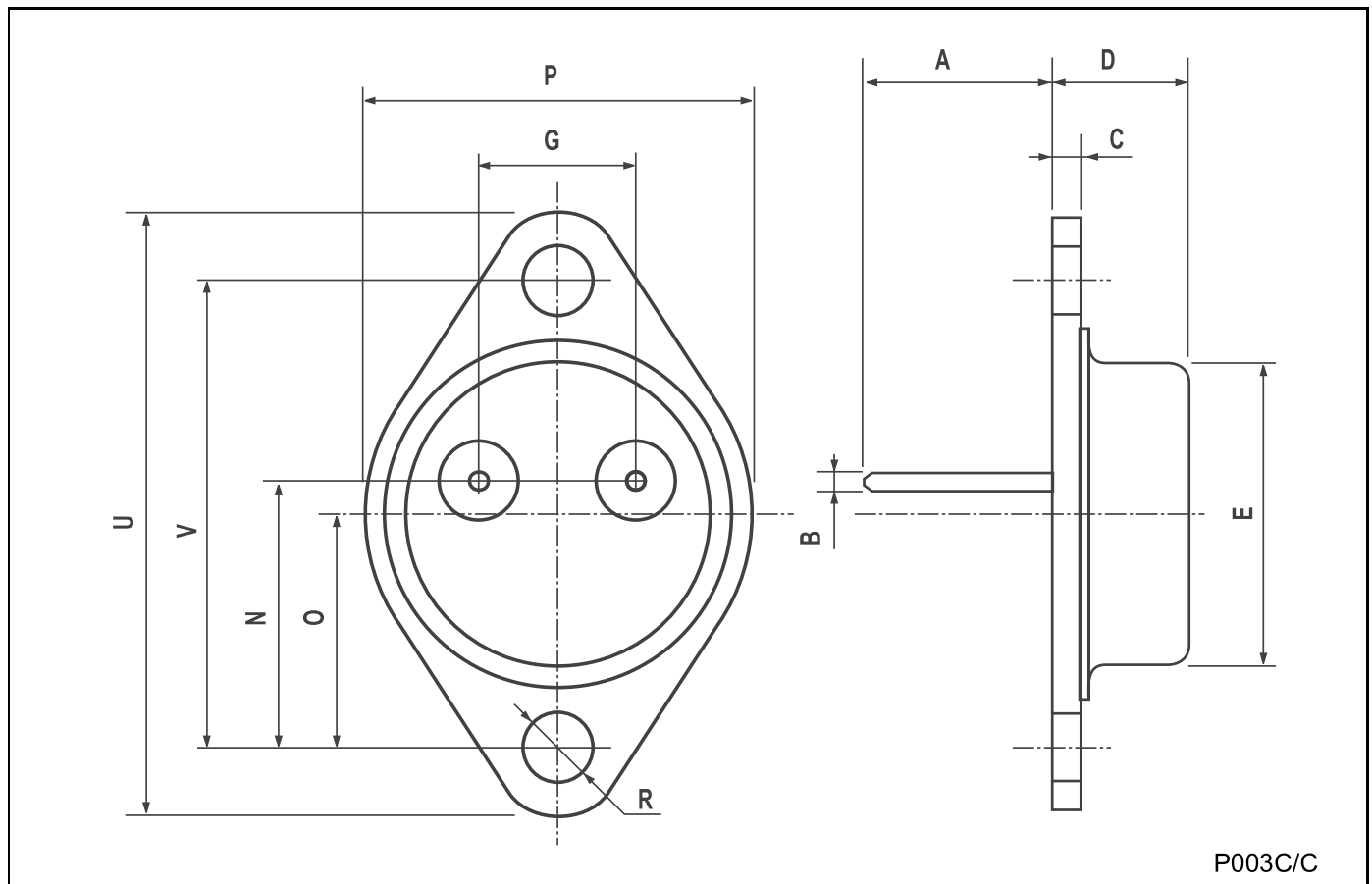

P003C/C

TO-220 (A TYPE) MECHANICAL DATA

DIM.	mm.			inch		
	MIN.	TYP	MAX.	MIN.	TYP.	MAX.
A	4.40		4.60	0.173		0.181
b	0.61		0.88	0.024		0.034
b1	1.15		1.70	0.045		0.067
c	0.49		0.70	0.019		0.027
D	15.25		15.75	0.600		0.620
E	10.0		10.40	0.393		0.409
e	2.4		2.7	0.094		0.106
e1	4.95		5.15	0.194		0.203
F	1.23		1.32	0.048		0.051
H1	6.2		6.6	0.244		0.260
J1	2.40		2.72	0.094		0.107
L	13.0		14.0	0.511		0.551
L1	3.5		3.93	0.137		0.154
L20		16.4			0.645	
L30		28.9			1.138	
ϕP	3.75		3.85	0.147		0.151
Q	2.65		2.95	0.104		0.116

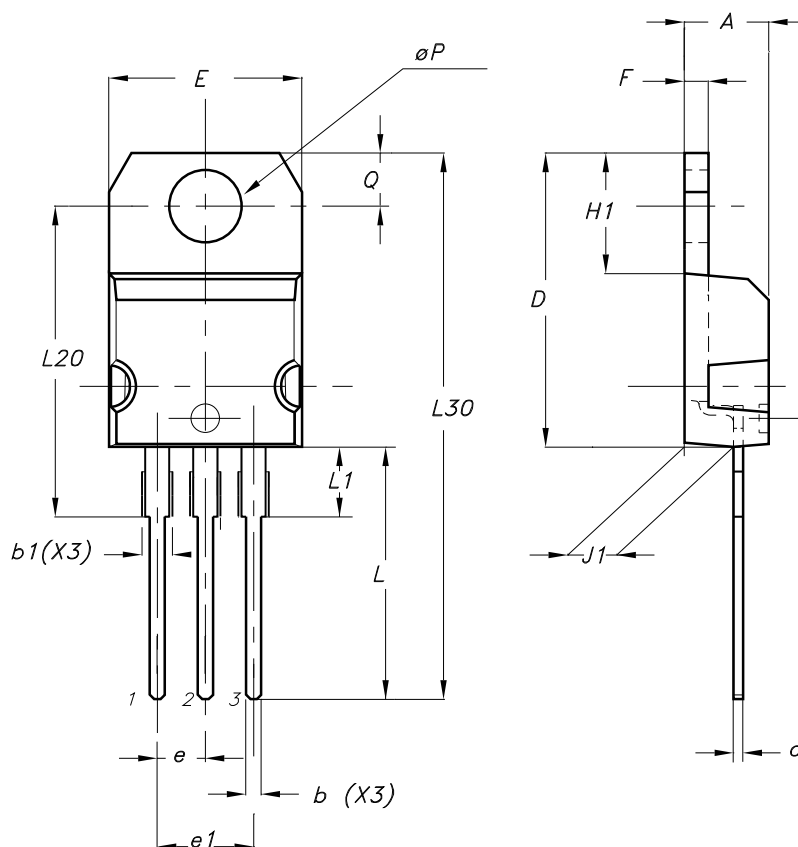

0015988/N

TO-220 (C TYPE) MECHANICAL DATA

DIM.	mm.			inch		
	MIN.	TYP	MAX.	MIN.	TYP.	MAX.
A	4.30		4.70	0.169		0.185
b	0.70		0.90	0.028		0.035
b1	1.42		1.62	0.056		0.064
c	0.45		0.60	0.018		0.024
D		15.70			0.618	
E	9.80		10.20	0.386		0.402
e		2.54			0.100	
e1		5.08			0.200	
F	1.25		1.39	0.049		0.055
H1		6.5			0.256	
J1	2.20		2.60	0.087		0.202
L	12.88		13.28	0.507		0.523
L1		3			0.118	
L20	15.70		16.1	0.618		0.634
L30		28.9			1.138	
ϕP	3.50		3.70	0.138		0.146
Q	2.70		2.90	0.106		0.114

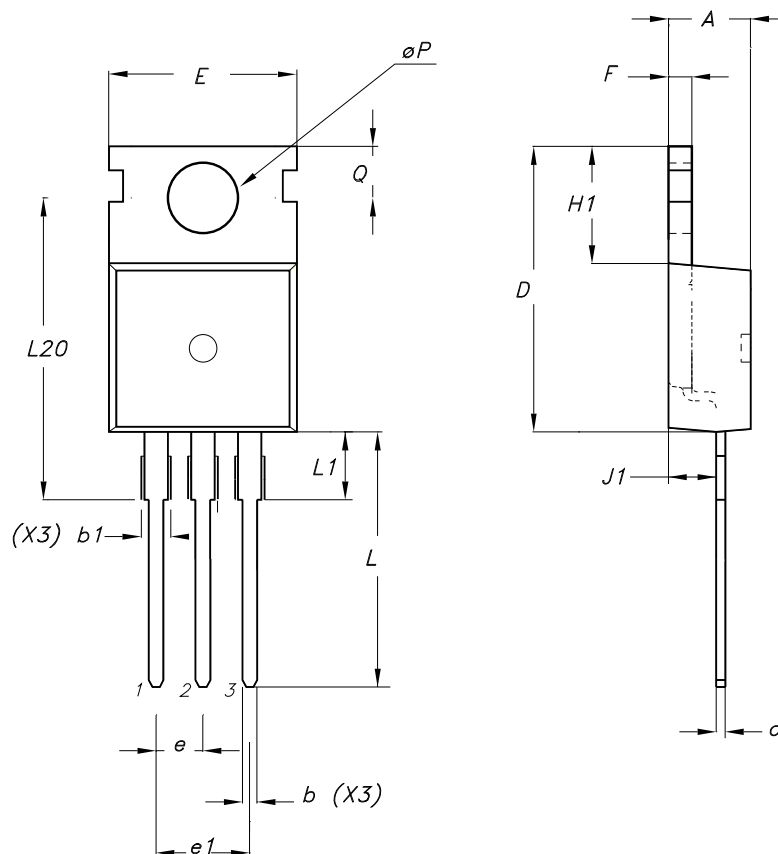

0015988/N

TO-220 (E TYPE) MECHANICAL DATA

DIM.	mm.			inch		
	MIN.	TYP	MAX.	MIN.	TYP.	MAX.
A	4.47		4.67	0.176		0.184
b	0.70		0.91	0.028		0.036
b1	1.17		1.37	0.046		0.054
c	0.31		0.53	0.012		0.021
D	14.60		15.70	0.575		0.618
E	9.96		10.36	0.392		0.408
e		2.54			0.100	
e1		5.08			0.200	
F	1.17		1.37	0.046		0.054
H1	6.1		6.8	0.240		0.268
J1	2.52		2.82	0.099		0.111
L	12.70		13.80	0.500		0.543
L1	3.20		3.96	0.126		0.156
L20	15.21		16.77	0.599		0.660
ϕP	3.73		3.94	0.147		0.155
Q	2.59		2.89	0.102		0.114

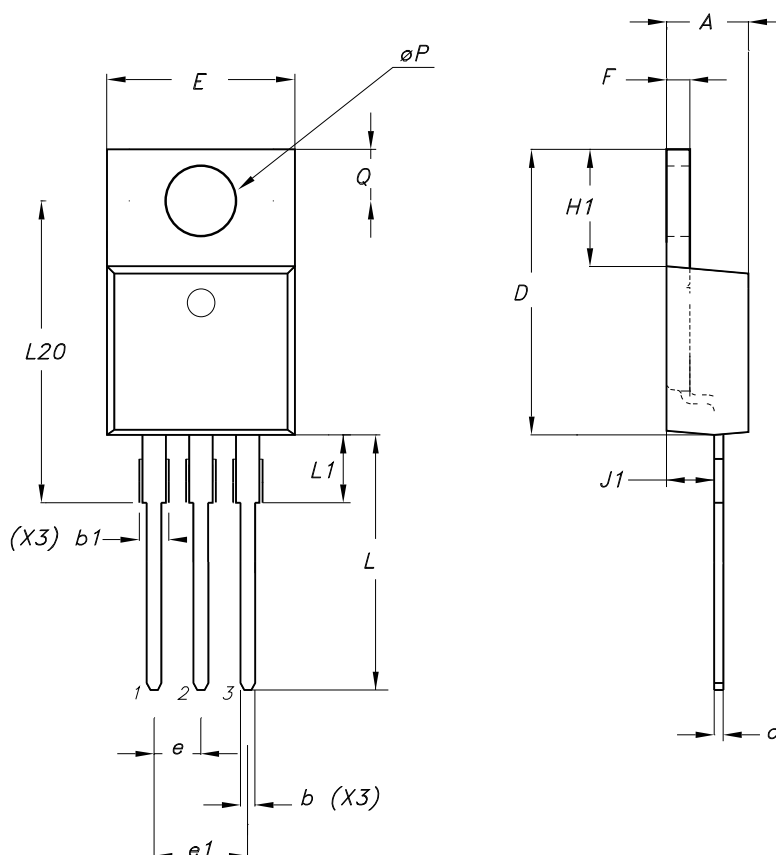

7655923/A

TO-220FM MECHANICAL DATA

DIM.	mm.			inch		
	MIN.	TYP	MAX.	MIN.	TYP.	MAX.
A	4.50		4.90	0.177		0.193
B	2.34		2.74	0.092		0.108
D	2.56		2.96	0.101		0.117
E	0.45	0.50	0.60	0.018	0.020	0.024
F	0.70		0.90	0.028		0.035
F1			1.47			0.058
G		5.08			0.200	
G1	2.34	2.54	2.74	0.092	0.100	0.108
H	9.96		10.36	0.392		0.408
L2		15.8			0.622	
L4	9.45		10.05	0.372		0.396
L6	15.67		16.07	0.617		0.633
L7	8.99		9.39	0.354		0.370
L8		3.30			0.130	
DIA.	3.08		3.28	0.121		0.129

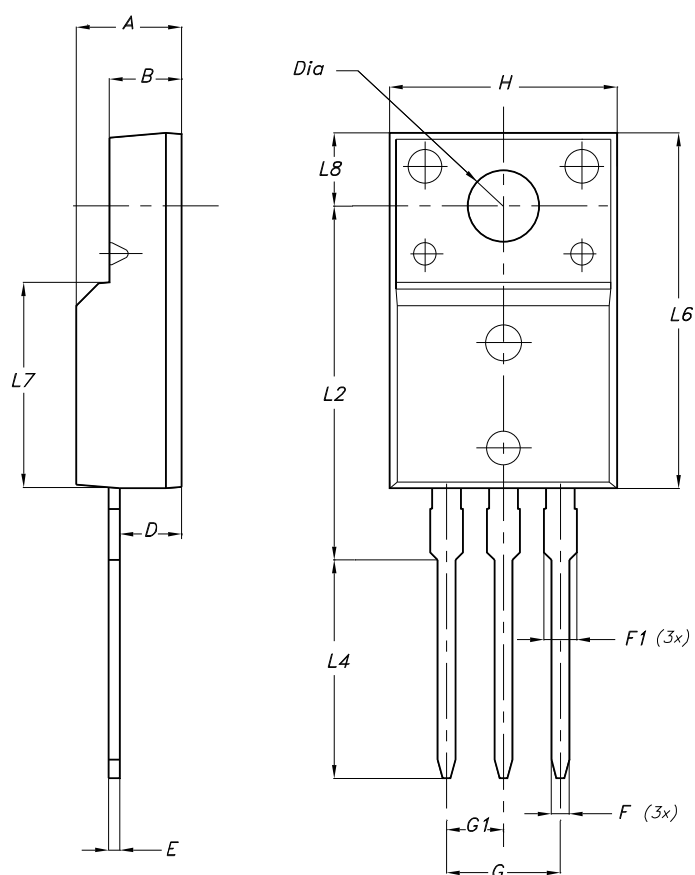

7012510C-H

D²PAK (A TYPE) MECHANICAL DATA

DIM.	mm.			inch		
	MIN.	TYP	MAX.	MIN.	TYP.	MAX.
A	4.4		4.6	0.173		0.181
A1	0.03		0.23	0.001		0.009
b	0.7		0.93	0.027		0.036
b2	1.14		1.7	0.044		0.067
c	0.45		0.6	0.017		0.023
c2	1.23		1.36	0.048		0.053
D	8.95		9.35	0.352		0.368
D1	8			0.315		
E	10		10.4	0.393		0.409
E1	8.5			0.335		
e		2.54			0.100	
e1	4.88		5.28	0.192		0.208
H	15		15.85	0.590		0.624
J1	2.49		2.69	0.098		0.106
L	2.29		2.79	0.090		0.110
L1	1.27		1.4	0.050		0.055
L2	1.3		1.75	0.051		0.069
R		0.4			0.016	
V2	0°		8°	0°		8°

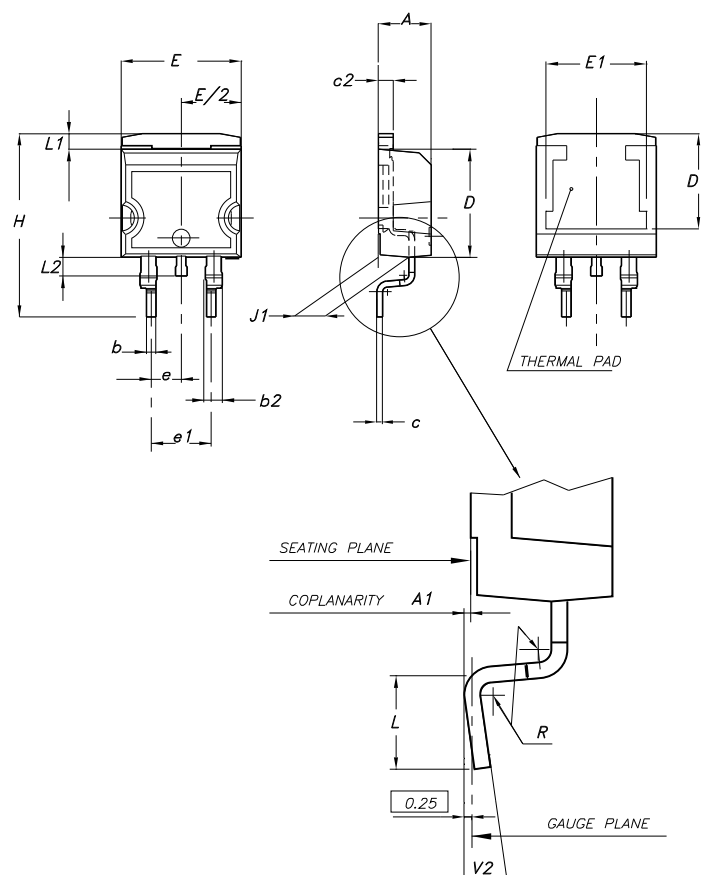

0079457/J

D²PAK (C TYPE) MECHANICAL DATA

DIM.	mm.			inch		
	MIN.	TYP	MAX.	MIN.	TYP.	MAX.
A	4.3		4.7	0.169		0.185
A1	0		0.20	0.000		0.008
b	0.70		0.90	0.028		0.035
b2	1.17		1.37	0.046		0.054
c	0.45	0.50	0.6	0.018	0.020	0.024
c2	1.25	1.30	1.40	0.049	0.051	0.055
D	9.0	9.2	9.4	0.354	0.362	0.370
D1	7.5			0.295		
E	9.8		10.2	0.386		0.402
E1	7.5			0.295		
e		2.54			0.100	
e1		5.08			0.200	
H	15	15.30	15.60	0.591	0.602	0.614
J1	2.20		2.60	0.087		0.102
L	1.79		2.79	0.070		0.110
L1	1.0		1.4	0.039		0.055
L2	1.2		1.6	0.047		0.063
R		0.3			0.012	
V2	0°		3°	0°		3°

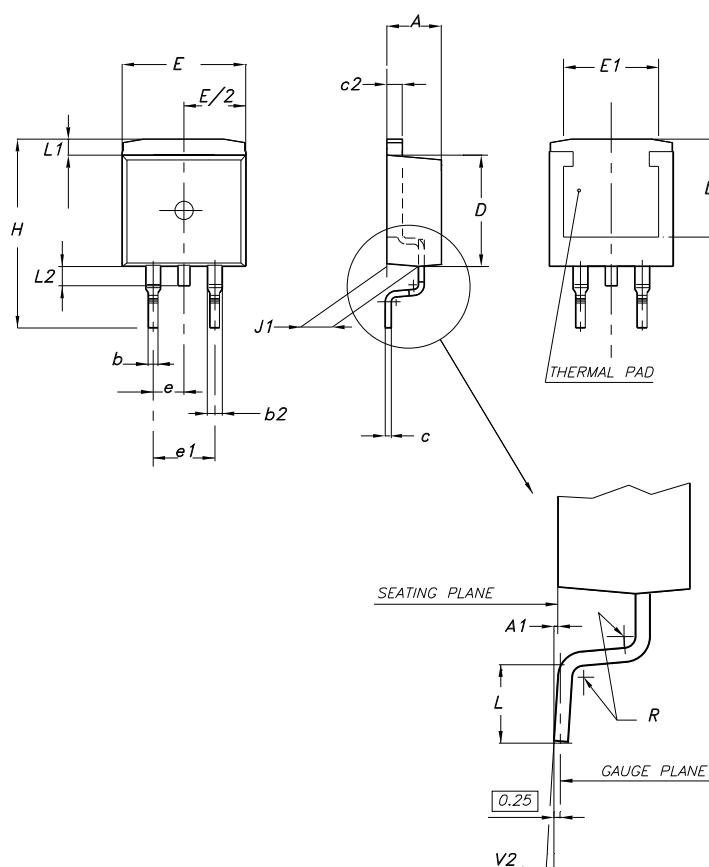

0079457/J

Tape & Reel D²PAK-P²PAK-D²PAK/A-P²PAK/A MECHANICAL DATA

DIM.	mm.			inch		
	MIN.	TYP	MAX.	MIN.	TYP.	MAX.
A			180			7.086
C	12.8	13.0	13.2	0.504	0.512	0.519
D	20.2			0.795		
N	60			2.362		
T			14.4			0.567
Ao	10.50	10.6	10.70	0.413	0.417	0.421
Bo	15.70	15.80	15.90	0.618	0.622	0.626
Ko	4.80	4.90	5.00	0.189	0.193	0.197
Po	3.9	4.0	4.1	0.153	0.157	0.161
P	11.9	12.0	12.1	0.468	0.472	0.476

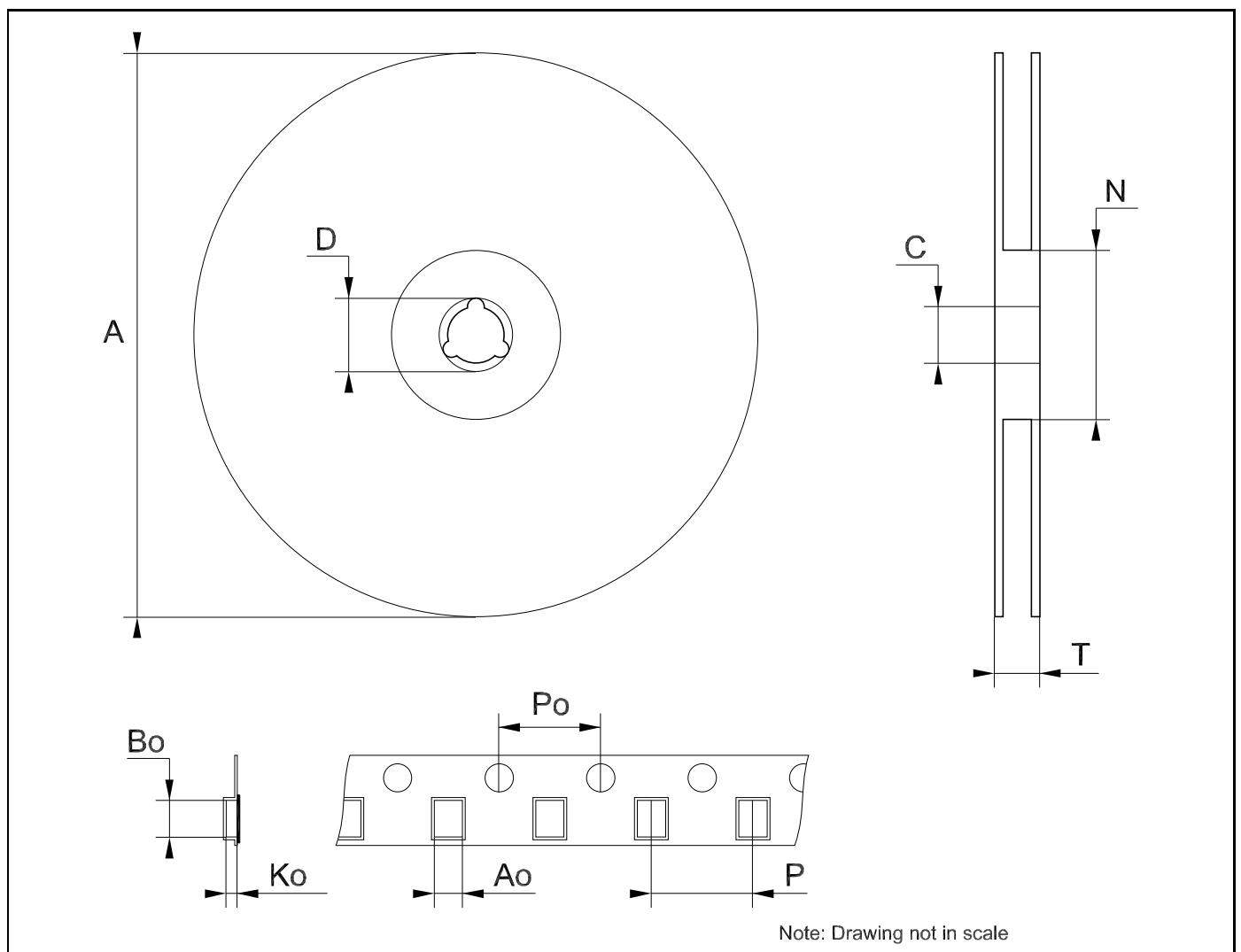

Table 24: Revision History

Date	Revision	Description of Changes
09-Nov-2004	12	Add New Part Number.

Information furnished is believed to be accurate and reliable. However, STMicroelectronics assumes no responsibility for the consequences of use of such information nor for any infringement of patents or other rights of third parties which may result from its use. No license is granted by implication or otherwise under any patent or patent rights of STMicroelectronics. Specifications mentioned in this publication are subject to change without notice. This publication supersedes and replaces all information previously supplied. STMicroelectronics products are not authorized for use as critical components in life support devices or systems without express written approval of STMicroelectronics.

The ST logo is a registered trademark of STMicroelectronics

All other names are the property of their respective owners

© 2004 STMicroelectronics - All Rights Reserved

STMicroelectronics group of companies

Australia - Belgium - Brazil - Canada - China - Czech Republic - Finland - France - Germany - Hong Kong - India - Israel - Italy - Japan -
Malaysia - Malta - Morocco - Singapore - Spain - Sweden - Switzerland - United Kingdom - United States of America

www.st.com