

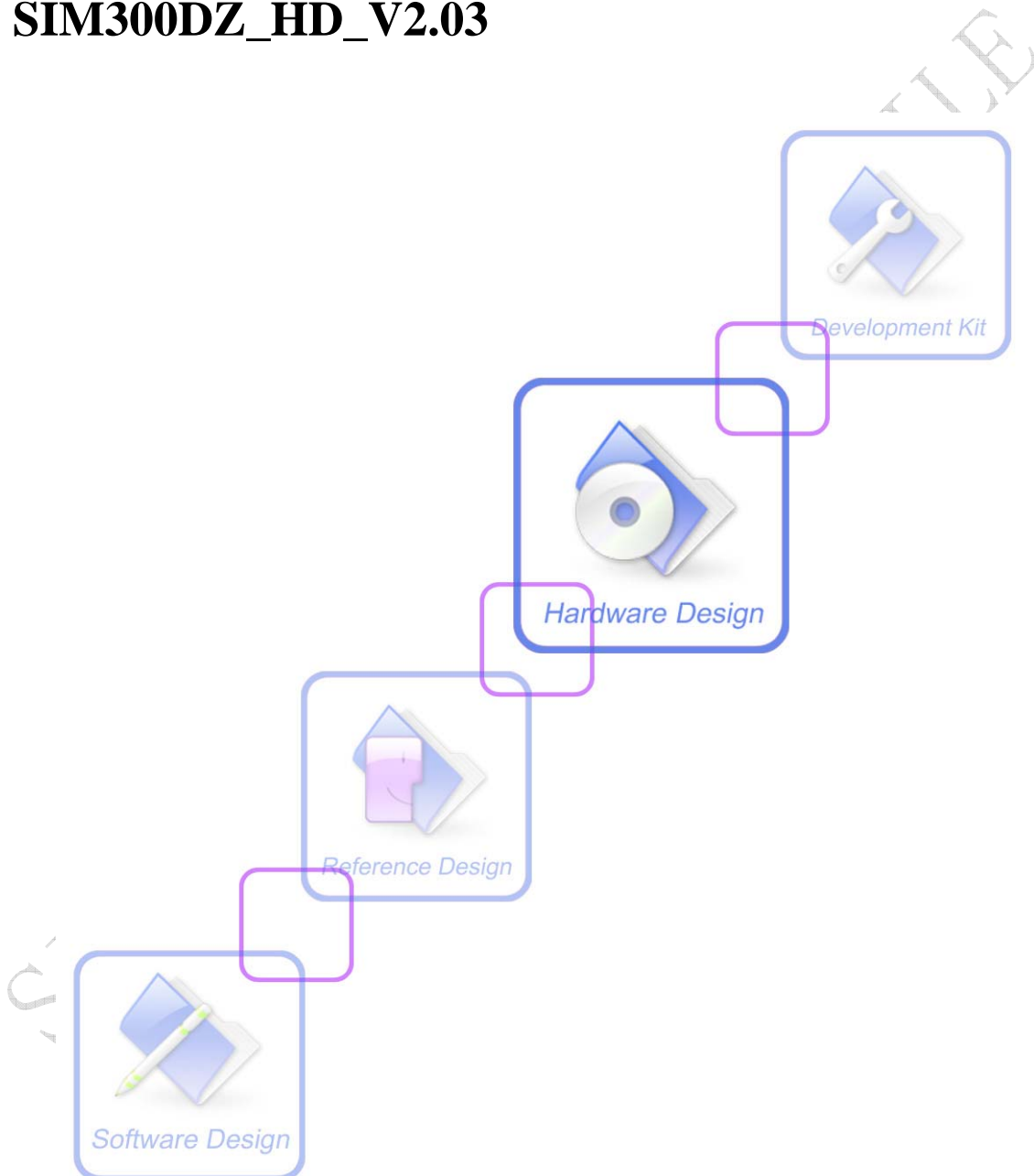

Hardware Design

SIM300DZ_HD_V2.03



Document Title:	SIM300DZ Hardware Design
Version:	2.03
Date:	2007-01-10
Status:	Release
Document Control ID:	SIM300DZ_HD_V2.03

General Notes

Simcom offers this information as a service to its customers, to support application and engineering efforts that use the products designed by Simcom. The information provided is based upon requirements specifically provided to Simcom by the customers. Simcom has not undertaken any independent search for additional relevant information, including any information that may be in the customer's possession. Furthermore, system validation of this product designed by Simcom within a larger electronic system remains the responsibility of the customer or the customer's system integrator. All specifications supplied herein are subject to change.

Copyright

This document contains proprietary technical information which is the property of SIMCOM Limited., copying of this document and giving it to others and the using or communication of the contents thereof, are forbidden without express authority. Offenders are liable to the payment of damages. All rights reserved in the event of grant of a patent or the registration of a utility model or design. All specification supplied herein are subject to change without notice at any time.

Copyright © SIMCOM Limited. 2007

Contents

Contents	3
Version history	7
1 Introduction	8
1.1 Related documents	8
1.2 Terms and abbreviations	9
2 Product concept	11
2.1 SIM300DZ key features at a glance	12
3 Application interface	14
3.1 SIM300DZ pin description	14
3.2 Operating modes	16
3.3 Power supply	18
3.3.1 Power supply pins	18
3.3.2 Minimizing power losses	19
3.3.3 Monitoring power supply	19
3.4 Power up / down scenarios	19
3.4.1 Turn on SIM300DZ	19
3.4.2 Turn off SIM300DZ	21
3.4.3 Restart SIM300DZ using the PWRKEY pin	24
3.5 Charging interface	24
3.5.1 Battery pack characteristics	25
3.5.2 Recommended battery pack	25
3.5.3 Implemented charging technique	26
3.5.4 Operating modes during charging	27
3.5.5 Charger requirements	28
3.6 Power saving	28
3.6.1 Minimum functionality mode	28
3.6.2 SLEEP mode (slow clocking mode)	29
3.6.3 Wake up SIM300DZ from SLEEP mode	29
3.7 Summary of state transitions (except SLEEP mode)	30
3.8 RTC backup	31
3.9 Serial interfaces	34
3.9.1 Function of Serial port and Debug port supporting	35
3.9.2 Software upgrade and serial Port	36
3.10 Audio interfaces	38
3.10.1 Speaker interface configuration	39
3.10.2 Microphone interfaces configuration	40
3.10.3 Earphone interface configuration	41
3.10.4 Referenced electronic characteristic	41
3.11 SIM interface	42
3.11.1 SIM card application	42

SIM300DZ Hardware Design

3.11.2 Design considerations for SIM card holder	43
3.12.2 Design considerations for SIM card holder	43
3.13 General purpose input & output (GPIO)	45
3.14 ADC	45
3.15 Behaviors of the RI line (Serial port1 interface only)	45
3.16 Network status indication LED lamp	46
4 Antenna interface	48
4.1 Antenna installation	48
4.1.1 Antenna pad	48
4.2 Module RF output power	49
4.3 Module RF receive sensitivity	49
4.4 Module operating frequencies	49
5 Electrical, reliability and radio characteristics	50
5.1 Absolute maximum ratings	50
5.2 Operating temperatures	50
5.3 Power supply rating	50
5.4 Current consumption	51
5.5 Electro-Static discharge	52
6 Mechanics	53
6.1 Mechanical dimensions of SIM300DZ	53
6.2 PIN assignment of SIM300DZ	56
6.3 The ramp-soak-spike reflow profile of SIM300DZ	58

Table Index

TABLE 1: RELATED DOCUMENTS	8
TABLE 2: TERMS AND ABBREVIATIONS	9
TABLE 3: SIM300DZ KEY FEATURES	12
TABLE 4: CODING SCHEMES AND MAXIMUM NET DATA RATES OVER AIR INTERFACE ..	13
TABLE 5: PIN DESCRIPTION	14
TABLE 6: OVERVIEW OF OPERATING MODES.....	16
TABLE 7: AT COMMANDS USED IN ALARM MODE	21
TABLE 8: SPEC OF RECOMMENDED BATTERY PACK	25
TABLE 9: OPERATING MODES	27
TABLE 10: AT COMMAND USUALLY USED IN GHOST MODE	28
TABLE 11: SUMMARY OF STATE TRANSITIONS.....	30
TABLE 12: LOGIC LEVELS OF SERIAL PORTS PINS.....	34
TABLE 13: AUDIO INTERFACE SIGNAL.....	38
TABLE 14: MIC INPUT CHARACTERISTICS	41
TABLE 15: AUDIO OUTPUT CHARACTERISTICS	41
TABLE 16: SIGNAL OF SIM INTERFACE	42
TABLE 17: PIN DESCRIPTION (AMPHENOL SIM CARD HOLDER)	44
TABLE 18: PIN DESCRIPTION (MOLEX SIM CARD HOLDER)	44
TABLE 19: GPO OF SIM300DZ.....	45
TABLE 20: ADC PIN OF SIM300DZ	45
TABLE 21: BEHAVIOURS OF THE RI LINE.....	45
TABLE 22: WORKING STATE OF NETWORK STATUS INDICATION LED PIN	47
TABLE 23: SIM300DZ CONDUCTED RF OUTPUT POWER	49
TABLE 24: SIM300DZ CONDUCTED RF RECEIVE SENSITIVITY	49
TABLE 25: SIM300DZ OPERATING FREQUENCIES	49
TABLE 26: ABSOLUTE MAXIMUM RATING.....	50
TABLE 27: SIM300DZ OPERATING TEMPERATURE.....	50
TABLE 28: SIM300DZ POWER SUPPLY RATING	50
TABLE 29: PIN ASSIGNMENT.....	56

Figure Index

FIGURE 1: VBAT INPUT.....	18
FIGURE 2: VBAT VOLTAGE DROP DURING TRANSMIT BURST	18
FIGURE 3: TIMING OF TURN ON SYSTEM	20
FIGURE 4: TIMING OF TURN OFF SYSTEM	22
FIGURE 5: TIMING OF RESTART SYSTEM	24
FIGURE 6: BATTERY CHARGER AND PACK	24
FIGURE 7: RTC SUPPLY FROM NON-CHARGEABLE BATTERY	31
FIGURE 8: RTC SUPPLY FROM RECHARGEABLE BATTERY	31
FIGURE 9: RTC SUPPLY FROM CAPACITOR	32
FIGURE 10: PANASONIC EECEMOE204A CHARGE CHARACTERISTIC	32
FIGURE 11: MAXELL TC614 CHARGE CHARACTERISTIC	33
FIGURE 12: SEIKO TS621 CHARGE CHARACTERISTIC	33
FIGURE 13: INTERFACE OF SERIAL PORTS	35
FIGURE 14: INTERFACE OF SOFTWARE UPGRADE	37
FIGURE 16: SPEAKER INTERFACE CONFIGURATION	39
FIGURE 17: SPEAKER INTERFACE WITH AMPLIFIER CONFIGURATION	39
FIGURE 18: MICROPHONE INTERFACE CONFIGURATION	40
FIGURE 19: EARPHONE INTERFACE CONFIGURATION.....	41
FIGURE 20: SIM INTERFACE REFERENCE CIRCUIT WITH 6 PINS SIM CARD	43
FIGURE 21: AMPHENOL C707-10M006 512 2 SIM CARD HOLDER	44
FIGURE 22: SIM300DZ SERVICES AS RECEIVER	46
FIGURE 23: SIM300DZ SERVICES AS CALLER	46
FIGURE 24: REFERENCE CIRCUIT FOR NETWORK STATUS LED	47
FIGURE 25: RF PAD.....	48
FIGURE 26: SIM300DZ TOP VIEW AND SIDE VIEW	53
FIGURE 27: SIM300DZ BOTTOM VIEW	54
FIGURE 28: PAD BOTTOM VIEW	54
FIGURE 29: FOOTPRINT RECOMMENDATION.....	55
FIGURE 30: PHYSICAL SIM300DZ.....	57
FIGURE 31: BOTTOM VIEW OF SIM300DZ	57
FIGURE 32: THE RAMP-SOAK-SPIKE REFLOW PROFILE OF SIM300DZ	58

Version history

Data	Version	Description of change	Author
2006-03-8	1.00	Origin	
2006-06-27	2.01	Pin description	
2006-9-13	2.02	Delete the SIM_presence PIN Modify the figure of the timing of turn on system Modify the figure of the timing of turn off system Modify the high voltage and low voltage of the PWRKEY	
2007-01-10	02.03	Modify the SIM300DZ key features Modify the overview of operating modes Modify the MIC input characteristics Add the note in the chapter of the Serial Interfaces about RTS connected to GND	

1 Introduction

This document describes the hardware interface of the SIMCOM SIM300DZ module that connects to the specific application and the air interface. As SIM300DZ can be integrated with a wide range of applications, all functional components of SIM300DZ are described in great detail.

This document can help you quickly understand SIM300DZ interface specifications, electrical and mechanical details. With the help of this document and other SIM300DZ application notes, user guide, you can use SIM300DZ module to design and set-up mobile applications quickly.

1.1 Related documents

Table 1: Related documents

SN	Document name	Remark
[1]	SIM300DZ_ATC	SIM300DZ_ATC
[2]	ITU-T Draft new recommendation V.25ter:	Serial asynchronous automatic dialing and control
[3]	GSM 07.07:	Digital cellular telecommunications (Phase 2+); AT command set for GSM Mobile Equipment (ME)
[4]	GSM 07.05:	Digital cellular telecommunications (Phase 2+); Use of Data Terminal Equipment – Data Circuit terminating Equipment (DTE – DCE) interface for Short Message Service (SMS) and Cell Broadcast Service (CBS)
[5]	GSM 11.14:	Digital cellular telecommunications system (Phase 2+); Specification of the SIM Application Toolkit for the Subscriber Identity Module – Mobile Equipment (SIM – ME) interface
[6]	GSM 11.11:	Digital cellular telecommunications system (Phase 2+); Specification of the Subscriber Identity Module – Mobile Equipment (SIM – ME) interface
[7]	GSM 03.38:	Digital cellular telecommunications system (Phase 2+); Alphabets and language-specific information
[8]	GSM 11.10	Digital cellular telecommunications system (Phase 2); Mobile Station (MS) conformance specification; Part 1: Conformance specification

1.2 Terms and abbreviations

Table 2: Terms and abbreviations

Abbreviation	Description
ADC	Analog-to-Digital Converter
ARP	Antenna Reference Point
ASIC	Application Specific Integrated Circuit
BER	Bit Error Rate
BTS	Base Transceiver Station
CHAP	Challenge Handshake Authentication Protocol
CS	Coding Scheme
CSD	Circuit Switched Data
CTS	Clear to Send
DAC	Digital-to-Analog Converter
DRX	Discontinuous Reception
DSP	Digital Signal Processor
DTE	Data Terminal Equipment (typically computer, terminal, printer)
DTR	Data Terminal Ready
DTX	Discontinuous Transmission
EFR	Enhanced Full Rate
EGSM	Enhanced GSM
EMC	Electromagnetic Compatibility
ESD	Electrostatic Discharge
ETS	European Telecommunication Standard
FCC	Federal Communications Commission (U.S.)
FDMA	Frequency Division Multiple Access
FR	Full Rate
GMSK	Gaussian Minimum Shift Keying
GPRS	General Packet Radio Service
GSM	Global Standard for Mobile Communications
HR	Half Rate
I/O	Input/Output
IC	Integrated Circuit
IMEI	International Mobile Equipment Identity
kbps	Kilo bits per second
LED	Light Emitting Diode
Li-Ion	Lithium-Ion

SIM300DZ Hardware Design

MO	Mobile Originated
Abbreviation	Description
MS	Mobile Station (GSM engine), also referred to as TE
MT	Mobile Terminated
PAP	Password Authentication Protocol
PBCCH	Packet Switched Broadcast Control Channel
PCB	Printed Circuit Board
PCS	Personal Communication System, also referred to as GSM 1900
PDU	Protocol Data Unit
PPP	Point-to-point protocol
RF	Radio Frequency
RMS	Root Mean Square (value)
RTC	Real Time Clock
Rx	Receive Direction
SIM	Subscriber Identification Module
SMS	Short Message Service
TDMA	Time Division Multiple Access
TE	Terminal Equipment, also referred to as DTE
TX	Transmit Direction
URC	Unsolicited Result Code
USSD	Unstructured Supplementary Service Data
VSWR	Voltage Standing Wave Ratio
Phonebook abbreviations	
FD	SIM fix dialing phonebook
LD	SIM last dialing phonebook (list of numbers most recently dialed)
MC	Mobile Equipment list of unanswered MT calls (missed calls)
ME	Mobile Equipment phonebook
RC	Mobile Equipment list of received calls
SM	SIM phonebook
DC	ME dialed calls list(+CPBW may not be applicable or this storage)(same as LD)
LA	Last Number All list (LND/LNM/LNR)
ON	SIM (or ME) own numbers (MSISDNs) list
SD	SIM service dial number
VM	SIM voice mailbox
BN	SIM barred dialed number

2 Product concept

Designed for global market, SIM300DZ is tri-band GSM/GPRS engine that works on frequencies, GSM 900 MHz, DCS 1800 MHz and PCS1900 MHz. SIM300DZ features GPRS multi-slot class 10 /Class 8^① capability and supports the GPRS coding schemes CS-1, CS-2, CS-3 and CS-4.

① SIM300DZ also provides GPRS multi-slot class 8 and the default is class 10.

With a tiny configuration of 33mm x 33mm x 3 mm, SIM300DZ can fit almost all the space requirement in your application, such as smart phone, PDA phone, Car Phone , Wireless PSTN , and other mobile device.

The hardware package of 48 pins

- 9 GND PINS and 2 VBAT pins
- 1 pin is programmable as General Purpose I/O .This gives you the flexibility to develop customized applications.
- Serial port and Debug port can help you easily develop your applications. But they can not work at the same time.
- Two audio channels include two microphone inputs and two speaker outputs. This can be easily configured by AT command.

With the charge circuit integrated inside the SIM300DZ, it is very suitable for the battery power application.

The SIM300DZ provides RF antenna interface. And customer's antenna should be located in the customer's mainboard and connect to module's antenna pad through micro strip line or other type RF traces whose impedance must be controlled in 50Ω.

The SIM300DZ is designed with power saving technique, the current consumption is as low as 2.5mA in SLEEP mode (BS-PA-MFRMS=5).

The SIM300DZ is integrated with the TCP/IP protocol, Extended TCP/IP AT commands are developed for customers to use the TCP/IP protocol easily, which is useful for those data transfer applications.

2.1 SIM300DZ key features at a glance

Table 3: SIM300DZ key features

Feature	Implementation
Power supply	Single supply voltage 3.4V – 4.5V
Power saving	Typical power consumption in SLEEP mode to 2.5mA (BS-PA-MFRMS=5)
Charging	Supports charging control for Li-Ion battery
Frequency bands	<ul style="list-style-type: none"> ● SIM300DZ tri-band: GSM 900, DCS 1800, PCS 1900. The SIM300DZ can search the 3 frequency bands automatically. The frequency bands also can be set by AT command. ● Compliant to GSM Phase 2/2+
GSM class	Small MS
Transmit power	<ul style="list-style-type: none"> ● Class 4 (2W) at EGSM900 ● Class 1 (1W) at DCS1800 and PCS 1900
GPRS connectivity	<ul style="list-style-type: none"> ● GPRS multi-slot class 8 (optional) ● GPRS multi-slot class 10 (default) ● GPRS mobile station class B
Temperature range	<ul style="list-style-type: none"> ● Normal operation: -20°C to +55°C ● Restricted operation: -30°C to -20°C and +55°C to +80°C ● Storage temperature -40°C to +80°C
DATA GPRS:	<ul style="list-style-type: none"> ● GPRS data downlink transfer: max. 85.6 kbps ● GPRS data uplink transfer: max. 42.8 kbps ● Coding scheme: CS-1, CS-2, CS-3 and CS-4 ● SIM300DZ supports the protocols PAP (Password Authentication Protocol) usually used for PPP connections. ● The SIM300DZ integrates the TCP/IP protocol. ● Support Packet Switched Broadcast Control Channel (PBCCH)
CSD:	<ul style="list-style-type: none"> ● CSD transmission rates: 2.4, 4.8, 9.6, 14.4 kbps, non-transparent ● Unstructured Supplementary Services Data (USSD) support
SMS	<ul style="list-style-type: none"> ● MT, MO, CB, Text and PDU mode ● SMS storage: SIM card
FAX	Group 3 Class 1
SIM interface	Support SIM card: 1.8V ,3V
External antenna	Connected via 50 Ohm antenna connector or antenna pad
Audio features	Speech codec modes: <ul style="list-style-type: none"> ● Half Rate (ETS 06.20) ● Full Rate (ETS 06.10) ● Enhanced Full Rate (ETS 06.50 / 06.60 / 06.80)

SIM300DZ Hardware Design

	<ul style="list-style-type: none"> ● Echo suppression
Serial interface and Debug interface	<ul style="list-style-type: none"> ● Serial Port: Seven lines on Serial Port Interface ● Serial Port can be used for CSD FAX, GPRS service and sending AT command of controlling module. ● Autobauding supports baud rates from 1200 bps to 115200bps. ● Debug port : provide two lines on Serial Port Interface /TXD and /RXD ● Debug port is only used for transmitting AT command.
Phonebook management	Support phonebook types: SM, FD, LD, MC, RC, ON, ME,BN,VM,LA,DC,SD
SIM Application Toolkit	Support SAT class 3, GSM 11.14 Release 99
Real time clock	Implemented
Timer function	Programmable via AT command
Physical characteristics	Size: 33±0.15 x 33±0.15 x 3±0.3 mm Weight: 8g
Firmware upgrade	Firmware upgrade over serial interface

Table 4: Coding schemes and maximum net data rates over air interface

Coding scheme	1 Timeslot	2 Timeslot	4 Timeslot
CS-1:	9.05kbps	18.1kbps	36.2kbps
CS-2:	13.4kbps	26.8kbps	53.6kbps
CS-3:	15.6kbps	31.2kbps	62.4kbps
CS-4:	21.4kbps	42.8kbps	85.6kbps

3 Application interface

All hardware interfaces are described in detail in following chapters:

- Power supply and charging control (*see Chapters 3.3 and 3.5*)
- Provide serial interface and Debug interface (*see chapter 3.9*)
- Two analog audio interfaces (*see chapter 3.10*)
- SIM interface (*see chapter 3.11*)

3.1 SIM300DZ pin description

Table 5: Pin description

Power Supply			
PIN NAME	I/O	DESCRIPTION	
VBAT		2 VBAT pins are dedicated to connect the supply voltage. The power supply of SIM300DZ has to be a single voltage source of VBAT= 3.4V...4.5V. It must be able to provide sufficient current in a transmit burst which typically rises to 2A. mostly, these 2 pins are voltage input, however, when use the charge circuit to charge the battery, these pins become the current output, select one of these pins as the charge current output pin	Vmax= 4.5V Vmin=3.4V Vnorm=4.0V
VRTC	I/O	Current input for RTC when the battery is not supplied for the system. Current output for backup battery when the main battery is present and the backup battery is in low voltage state.	Vmax=2.0V Vmin=1.2V Vnorm=1.8V I norm= 20uA
VCHG	I	Voltage input for the charge circuit, as the signal for detecting the charger connecting	Vmax=5.25V Vmin=1.1 * VBAT Vnorm=5.1V Imin=650mA

GND		Digital ground	
Power on or power off			
PIN NAME	I/O	DESCRIPTION	
PWRKEY	I	Voltage input for power on key. Press the key , the PWRKEY get a low level voltage for user to power on or power off the system, the user should keep pressing the key for a moment when power on or power off the system. Because the system need margin time assert the software.	$V_{ILmax}=0.2*V_{BAT}$ $V_{IHmin}=0.6*V_{BAT}$ $V_{Imax}=V_{BAT}$
Audio interfaces			
PIN NAME	I/O	DESCRIPTION	
MIC1P MIC1N	I	Positive and negative voiceband input	Audio DC Characteristics refer to chapter 3.10
MIC2P MIC2N	I	Auxiliary positive and negative voiceband input	
SPK1P SPK1N	O	Positive and negative voiceband output	
SPK2P SPK2N	O	Auxiliary positive and negative voiceband output	
AGND		Analog ground	
GERNERAL PURPOSE input/output			
PIN NAME	I/O	DESCRIPTION	
STATUS	O	Indicate work status	$V_{ILmin}=0V$
GPO1	O	Normal Output Port	$V_{ILmax}=0.3 *V_{DD_EXT}$
DISP_DATA	I/O	Display interface	$V_{IHmin}=0.7*V_{DD_EXT}$
DISP_CLK	O		$V_{IHmax}= V_{DD_EXT}+0.3$
DISP_CS	O		$V_{OLmin}=GND$
DISP_D/C	O		$V_{OLmax}=0.2V$
DISP_RST	O		$V_{OHmin}= V_{DD_EXT}-0.2$
KBR0	I		$V_{OHmax}= V_{DD_EXT}$
Serial interface			
PIN NAME	I/O	DESCRIPTION	
RXD	I	Receive data	$V_{ILmin}=0V$
DTR	I	Data terminal Ready	$V_{ILmax}=0.3*V_{DD_EXT}$
TXD	O	Transmit data	$V_{IHmin}=0.7*V_{DD_EXT}$
RTS	I	Request to send	$V_{IHmax}= V_{DD_EXT}+0.3$

SIM300DZ Hardware Design

CTS	O	Clear to send	VOLmin=GND
RI	O	Ring indicator	VOLmax=0.2V VOHmin= VDD_EXT-0.2 VOHmax= VDD_EXT
Debug interface			
DBG_TXD	O	Serial interface for debugging and communication	
DBG_RXD	I		
SIM interface			
PIN NAME	I/O	DESCRIPTION	
SIM_VDD	O	Voltage supply for SIM card	The voltage can be select by software either 1.8v or 3V
SIM_DATA	I/O	SIM data output	VILmin=0V
SIM_CLK	O	SIM clock	VILmax=0.3*SIM_VDD
SIM_RST	O	SIM reset	VIHmin=0.7*SIM_VDD VIHmax= SIM_VDD+0.3 VOLmin=GND VOLmax=0.2V VOHmin= SIM_VDD-0.2 VOHmax= SIM_VDD
ADC			
PIN NAME	I/O	DESCRIPTION	
ADC0	I	General purpose analog to digital converter.	Input voltage value scope 0V to 2.4V
TEMP_BAT	I	For measure the battery temperature	

3.2 Operating modes

The table below briefly summarizes the various operating modes referred to in the following chapters.

Table 6: Overview of operating modes

Mode	Function	
Normal operation	GSM/GPRS SLEEP	Module will automatically go into SLEEP mode if DTR is set to high level and there is no on air or audio activity is required and no hardware interrupt (such as GPIO interrupt or data on serial port). In this case, the current consumption of module will reduce to the minimal level. During sleep mode, the module can still receive paging

		message and SMS from the system normally.
	GSM IDLE	Software is active. Module has registered to the GSM network, and the module is ready to send and receive.
	GSM TALK	Connection is going on between two subscribers. In this case, the power consumption depends on network settings such as DTX off/on, FR/EFR/HR, hopping sequences, antenna.
	GPRS STANDBY	Module is ready for GPRS data transfer, but no data is currently sent or received. In this case, power consumption depends on network settings and GPRS configuration (e.g. multi-slot settings).
	GPRS DATA	There is GPRS data in transfer (PPP or TCP or UDP). In this case, power consumption is related with network settings (e.g. power control level), uplink / downlink data rates and GPRS configuration (e.g. used multi-slot settings).
POWER DOWN		Normal shutdown by sending the “AT+CPOWD” command or using the PWRKEY. The power management ASIC disconnects the power supply from the baseband part of the module, only the power supply for the RTC is remained. Software is not active. The serial interfaces are not accessible. Operating voltage (connected to BATT+) remains applied.
Minimum functionality mode (without remove power supply)		Use the “AT+CFUN” command can set the module to a minimum functionality mode without remove the power supply. In this case, the RF part of the module will not work or the SIM card will not be accessible, or RF part and SIM card will be closed all, the serial interfaces is still accessible. The power consumption in this case is very low.
Alarm mode		RTC alert function launches this restricted operation while the module is in POWER DOWN mode. SIM300DZ will not be registered to GSM network and only parts of AT commands can be available.
GHOST Mode (Charge-only mode)		GHOST mode means off and charging mode. In this mode, the module can not be registered to GSM network and only limited AT commands can be accessible, the following way will launch GHOST mode: <ul style="list-style-type: none"> ● From POWER DOWN mode: Connect charger to the module’s VCHG pin and VBAT pin while SIM300DZ is power down. ● From Normal mode: Connect charger to the module’s VCHG pin and VBAT pin, then power down the module by “AT+CPOWD”
Charge mode during normal operation		Start charging while the module is in normal mode including: SLEEP, IDLE, TALK, GPRS IDLE and GPRS DATA)

3.3 Power supply

The power supply of SIM300DZ is from a single voltage source of $V_{BAT} = 3.4V \dots 4.5V$. In some case, the ripple in a transmit burst may cause voltage drops when current consumption rise to typical peaks of 2A, So the power supply must be able to provide sufficient current up to 2A..

For the VBAT input, a local bypass capacitor is recommended. A capacitor (about $100\mu F$, low ESR) is recommended. Multi-layer ceramic chip (MLCC) capacitors can provide the best combination of low ESR and small size but may not be cost effective. A lower cost choice may be a $100\mu F$ tantalum capacitor (low ESR) with a small ($0.1\mu F$ to $1\mu F$) ceramic in parallel, which is illustrated as figure1. And the capacitors should be put as closer as possible to the SIM300DZ VBAT pins.

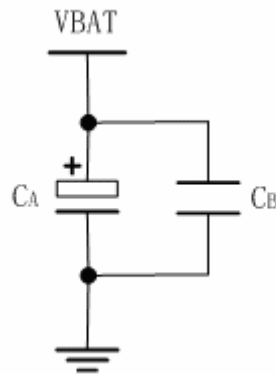

Figure 1: VBAT input

The following figure is the VBAT voltage ripple wave at the maximum power transmit phase, the test condition is $V_{BAT} = 4.0V$, VBAT maximum output current = 2A, $C_A = 100\mu F$ tantalum capacitor (ESR = 0.7Ω) and $C_B = 1\mu F$.



Figure 2: VBAT voltage drop during transmit burst

3.3.1 Power supply pins

Two VBAT pins of SIM300DZ are dedicated to connect the supply voltage. Nine GND pins are recommended for grounding. The VCHG pin serves as a control signal for charging a Li-Ion battery. VRTC pin can be used to back up the RTC.

3.3.2 Minimizing power losses

Please pay special attention to the supply power when you are designing your applications. Please make sure that the input voltage will never drop below 3.4V even in a transmit burst during which the current consumption may rise up to 2A. If the power voltage drops below 3.4V, the module may be switched off. You should also take the resistance from the power supply lines on the host board or from battery pack into account.

3.3.3 Monitoring power supply

To monitor the supply voltage, you can use the “AT+CBC” command which include three parameters: charge state, voltage percent and voltage value (in mV). It returns charge state, the battery voltage 1-100 percent of capacity and actual value measured at VBAT and GND.

The voltage is continuously measured at intervals depending on the operating mode. The displayed voltage (in mV) is averaged over the last measuring period before the AT+CBC command was executed.

For details please refer to *document [1]*

3.4 Power up / down scenarios

3.4.1 Turn on SIM300DZ

SIM300DZ can be turned on by various ways, which are described in following chapters:

- Via PWRKEY pin: starts normal operating mode (see chapter 3.2);
- Via VCHG pin: starts GHOST modes (see chapter 3.4.1.2);
- Via RTC interrupt: starts ALARM modes (see chapter 3.4.1.4)

Note: Only enter AT command through serial port after SIM300DZ is power on and Unsolicited Result Code “RDY” is received from serial port. If configured to a fixed baud rate, SIM300DZ will send the result code “RDY” to indicate that it is ready to operate. This result code does not appear when autobauding is active. You can use AT+IPR=x:&W to set a fixed baud rate and save the configuration to non-volatile flash memory. See Chapter AT+IPR in document [1].

3.4.1.1 Turn on SIM300DZ using the PWRKEY pin (Power on)

You can turn on the SIM300DZ by driving the PWRKEY to a low level voltage for period time. The power on scenarios illustrate as figure3.

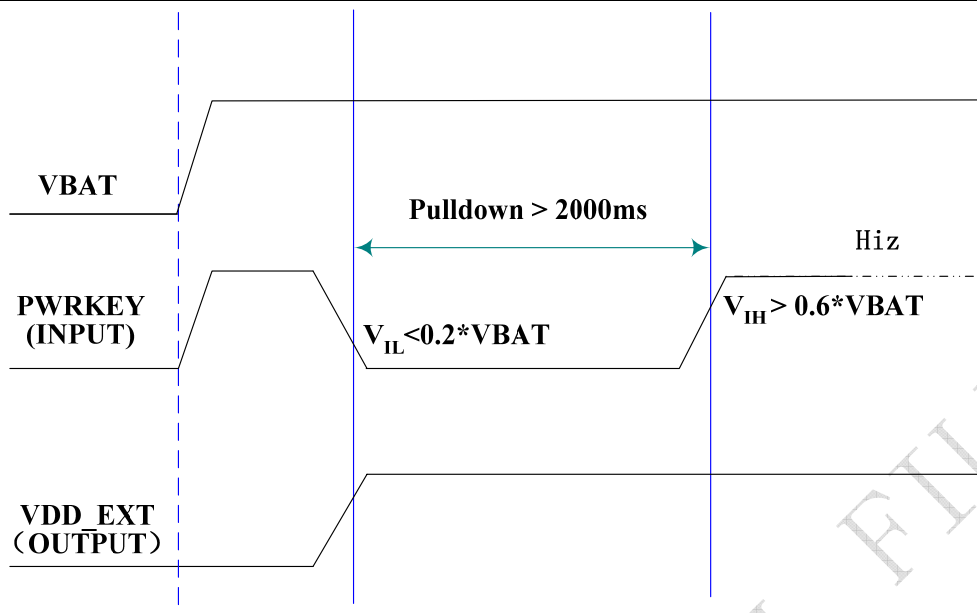

Figure 3: Timing of turn on system

When power on procedure completed, SIM300DZ will send out following result code to indicate the module is ready to operate, when set as fixed baud rate. STATUS pin will drive to 2.8V and keep this level when in work mode. If configured to a fixed baud rate, SIM300DZ will send the result code “RDY” to indicate that it is ready to operate. This result code does not appear when autobauding is active.

RDY

3.4.1.2 Turn on the SIM300DZ using the VCHG signal

As described in chapter 3.4, charger can be connected to SIM300DZ’s VCHG pin regardless of the module’s operating mode.

If the charger is connected to the module’s VCHG pin while SIM300DZ is in POWER DOWN mode, SIM300DZ will go into the GHOST mode (Off and charging). In this mode, the module will not register to network, and only a few AT commands can work in this mode. For detailed information please refers to chapter 3.5.

When module is powered on using the VCHG signal, SIM300DZ sends out result code as following when fixed baud rate:

RDY

GHOST MODE

In GHOST mode, by driving the PWRKEY to a low level voltage for period time (Please refer to the power on scenarios in 3.4), SIM300DZ will power up and go into charge mode (charging in normal mode), all operation and AT commands can be available. In this case, SIM300DZ will send out result code as following:

From GHOST MODE to NORMAL MODE

3.4.1.3 Turn on SIM300DZ using the RTC (Alarm mode)

Alarm mode is a power-on approach by using the RTC. The alert function of RTC makes the SIM300DZ wake up while the module power off. In alarm mode, SIM300DZ will not register to GSM network and the software protocol stack is closed. Thus the parts of AT commands related with SIM card and Protocol stack will not be accessible, and the others can be used as well as in normal mode.

Use the AT+CALARM command to set the alarm time. The RTC remains the alarm time if SIM300DZ power down by “AT+CPOWD=1” or by PWRKEY pin. Once the alarm time expired and executed, SIM300DZ goes into the Alarm mode. In this case, SIM300DZ will send out an Unsolicited Result Code (URC) when set as fixed baud rate:

RDY

ALARM MODE

During Alarm mode, use AT+CFUN command to query the status of software protocol stack; it will return 0 which indicates that the protocol stack is closed. Then after 90s, SIM300DZ will power down automatically. However, during Alarm mode, if the software protocol is started by AT+CFUN=1 command, the process of automatic power down will not be available. In ALARM mode, driving the PWRKEY to a low level voltage for a period time will cause SIM300DZ enter into power down mode. (Please refer to the power down scenarios).

The table follow briefly summarizes the AT commands that are used usually during alarm mode, for details of the instructions refer to *document [1]*:

Table 7: AT commands used in Alarm mode

AT command	USE
AT+CALARM	Set alarm time
AT+CCLK	Set data and time of RTC
AT+CPOWD	Power down
AT+CFUN	Start or close the protocol stack

3.4.2 Turn off SIM300DZ

Following procedure can be used to turn off the SIM300DZ:

- Normal power down procedure: Turn off SIM300DZ using the PWRKEY pin
- Normal power down procedure: Turn off SIM300DZ using AT command
- Under-voltage automatic shutdown: Take effect if Under-voltage is detected
- Over-temperature automatic shutdown: Take effect if Over-temperature is detected

3.4.2.1 Turn off SIM300DZ using the PWRKEY pin (Power down)

You can turn off the SIM300DZ by driving the PWRKEY to a low level voltage for a period time. The power down scenarios illustrate as figure4.

This procedure will make the module log off from the network and allow the software to enter into a secure state and save data before completely disconnect the power supply.

Before the completion of the switching off procedure the module will send out result code:

POWER DOWN

After this moment, the AT commands can not be executed. Module enters the POWER DOWN mode, only the RTC is still active. POWER DOWN can also be indicated by STATUS pin, which is a low level voltage in this mode.

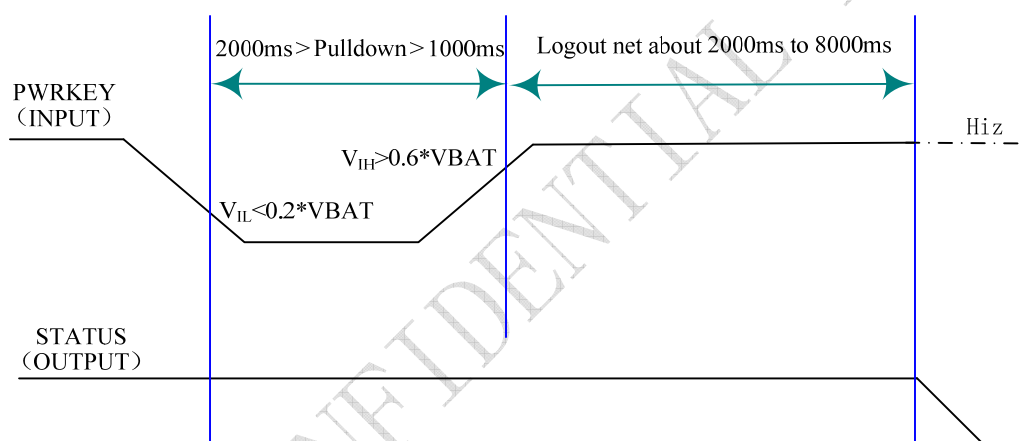

Figure 4: Timing of turn off system

3.4.2.2 Turn off SIM300DZ using AT command

You can use an AT command “AT+CPOWD=1” to turn off the module. This command will make the module log off from the network and allow the software to enter into a secure state and save data before completely disconnect the power supply.

Before switching off, the module will send out result code:

NORMAL POWER DOWN

After this moment, any AT commands can not be executed. Module enters into the POWER DOWN mode, only the RTC is still active. POWER DOWN can also be indicated by STATUS pin, which is a low level voltage in this mode.

Please refer to *document [1]* for detail about the AT command of “AT+CPOWD”.

3.4.2.3 Under-voltage Automatic shutdown

Software will constantly monitor the voltage applied on the VBAT, if the measured battery voltage is no more than 3.5V, the module will send out result code:

POWER LOW WARNING

If the measured battery voltage is no more than 3.4V, the following URC will be presented:

POWER LOW DOWN

After this moment, no further more AT commands can be executed. The module will log off from network and enter POWER DOWN mode, only the RTC is still active. POWER DOWN can also be indicated by STATUS pin, which is a low level voltage in this mode.

3.4.2.4 Over-temperature automatic shutdown

Software will constantly monitor the temperature of the module, if the measured temperature is equal or higher than 80°C, the following URC will be presented:

+CMTE:1

If the measured temperature $\leq -30^{\circ}\text{C}$, the following URC will be presented:

+CMTE:-1

The uncritical temperature range is -35°C to 85°C . If the measured temperature $\geq 85^{\circ}\text{C}$ or $\leq -35^{\circ}\text{C}$, the module will be automatic shutdown soon.

If the measured temperature $\geq 85^{\circ}\text{C}$, the following URC will be presented:

+CMTE:2

If the measured temperature $\leq -35^{\circ}\text{C}$, the following URC will be presented:

+CMTE:-2

After this moment, the AT commands can not be executed. The module will log off from network and enter into POWER DOWN mode, only the RTC is still active. POWER DOWN can also be indicated by STATUS pin, which is a low level voltage in this mode.

To monitor the temperature, you can use the “AT+CMTE” command to measure the temperature when the module is power on.

For details please refer to *document [1]*

3.4.3 Restart SIM300DZ using the PWRKEY pin

You can restart SIM300DZ by driving the PWRKEY to a low level voltage for period time, same as turn on SIM300DZ using the PWRKEY pin. Before restart the SIM300DZ, you need delay at least 500ms from detecting the STATUS low level on. The restart scenarios illustrate as the following figure.

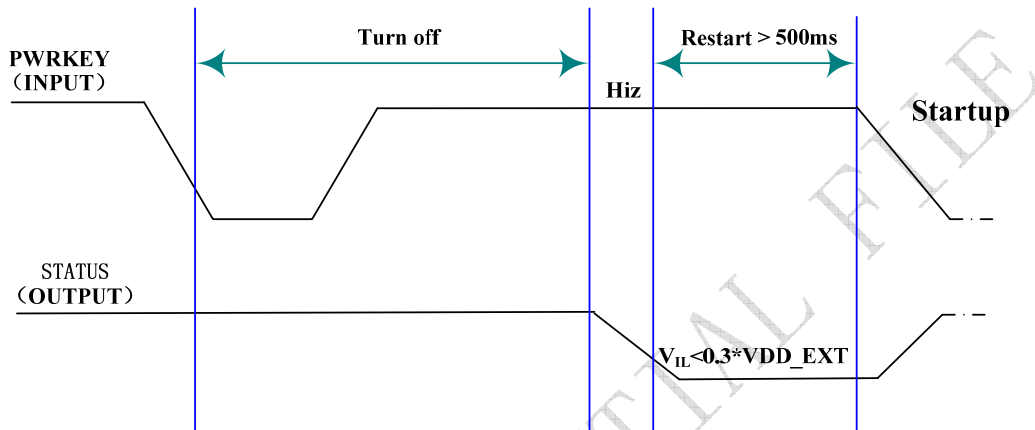

Figure 5: Timing of restart system

3.5 Charging interface

SIM300DZ has integrated a charging circuit inside the module for Li-Ion batteries charging control, which make it very convenient for applications to manage their battery charging. A common connection is shown in the following figure:

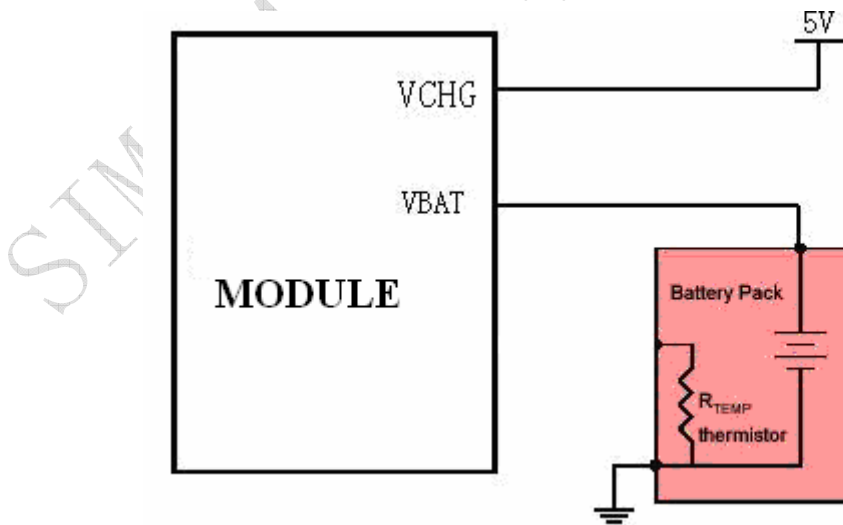

Figure 6: Battery charger and pack

The function of detecting the temperature of battery should be supported by the software in the module. It's a customization function. The R_{TEMP} is a NTC thermistor. We recommend to use

NCP15XH103F03RC from MURATA. The impedance of the NTC thermistor is 10Kohm in 25°C. Please refer to the fore figure for the reference circuit.

3.5.1 Battery pack characteristics

SIM300DZ has optimized the charging algorithm for the Li-Ion battery that meets the characteristics listed below. To use SIM300DZ's charging algorithm properly, it is recommended that the battery pack you integrated into your application is compliant with these specifications. The battery pack compliant with these specifications is also important for the AT command "AT+CBC" to monitor the voltage of battery, or the "AT+CBC" may return incorrect battery capacity values.

- The maximum charging voltage of the Li-Ion battery pack is 4.2V and the recommended capacity is 580mAh. If the Battery packs with a capacity more than 580 mAh, it will cost more time for charging.
- The pack should have a protection circuit to avoid overcharging, deep discharging and over-current. This circuit should be insensitive to pulsed current.
- On the SIM300DZ, the build-in circuit of SIM300DZ's power management chipset monitors the supply voltage constantly. Once the Under-voltage is detected, the SIM300DZ will be power down automatically. Under-voltage thresholds are specific to the battery pack.
- The internal resistance of the battery and the protection circuit should be as low as possible. It is recommended not to exceed 200mΩ.
- The battery pack must be protected from reverse pole connection.

3.5.2 Recommended battery pack

Following is the spec of recommended battery pack:

Table 8: Spec of recommended battery pack

Product name & type	BYD, Li-Ion, 3.7V, 580mAh
To obtain more information Please contact :	BYD COMPANY LIMITED
Normal voltage	3.7V
Capacity	NORMAL 580mAh
Charge Voltage	4.200±0.049V
Max Charge Current	1.5C
Charge Method	CC / CV (Constant Current / Constant Voltage)
Max Discharge Current	1.5C (for continuous discharging mode)
Discharge Cut-off Voltage	2.75V/ cell

Internal resistance	Initial $\leq 200\text{m}\Omega$ After 400cycles $\leq 270\text{m}\Omega$
---------------------	--

3.5.3 Implemented charging technique

The SIM300DZ include the function for battery charging. There are three pins in the connector related with the battery charging function: VCHG, VBAT and BAT_TEMP pins. The VCHG pin is driven by an external voltage, system can use this pin to detect a charger supply and provide most charging current through SIM300DZ module to battery when charging is in fast charge state. The VBAT give out charging current from SIM300DZ module to external battery. BAT_TEMP pin is for user to measure the battery temperature. Just let this pin open if battery temperature measuring is not your concern.

So it is very simple to implement charging technique, you need only connect the charger to the VCHG pin and connect the battery to the VBAT pin.

The SIM300DZ detect charger supply and the battery is present, battery charging will happen. If there is no charger supply or no battery present the charging will not be enabled.

Normally, there are three main states in whole charging procedure.

- DDLO charge and UVLO charge;
- Fast charge;
- Trickle charge;

DDLO charge and UVLO charge:

DDLO (deep discharge lock out) is the state of battery when its voltage is under 2.4V. And UVLO (under voltage lock out) means the battery voltage less than 3.2V and more than 2.4V. The battery is not suitable for fast charge when its condition is DDLO or UVLO. The SIM300DZ provides a small constant current to the battery when the battery is between DDLO and UVLO. In DDLO charge, SIM300DZ gives out 5mA current to the battery. And in UVLO charge, SIM300DZ provides about 25mA current to the battery.

DDLO charge terminated when the battery voltage reaches 2.4V. UVLO charge terminated when the battery voltage is up to 3.2V. Both DDLO and UVLO charge are controlled by the SIM300DZ hardware only.

Fast charge:

If there is a charger supply and battery present and the battery is not in DDLO and UVLO, SIM300DZ will enter fast charge state. Fast charge is controlled by the software. Fast charge delivers a strong and constant current (about 550mA) through VBAT pin to the battery until battery voltage reach 4.2V.

Trickle charge:

After fast charging, the battery voltage is close to the whole battery capacity, trickle charge begins.

In this state, the SIM300DZ charges the battery under constant voltage.

3.5.4 Operating modes during charging

The battery can be charged during various operating mode. That means that when the GSM engine is in Normal mode (SLEEP, IDLE, TALK, GPRS IDLE or GPRS DATA mode), charging can be in progress while SIM300DZ remains operational (In this case the voltage supply should be sufficient). Here we name Charging in Normal mode as Charge mode.

If the charger is connected to the module's VCHG pin and the battery is connected to the VBAT pin while SIM300DZ is in POWER DOWN mode, SIM300DZ will go into the GHOST mode (Off and charging). The following table gives the difference between Charge mode and GHOST mode:

Table 9: operating modes

	How to activate mode	Features
Charge Mode	Connect charger to module's VCHG pin and connect battery to VBAT pin of module while SIM300DZ is in Normal operating mode, including: IDLE, TALK mode; SLEEP mode etc;	<ul style="list-style-type: none"> ● GSM remains operational and registered GSM network while charging is in progress; ● The serial interfaces are available in IDLE, TALK mode, the AT command set can be used fully in this case; In SLEEP mode, the serial interfaces are not available, once the serial port is connected and there is data in transfer. Then SIM300DZ will exit the SLEEP mode.
GHOST Mode	Connect charger to module's VCHG pin while SIM300DZ is in POWER DOWN mode. IMPORTANT: Here GHOST mode is OFF and Charging mode, it means that not all software tasks are running.	<ul style="list-style-type: none"> ● Battery can be charged when GSM engine is not registered to GSM network; ● Only a few AT commands is available as listed below.

Note:

VBAT can not provide much more than 5mA current while SIM300DZ module is during the DDLO charge state. In other words it is strongly recommended that VBAT should not be the main power supply in the application subsystem while SIM300DZ module is during the DDLO charge state.

Table 10: AT Command usually used in GHOST mode

AT command	Function
AT+CALARM	Set alarm time
AT+CCLK	Set data and time of RTC
AT+CPOWD	Power down
AT+CBC	Indicated charge state and voltage
AT+CFUN	Start or close the protocol Set AT command“ AT+CFUN =1”,module can be transferred from GHOST mode to Charging in normal mode, In GHOST mode , the default value is 0

3.5.5 Charger requirements

Following is the requirements of charger for SIM300DZ.

- Simple transformer power plug
- Output voltage: 5.0V-5.25V
- Charging current limitation: 650mA
- A 10V peak voltage is allowed for maximum 1ms when charging current is switched off.
- A 1.6A peak current is allowed for maximum 1ms when charging current is switched on.

3.6 Power saving

There are two methods for the module to enter into low current consumption status. “AT+CFUN=0” is used to set module into minimum functionality mode and DTR hardware interface signal can be used to set system to be SLEEP mode (or Slow clocking mode).

3.6.1 Minimum functionality mode

Minimum functionality mode reduces the functionality of the module to a minimum and, thus, minimizes the current consumption to the lowest level. This mode is set with the “AT+CFUN” command which provides the choice of the functionality levels <fun>=0, 1, 4

- 0: minimum functionality;
- 1: full functionality (Default);
- 4: disable phone both transmit and receive RF circuits;

If SIM300DZ has been set to minimum functionality by “AT+CFUN=0”, then the RF function and SIM card function will be closed, in this case, the serial port is still accessible, but all AT commands need RF function or SIM card function will not be accessible.

SIM300DZ Hardware Design

If SIM300DZ has been set by “AT+CFUN=4”, then RF function will be closed, the serial ports is still active in this case but all AT commands need RF function will not be accessible.

After SIM300DZ has been set by “AT+CFUN=0” or “AT+CFUN=4”, it can return to full functionality by “AT+CFUN=1”.

For detailed information about “AT+CFUN”, please refer to *document [1]*.

3.6.2 SLEEP mode (slow clocking mode)

We can control SIM300DZ module to enter or exit the SLEEP mode in customer applications through DTR signal.

When DTR is in high level, at the same time there is no on air or audio activity is required and no hardware interrupt (such as GPIO interrupt or data on serial port), SIM300DZ will enter SLEEP mode automatically. In this mode, SIM300DZ can still receive paging or SMS from network.

In SLEEP mode, the serial port is not accessible.

Note: For some special soft versions, it requests to set AT command “AT+CSCLK=1” to enable the sleep mode; the default value is 0, that can’t make the module enter sleep mode, for more details please refer to the AT command list.

3.6.3 Wake up SIM300DZ from SLEEP mode

When SIM300DZ is in SLEEP mode, the following methods can wake up the module.

- Enable DTR pin to wake up SIM300DZ
If DTR Pin is pull down to a low level, this signal will wake up SIM300DZ from power saving mode. The serial port will be active after DTR change to low level about 20mS.
- Receive a voice or data call from network to wake up SIM300DZ
- Receive a SMS from network to wake up SIM300DZ
- RTC alarm expired to wake up SIM300DZ

3.7 Summary of state transitions (except SLEEP mode)

Table 11: Summary of state transitions

Further mode	POWER DOWN	Normal mode	Ghost mode (Charge-only mode)	Charging in normal	Alarm mode
Current mode					
POWER DOWN		Use PWRKEY	Connect charger to VCHG and connect battery to VBAT	No direct transition, but via “Ghost mode” or “Normal mode”	Switch on from POWER DOWN mode by RTC
Normal mode	AT+CPOWD or use PWRKEY pin		Connect charger to VCHG and connect battery to VBAT, then switch off module by AT+CPOWD or using PWRKEY	Connect charger to VCHG pin of module and connect battery to VBAT pin of module	Set alarm by “AT+CALARM”, and then switch off the module. When the timer expire, the module turn on and enter Alarm mode
Ghost mode (Charge-only mode)	Disconnect charger	No direct transition, but via “Charging in normal” mode		Turn on the module using PWRKEY OR SET AT Command “AT+CFUN=1”	Set alarm by “AT+CALARM”, when the timer expire, module will enter Alarm mode
Charging in normal	AT+CPOWD → “Ghost mode”, then disconnect charger	Disconnect the charger	Switch off module by AT+CPOWD or using PWRKEY		No direct transition
Alarm mode	Use PWRKEY pin or wait module	Use AT+CFUN	No transition	Use AT+CFUN let module enter Normal mode, then	

	switch off automatically			connect the charger to VCHG pin of module
--	--------------------------	--	--	---

3.8 RTC backup

The RTC (Real Time Clock) power supply of module can be provided by an external battery or a battery (rechargeable or non-chargeable) through VRTC pin. There is a 10K resistance which has been integrated in SIM300DZ module used for restricting current. You need only a coin-cell battery or a super-cap to VRTC pin to backup power supply for RTC.

The following figures show various sample circuits for RTC backup.

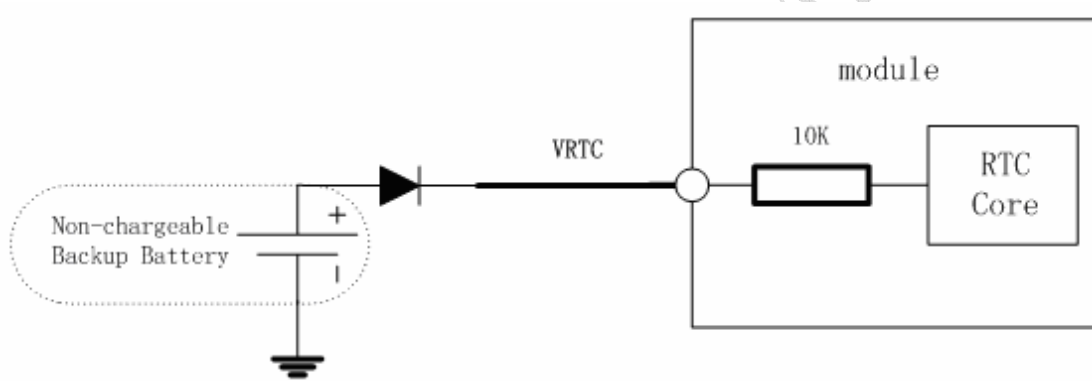

Figure 7: RTC supply from non-chargeable battery

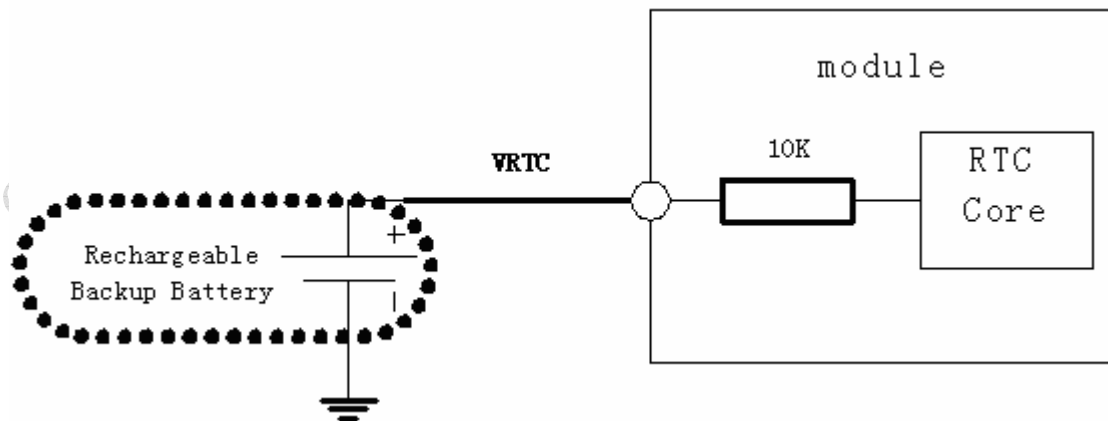

Figure 8: RTC supply from rechargeable battery

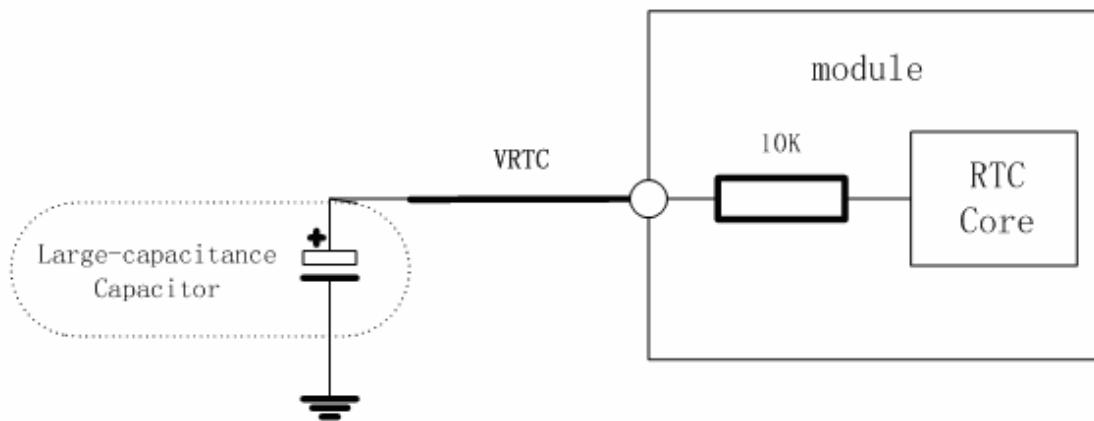

Figure 9: RTC supply from capacitor

- **Li-battery backup**

Rechargeable Lithium coin cells such as the TC614 from Maxell, or the TS621 from Seiko, are also small in size, but have higher capacity than the double layer capacitors resulting in longer backup times.

Typical charge curves for each cell type are shown in following figures. Note that the rechargeable Lithium type coin cells are generally pre-charged from the vendor.

Charger Characteristic

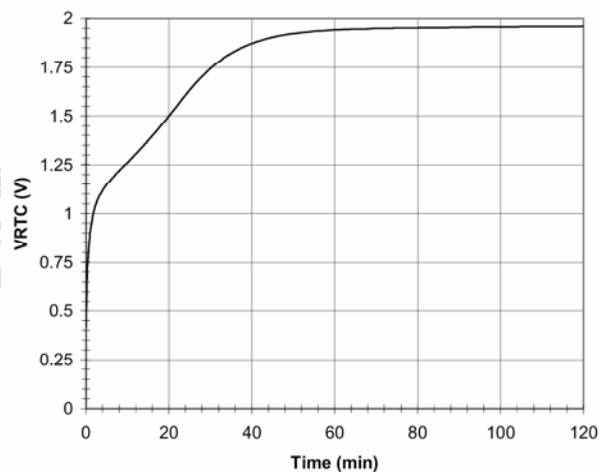

Figure 10: Panasonic EECEMOE204A Charge Characteristic

Charge characteristic

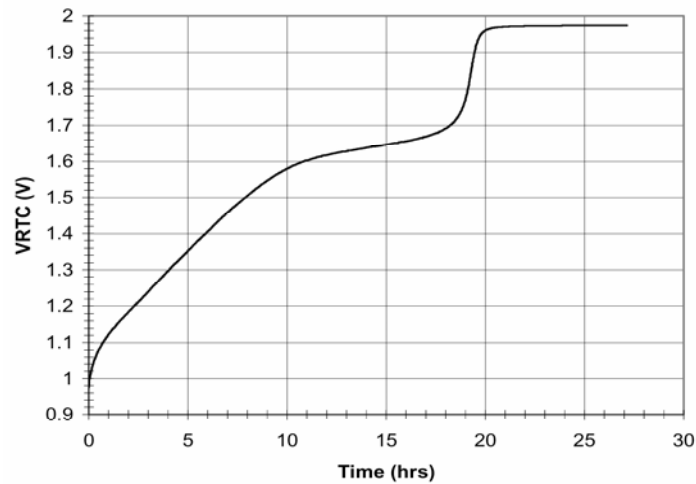

Figure 11: Maxell TC614 Charge Characteristic

Charger Characteristic

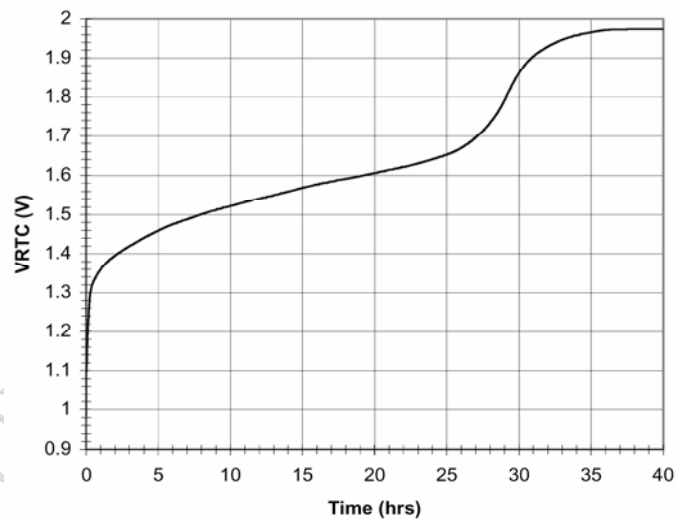

Figure 12: Seiko TS621 Charge Characteristic

Note:**Gold-capacitance backup**

Some suitable coin cells are the electric double layer capacitors available from Seiko (XC621), or from Panasonic (EECEM0E204A). They have a small physical size (6.8 mm diameter) and a nominal capacity of 0.2 F to 0.3 F, giving hours of backup time.

3.9 Serial interfaces

SIM 300D provides two unbalanced asynchronous serial ports. One is the serial port and another is the debug port. The GSM module is designed as a DCE (Data Communication Equipment), following the traditional DCE-DTE (Data Terminal Equipment) connection, the module and the client (DTE) are connected through the following signal (as figure 12 shows). Autobauding supports bit rates from 1200 bps to 115200bps.

Serial port

- Port/TXD @ Client sends data to the RXD signal line of module
- Port/RXD @ Client receives data from the TXD signal line of module

Debug port

- Port/TXD @ Client sends data to the DBG_RXD signal line of module
- Port/RXD @ Client receives data from the DBG_TXD signal line of module

NOTE: All pins of both serial ports have 8mA driver, the logic levels are described in following table

Table 12: Logic levels of serial ports pins

Parameter	Min	Max	Unit
Logic low input	0	0.3*VDD_EXT	V
Logic high input	0.7 *VDD_EXT	VDD_EXT +0.3	V
Logic low output	GND	0.2	V
Logic high output	VDD_EXT -0.2	VDD_EXT	V

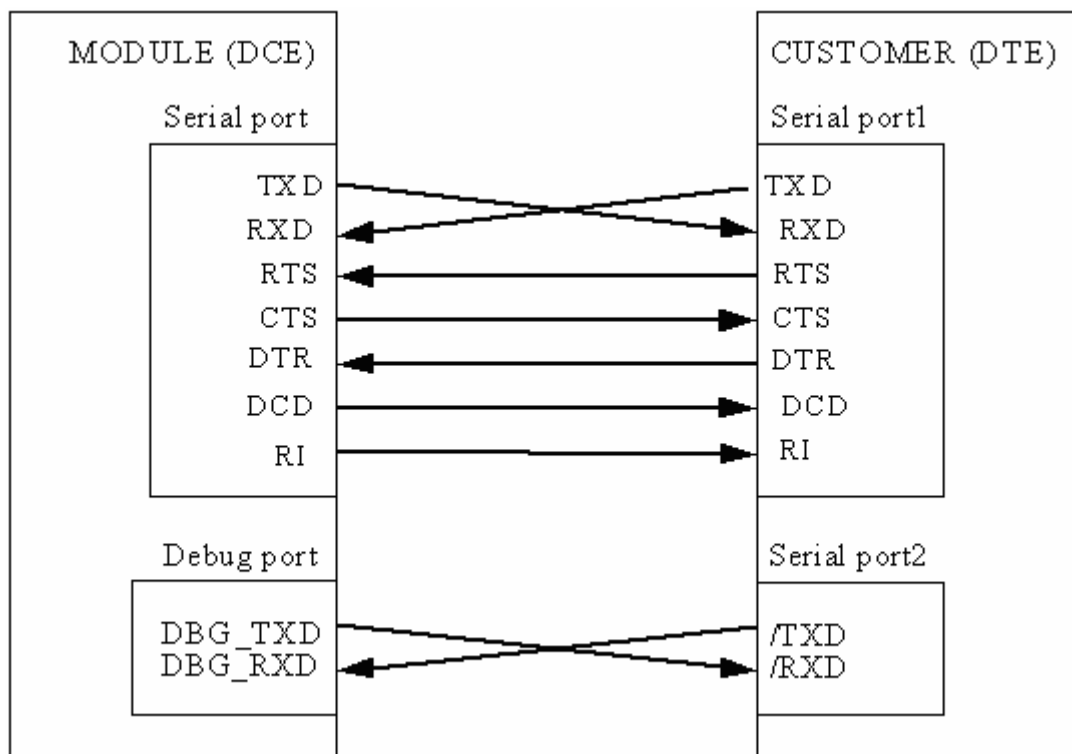

Figure 13: Interface of serial ports

3.9.1 Function of Serial port and Debug port supporting

Serial port

- Seven lines on Serial Port Interface
- Contains Data lines TXD and RXD, State lines RTS and CTS, Control lines DTR, DCD and RING;
- Serial Port can be used for CSD FAX, GPRS service and send AT command of controlling module. Serial Port can use multiplexing function;
- Serial Port supports the communication rate as following:
300, 1200, 2400, 4800, 9600, 19200, 38400, 57600, 115200 Default as 115200bps.
- Autobauding supports the communication rate as following:
1200, 2400, 4800, 9600, 19200, 38400, 57600, and 115200bps.

Autobauding allows the GSM engine to automatically detect the baud rate configured in the host application. The serial interface of the GSM engine supports autobauding for the following baud rates: 1200, 2400, 4800, 9600, 19200, 38400, 57600, 115200. Factory setting is autobauding enabled. This gives you the flexibility to put the GSM engine into operation no matter what bit rate your host application is configured to. To take advantage of autobaud mode specific attention must be paid to the following requirements:

Synchronization between DTE and DCE

When DCE powers on with the autobauding enabled, it is recommended to wait 2 to 3 seconds before sending the first AT character. After receiving the “OK” response, DTE and DCE are correctly synchronized.

Restrictions on autobauding operation

- The serial interface has to be operated at 8 data bits, no parity checkouting and 1 stop bit (factory setting).
- The Unsolicited Result Codes like "RDY", "+CFUN: 1" and "+CPIN: READY" are not indicated when you start up the ME while autobauding is enabled. This is due to the fact that the new baud rate is not detected unless DTE and DCE are correctly synchronized as described above.

Debug port

- Two lines on Serial Port Interface
- Only contains Data lines /TXD and /RXD
- Debug Port only used for debugging. It cannot be used for CSD call, FAX call. And the Debug port can not use multiplexing function;
- Debug port supports the communication rate as following:
9600, 19200, 38400, 57600, 115200bps

Note: You can use AT+IPR=x;&W to set a fixed baud rate and save the configuration to non-volatile flash memory. After the configuration was saved as fixed baud rate, the Unsolicited Result Codes like "RDY" should be received from the serial port all the time when the SIM300 was power on.

3.9.2 Software upgrade and serial Port

The TXD、RXD、DBG_TXD、DBG_RXD、GND must be connected to the IO connector when user need to upgrade software and debug software, the TXD、RXD should be used for software upgrade and the DBG_TXD、DBG_RXD for software debug. The PWRKEY pin is recommended to connect to the IO connector. The user also can add a switch between the PWRKEY and the GND. The PWRKEY should be connected to the GND when SIM300DZ is upgrading software. Please refer to the following figure.

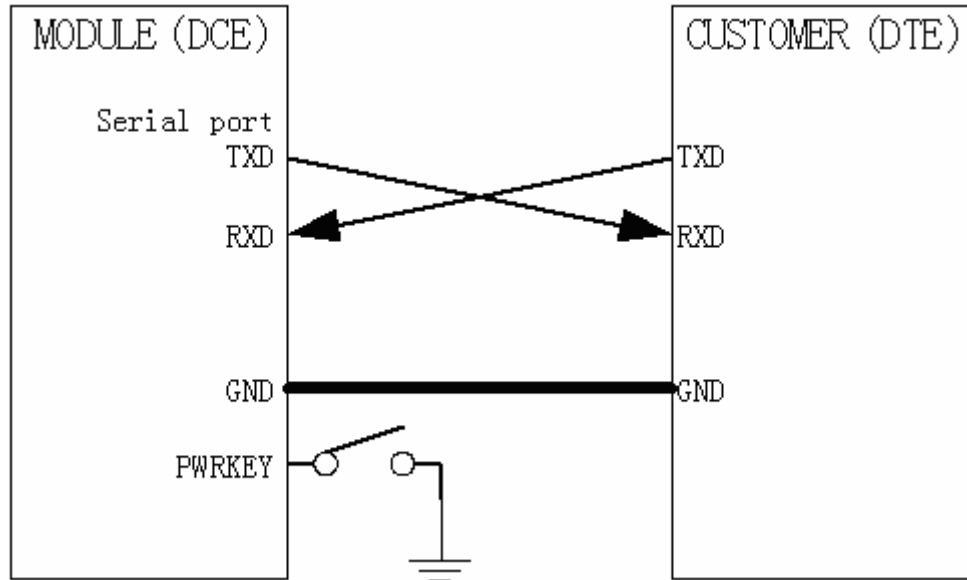

Figure 14: Interface of software upgrade

Note: The RTS PIN must be connected to the GND in the customer circuit when only the TXD and RXD used in the Serial Port communication.

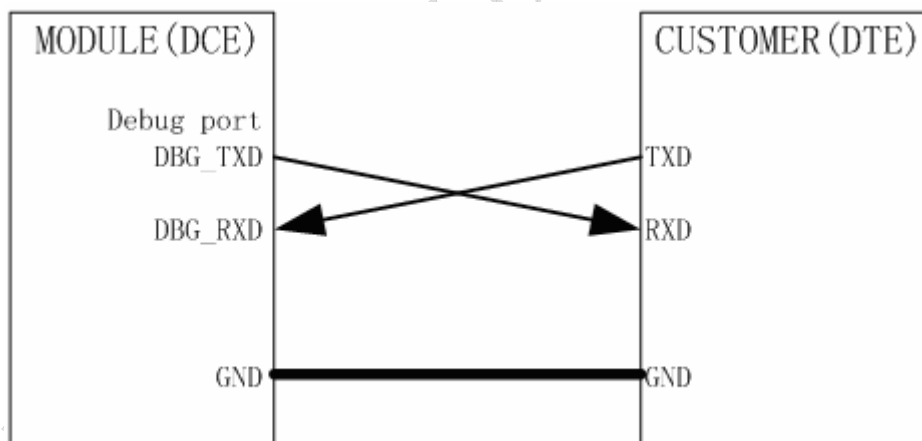

Figure 15: Interface of software debug

Note: The serial port doesn't support the RS_232 level, it only supports the TTL level. You should add the level converter IC between the DCE and DTE, if you connect it to the PC.

3.10 Audio interfaces

Table 13: Audio interface signal

	Name	Pin	Function
(AIN1/AOUT1)	MIC1P	20	Microphone1 input +
	MIC1N	21	Microphone1 input -
	SPK1P	23	Audio1 output+
	SPK1N	24	Audio1 output-
(AIN2/AOUT2)	MIC2P	18	Microphone2 input +
	MIC2N	19	Microphone2 input -
	SPK2P	26	Audio2 output+
	SPK2N	25	Audio2 output-

The module provides two analog input channels, AIN1 and AIN2, which may be used for both microphone and line inputs. The AIN1 and AIN2 channels are identical. One of the two channels is typically used with a microphone built into a handset. The other channel is typically used with an external microphone or external line input. The module analog input configuration is determined by control register settings and established using analog multiplexers.

For each channels, you can use AT+CMIC to set the input gain level of microphone, use AT+ECHO to set the parameters for echo cancellation. Also, you can use AT+SIDET to set the side-tone level. For detail, please refer to *document [1]*.

It is suggested that you adopt the one of following two matching circuits in order to reject common mode noise and audio noise. The difference audio signals have to be layout according to difference signal layout rules.

Notes:

As show in following Figures (Note : all components package are 0603) .BEAD must has low impedance and can be removed according to their environment such as the ground plane, shielding, power lost. The best way is to plan all the components shown in the follow figure. If you want to adopt an amplifier circuit for audio, we commend National company's LM4890. But you can select it according to your needs.

3.10.1 Speaker interface configuration

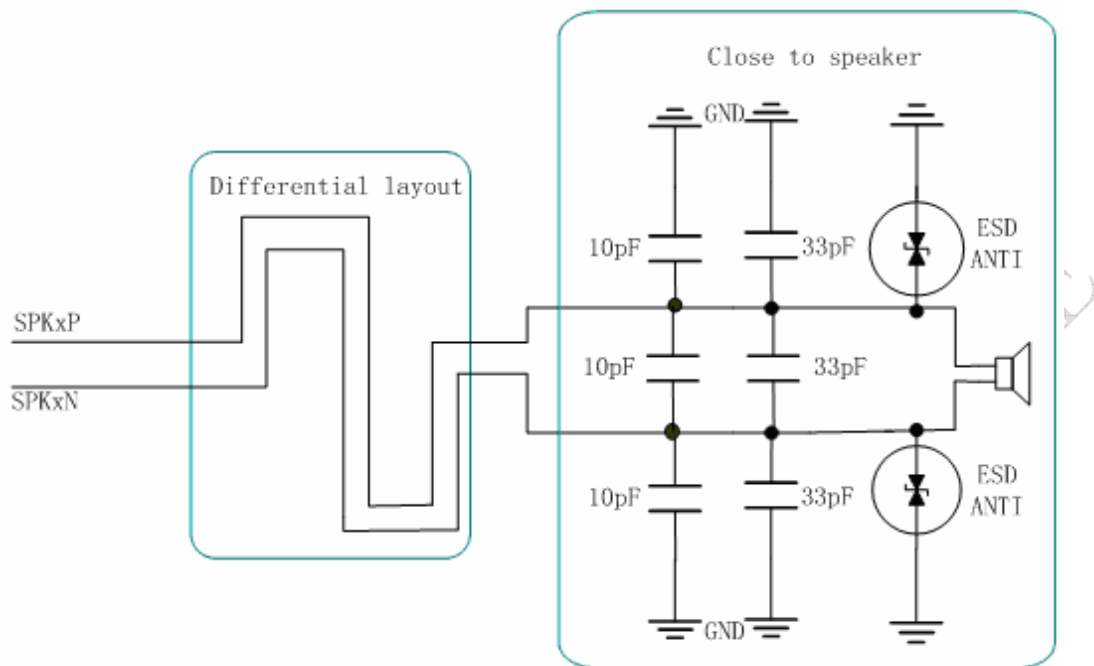

Figure 16: Speaker interface configuration

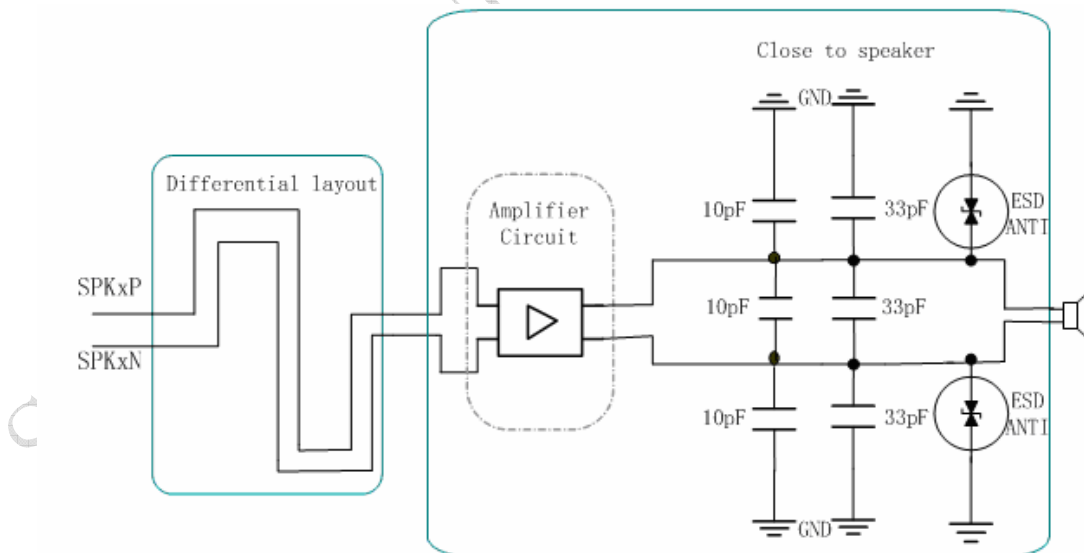

Figure 17: Speaker interface with amplifier configuration

3.10.2 Microphone interfaces configuration

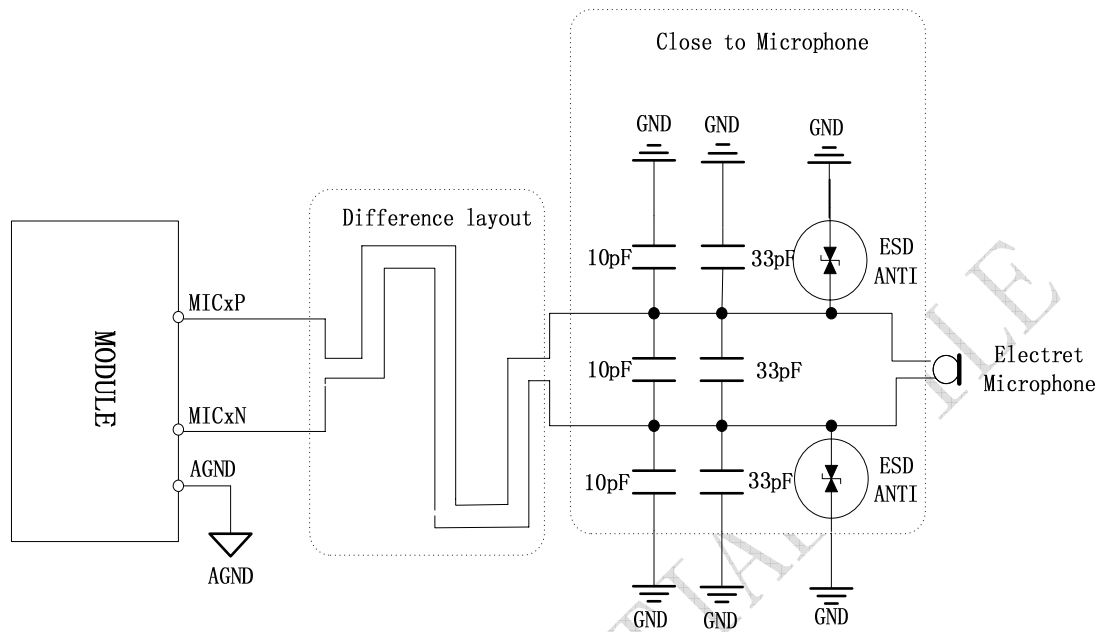

Figure 18: Microphone interface configuration

3.10.3 Earphone interface configuration

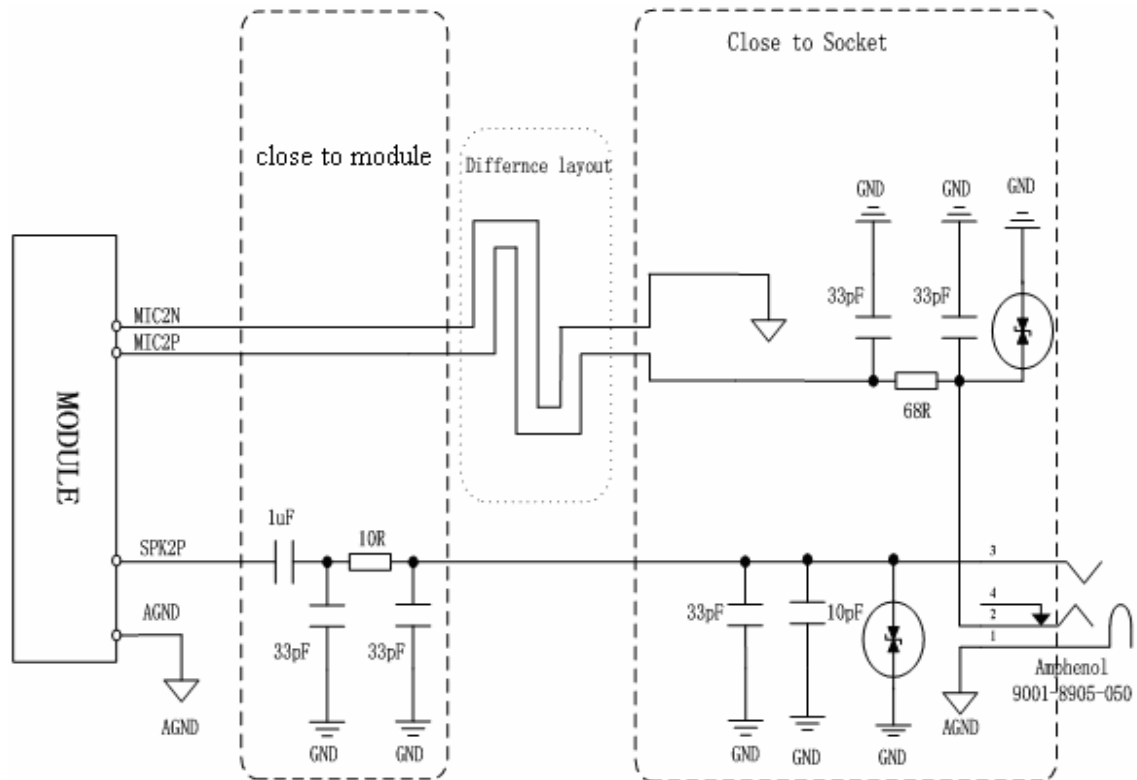

Figure 19: Earphone interface configuration

3.10.4 Referenced electronic characteristic

Table 14: MIC Input Characteristics

Parameter	Min	Typ	Max	Unit
Working Voltage	1.2	1.5	2.0	V
Working Current	300		500	uA
External Microphone Load Resistance	1.2	2.2		k Ohms

Table 15: Audio Output Characteristics

Parameter		Min	Typ	Max	Unit
Normal Output(SPK1)	Single Ended	load Resistance	27	32	Ohm
		Ref level		0.5477 -12.04	V _{pp} dBm
	Differential	load Resistance	27	32	Ohm

SIM300DZ Hardware Design

		Ref level		1.0954 -6.02		Vpp dBm
Auxiliary Output(SPK2)	Single Ended	load Resistance	27	32		Ohm
		Ref level		0.5477 -12.04		Vpp dBm
	Differential	load Resistance	27	32		Ohm
		Ref level		1.0954 -6.02		Vpp dBm

3.11 SIM interface

3.11.1 SIM card application

You can use AT Command to get information in SIM card. For more information, please refer to *document [1]*.

The SIM interface supports the functionality of the GSM Phase 1 specification and also supports the functionality of the new GSM Phase 2+ specification for FAST 64 kbps SIM (intended for use with a SIM application Tool-kit).

Both 1.8V and 3.0V SIM Cards are supported.

The SIM interface is powered from an internal regulator in the module having normal voltage 3V. All pins reset as outputs driving low. Logic levels are as described in table

Table 16: Signal of SIM interface

Pin	Signal	Description
65	SIM_VDD	SIM Card Power supply, it can identify automatically the SIM Card power mode, one is 3.0V±10%, another is 1.8V±10%. Current is about 10mA.
62	SIM_DATA	SIM Card data I/O
63	SIM_CLK	SIM Card Clock
64	SIM_RST	SIM Card Reset

Following is the reference circuit about SIM interface. We recommend an Electro-Static discharge device ST (www.st.com) ESDA6V1W5 or ON SEMI (www.onsemi.com) SMF05C for “ESD ANTI”. The 22Ω resistors showed in the following figure should be added in series on the IO line between the module and the SIM card for protecting the SIM I/O port. The pull up resistor (about

10K Ω) must be added on the SIM_DATA line. Note that the SIM peripheral circuit should be placed close to the SIM card socket.

3.11.2 Design considerations for SIM card holder

The reference circuit about 6 pins SIM card illustrates as following figure.

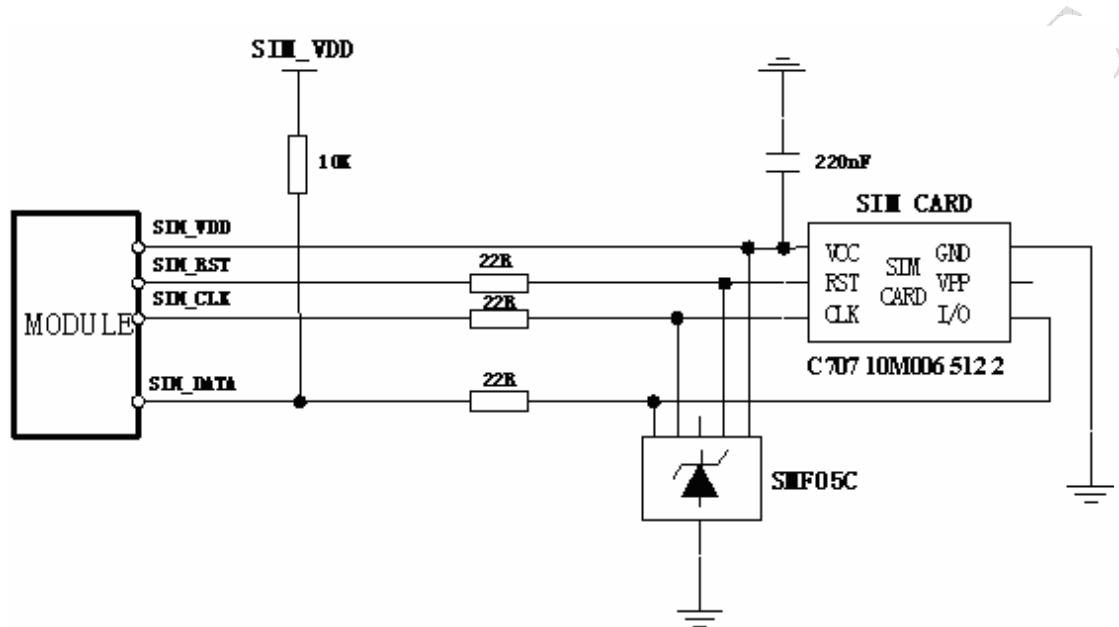

Figure 20: SIM interface reference circuit with 6 pins SIM card

3.12.2 Design considerations for SIM card holder

For 6 pins SIM card, we recommend to use Amphenol C707-10M006 512 2 .You can visit <http://www.amphenol.com> for more information about the holder.

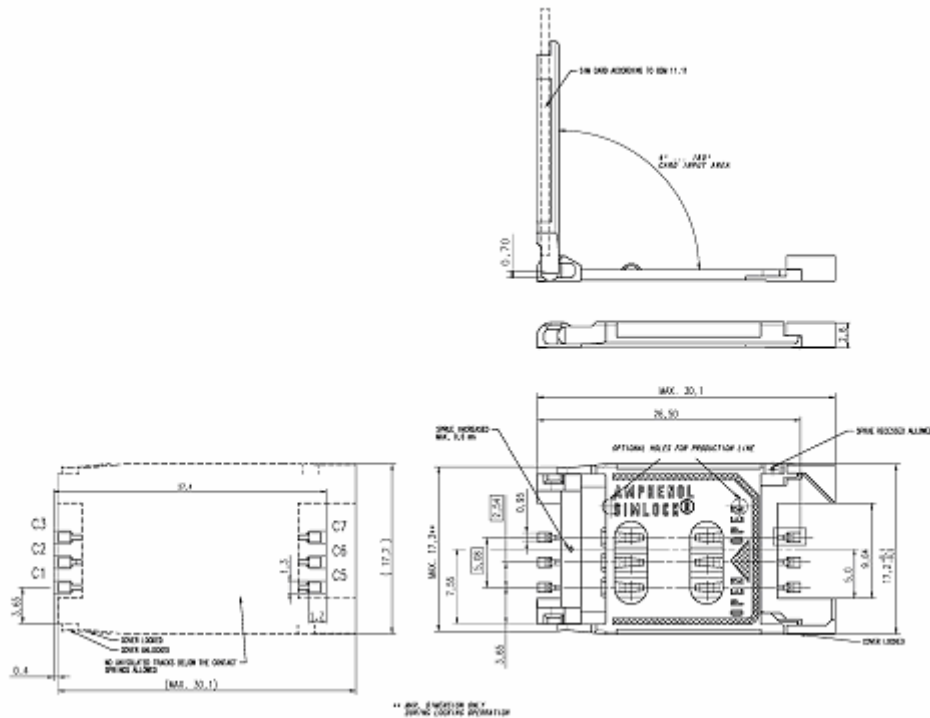

Figure 21: Amphenol C707-10M006 512 2 SIM card holder

Table 17: Pin description (Amphenol SIM card holder)

Pin	Signal	Description
C1	SIM_VDD	SIM Card Power supply, it can identify automatically the SIM Card power mode, one is $3.0V \pm 10\%$, another is $1.8V \pm 10\%$. Current is about 10mA.
C2	SIM_RST	SIM Card Reset.
C3	SIM_CLK	SIM Card Clock.
C5	GND	Connect to GND.
C6	VPP	Not connect.
C7	SIM_DATA	SIM Card data I/O.

Table 18: Pin description (Molex SIM card holder)

Pin	Signal	Description
C1	SIM_VDD	SIM Card Power supply, it can identify automatically the SIM Card power mode, one is $3.0V \pm 10\%$, another is $1.8V \pm 10\%$. Current is about 10mA.
C2	SIM_RST	SIM Card Reset.
C3	SIM_CLK	SIM Card Clock.

SIM300DZ Hardware Design

C4	GND	Connect to GND.
C5	GND	Connect to GND.
C6	VPP	Not connect.
C7	SIM_DATA	SIM Card data I/O.

3.13 General purpose input & output (GPIO)

SIM300DZ provides a limited number of General Purpose Input/Output signal pin.

Table 19: GPO of SIM300DZ

Name	Pin
GPO1	40

SIM300DZ supports one general purpose output signal pin. This pin can be configured through AT command “AT+CGPIO” in users’ application to high voltage level or low voltage level. For detail of this AT command, please refer to *document [1]*.

3.14 ADC

SIM300DZ provide two auxiliary ADC (General purpose analog to digital converter.) as voltage input pin, which can be used to detect the values of some external items such as voltage, temperature etc. User can use AT command “AT+RADC” to read the voltage value added on ADC pin. For detail of this AT command, please refer to [1].

Table 20: ADC pin of SIM300DZ

Name	Pin	Input voltage scope(V)
ADC0	29	0 – 2.4

3.15 Behaviors of the RI line (Serial port1 interface only)

Table 21: Behaviours of the RI line

State	RI respond
Standby	HIGH

SIM300DZ Hardware Design

Voice calling	Change LOW, then: (1) Change to HIGH when establish calling. (2) Use AT command ATH the RING hold LOW. (3) Sender hang up, change to HIGH
Data calling	Change LOW, then: (1) Change to HIGH when establish calling. (2) Use AT command ATH , the RI change to HIGH.
SMS	When receive SMS, The RI will change to Low and hold low level about 120 ms, then change to HIGH.

If the module is used as caller, signal RI will maintain high. But when it is used as receiver, following is timing of RI.

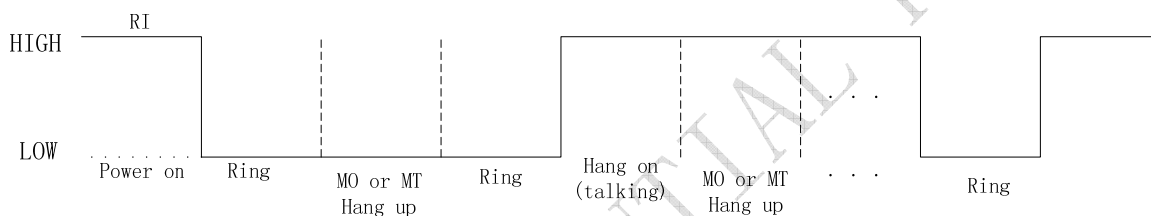

Figure 22: SIM300DZ Services as Receiver

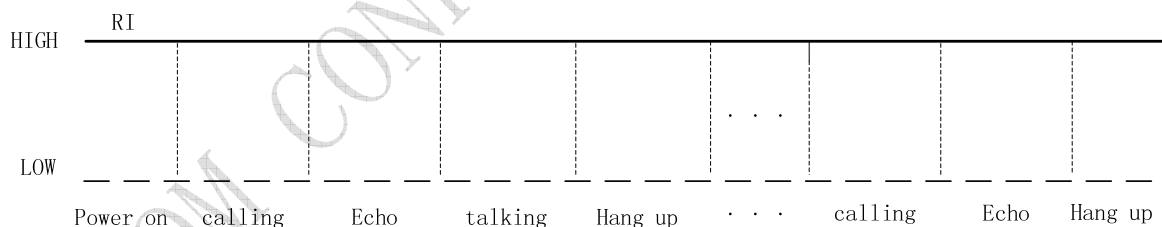

Figure 23: SIM300DZ Services as caller

3.16 Network status indication LED lamp

The NETLIGHT (PIN 41) can be used to drive a network status indication LED lamp. The working state of this pin is listed in table22:

Table 22: Working state of network status indication LED pin

State	SIM300DZ function
Off	SIM300DZ is not running
64ms On/ 800ms +50%Off	SIM300DZ does not find the network
64ms On/ 3000ms +50%Off	SIM300DZ find the network
64ms On/ 300ms +50%Off	GPRS communication

We provide a reference circuitry for you, shown as figure24:

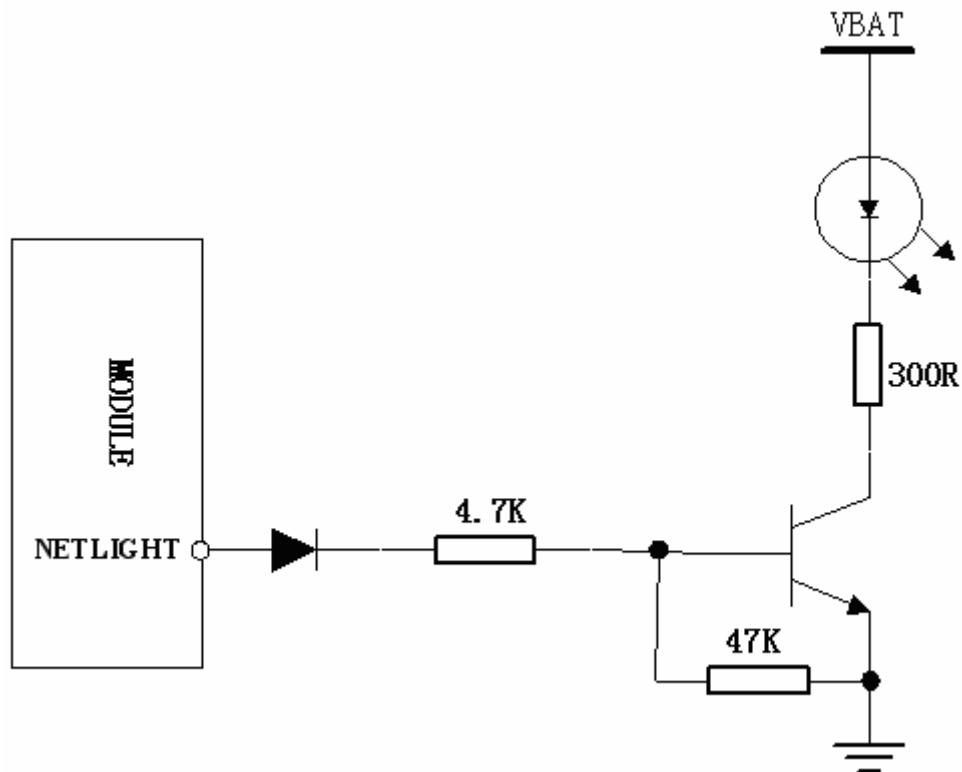
**Figure 24: Reference circuit for Network status LED**

4 Antenna interface

- The pin 33 is the RF antenna pad. The RF interface has an impedance of 50Ω.

4.1 Antenna installation

4.1.1 Antenna pad

SIM300DZ provides RF antenna interface. And customer's antenna should be located in the customer's mainboard and connect to module's antenna pad through microstrip line or other type RF trace which impedance must be controlled in 50Ω. To help you to ground the antenna, SIM300DZ comes with a grounding plane located close to the antenna pad. The antenna pad of SIM300DZ is shown as figure 25(right):

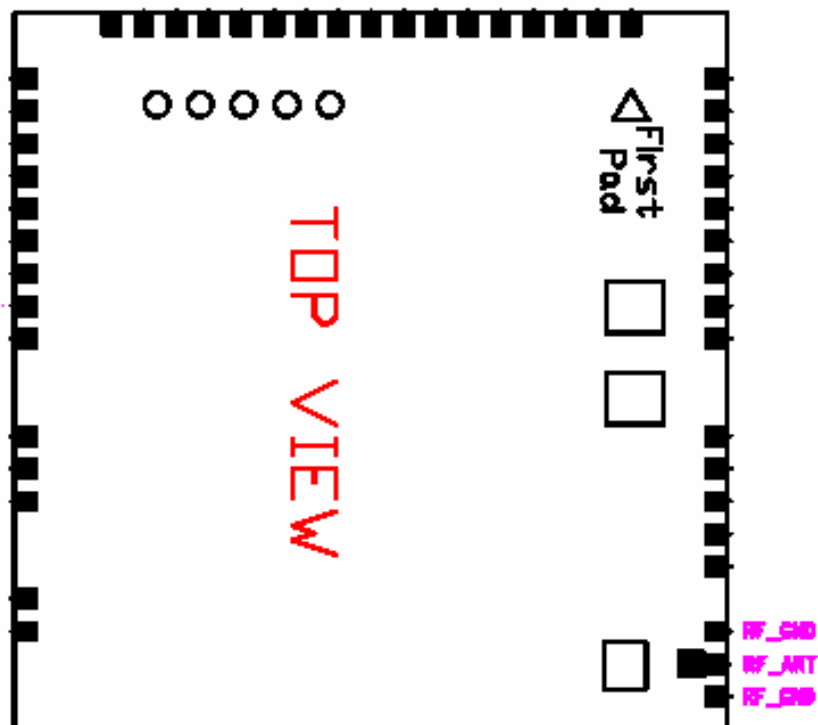

Figure 25: RF pad

SIM300DZ material properties:

SIM300DZ PCB Material: FR4

Antenna pad: Gold plated pad

4.2 Module RF output power

Table 23: SIM300DZ conducted RF output power

Frequency	Max	Min
EGSM900	33dBm ±2db	5dBm±5db
DCS1800	30dBm ±2db	0dBm±5db
PCS1900	30dBm ±2db	0dBm±5db

4.3 Module RF receive sensitivity

Table 24: SIM300DZ conducted RF receive sensitivity

Frequency	Receive sensitivity
EGSM900	< -106dBm
DCS1800	< -106dBm
PCS1900	< -106dBm

4.4 Module operating frequencies

Table 25: SIM300DZ operating frequencies

Frequency	Receive	Transmit
EGSM900	925 ~ 960MHz	880 ~ 915MHz
DCS1800	1805 ~ 1880MHz	1710 ~ 1785MHz
PCS1900	1930 ~ 1990MHz	1850 ~ 1910MHz

5 Electrical, reliability and radio characteristics

5.1 Absolute maximum ratings

Absolute maximum rating for power supply and voltage on digital and analog pins of SIM300DZ are list in table26:

Table 26: Absolute maximum rating

Parameter	Min	Max	Unit
Peak current of power supply	0	4.0	A
RMS current of power supply (during one TDMA- frame)	0	0.7	A
Voltage at digit pins	-0.3	3.3	V
Voltage at analog pins	-0.3	3.0	V
Voltage at digit/analog pins in POWER DOWN mode	-0.25	0.25	V

5.2 Operating temperatures

The operating temperature is listed in table26:

Table 27: SIM300DZ operating temperature

Parameter	Min	Typ	Max	Unit
Ambient temperature	-20	25	55	°C
Restricted operation*	-30 to -20		55 to 80	°C
Storage temperature	-40		+85	°C

* SIM300DZ can work, but the deviation from the GSM specification may occur.

5.3 Power supply rating

Table 28: SIM300DZ power supply rating

Parameter	Description	Conditions	Min	Typ	Max	Unit
VBAT	Supply voltage	Voltage must stay within the min/max values, including voltage drop, ripple, and spikes.	3.4	4.0	4.5	V
	Voltage drop during transmit burst	Normal condition, power control level for Pout max			400	mV

SIM300DZ Hardware Design

	Voltage ripple	Normal condition, power control level for Pout max @ f<200kHz @ f>200kHz			50 2	mV
IVBAT	Average supply current)	POWER DOWN mode SLEEP mode (BS-PA-MFRMS=5)		45 2.5		uA mA
		IDLE mode EGSM 900 DCS1800/PCS1900		18.7 18		mA
		TALK mode EGSM 900 DCS1800/PCS1900		250 184		mA
		DATA mode GPRS, (3 Rx, 2 TX) EGSM 900 DCS1800/PCS1900		436 350		mA
		DATA mode GPRS, (4 Rx, 1 TX) EGSM 900 DCS1800/PCS1900		245 180		mA
	Peak supply current (during transmission slot every 4.6ms)	Power control level for Pout max.		2	3	A

5.4 Current consumption

The values for current consumption listed below refer to Table 28.

Table 29: SIM300DZ current consumption

Voice Call	
EGSM 900	@power level #5 <350mA, Typical 260mA @power level #10, Typical 130mA @power level #19, Typical 86mA
DCS1800/PCS1900	@power level #0 <300mA, Typical 200mA @power level #10, Typical 87mA @power level #15, Typical 80mA
GPRS Data	
DATA mode, GPRS (1 Rx, 1 Tx) CLASS 8	
EGSM 900	@power level #5 <350mA, Typical 260mA @power level #10, Typical 125mA

SIM300DZ Hardware Design

	@power level #19, Typical 84mA
DCS1800/PCS1900	@power level #0 <300mA, Typical 200mA @power level #10, Typical 83mA @power level #15, Typical 76mA
DATA mode, GPRS (3 Rx, 2 Tx) CLASS 10	
EGSM 900	@power level #5 <550mA, Typical 470mA @power level #10, Typical 225mA @power level #19, Typical 142mA
DCS1800/PCS1900	@power level #0 <450mA, Typical 340mA @power level #10, Typical 140mA @power level #15, Typical 127mA
DATA mode, GPRS (4 Rx, 1 Tx) CLASS 8	
EGSM 900	@power level #5 <350mA, Typical 270mA @power level #10, Typical 160mA @power level #19, Typical 120mA
DCS1800/PCS1900	@power level #0 <300mA, Typical 220mA @power level #10, Typical 120mA @power level #15, Typical 113mA

Class 10 is default set when the module work at data translation mode, the module can also work at class 8 set by AT command.

5.5 Electro-Static discharge

The GSM engine is not protected against Electrostatic Discharge (ESD) in general. Therefore, it is subject to ESD handling precautions that typically apply to ESD sensitive components. Proper ESD handling and packaging procedures must be applied throughout the processing, handling and operation of any application using a SIM300DZ module.

The measured values of SIM300DZ are shown as the following table:

Table 30: The ESD endure statue measured table (Temperature: 25°C, Humidity:45%)

Part	Contact discharge	Air discharge
VBAT,GND	±4KV	±8KV
KBR0-4, DTR, RXD, TXD, RTS, DISP_DATA, DISP_CLK	±2KV	±4KV
Antenna port	±2KV	±4KV
Other port	±1KV	

6 Mechanics

This chapter describes the mechanical dimensions of SIM300DZ.

6.1 Mechanical dimensions of SIM300DZ

Following shows the Mechanical dimensions of SIM300D (top view, side view and bottom view).

Dimensions shown in millimeters

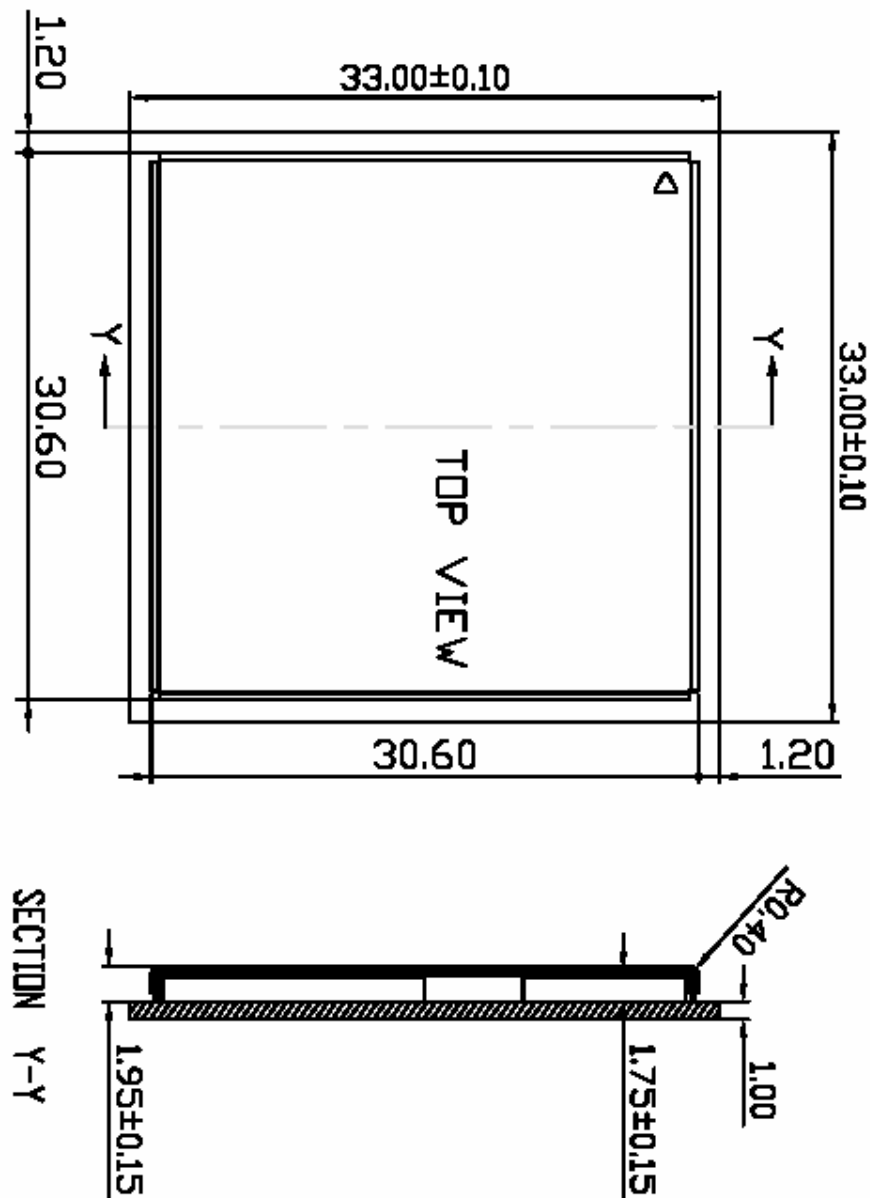

Figure 26: SIM300DZ TOP view and SIDE view

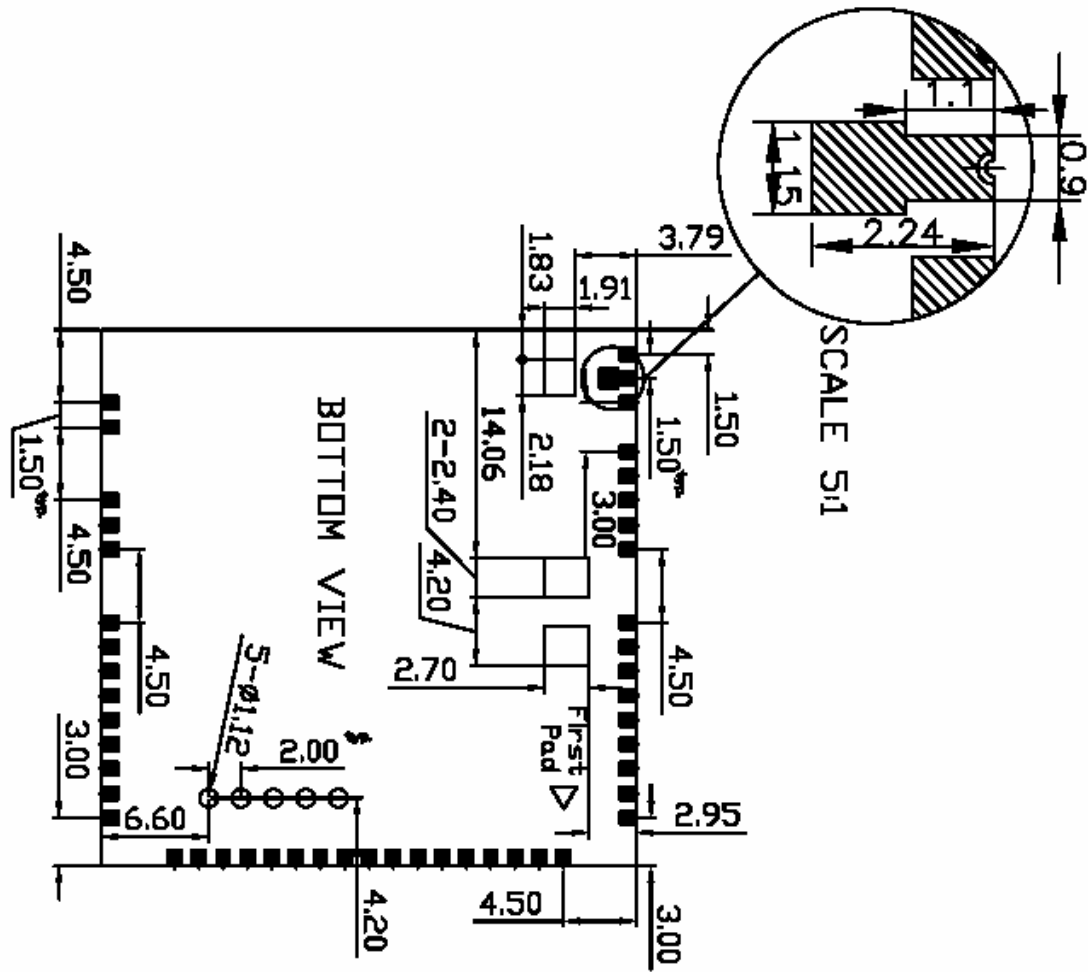

Figure 27: SIM300DZ bottom view

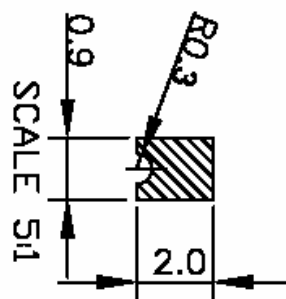

Figure 28: PAD BOTTOM VIEW

FOOT PRINT RECOMMENDATION

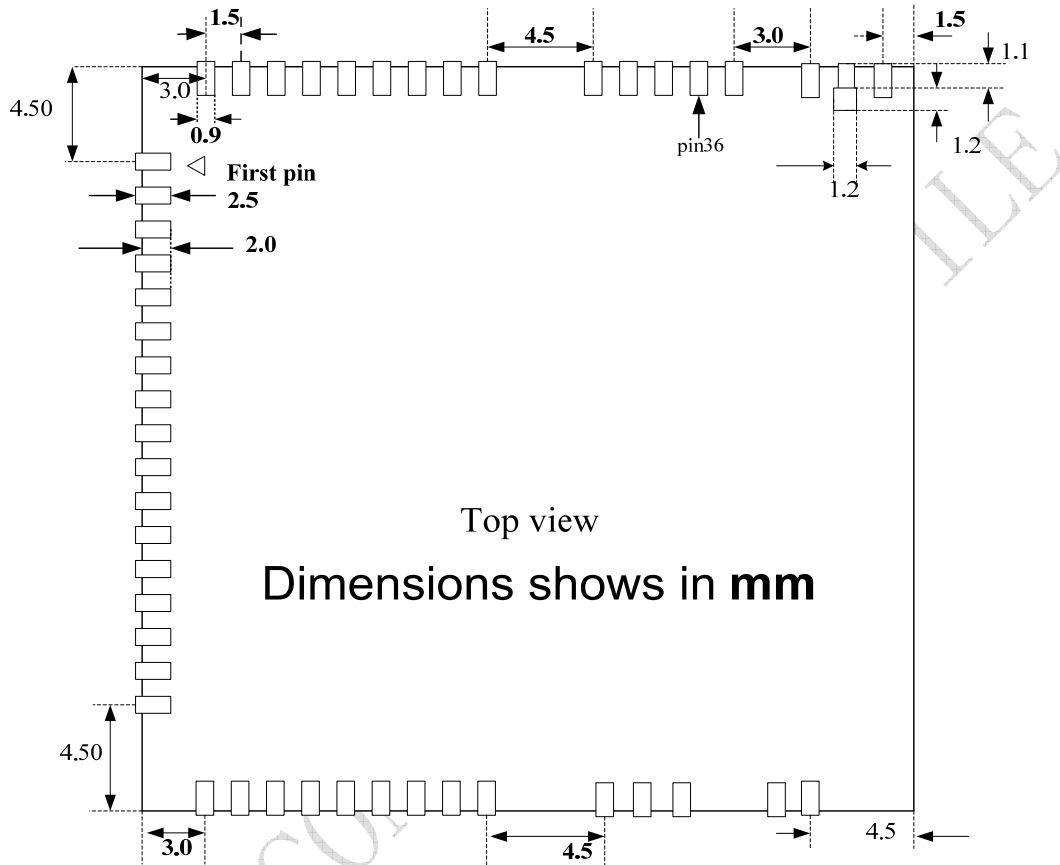

Figure 29: Footprint recommendation

6.2 PIN assignment of SIM300DZ

Table 29: PIN assignment

Pin NUM	NAME	Pin NUM	NAME
1	DBG_RXD	36	GND
2	DBG_TXD	37	GND
3	RXD	38	VBAT
4	TXD	39	VBAT
5	STATUS	40	GPO1
6	SIM_DATA	41	NETLIGHT
7	SIM_CLK	42	DCD
8	SIM_RST	43	DTR
9	SIM_VDD	44	RTS
10	KBR0	45	CTS
11	RI	46	DISP_CS
12	PWRKEY	47	NC
13	DISP_CLK	48	GND
14	DISP_DATA		
15	VRTC		
16	DISP_D/C		
17	GND		
18	MIC2P		
19	MIC2N		
20	MIC1N		
21	MIC1P		
22	AGND		
23	SPK1P		
24	SPK1N		
25	SPK2N		
26	SPK2P		
27	TEMP_BAT		
28	VCHG		
29	ADC0		
30	GND		
31	GND		
32	GND		
33	ANTENNA		
34	GND		

NOTE: If any pin you would not use in your application design, it is recommended that leave the relative pad empty in your main board.



Figure 30: Physical SIM300DZ



Figure 31: Bottom view of SIM300DZ

6.3 The ramp-soak-spike reflow profile of SIM300DZ

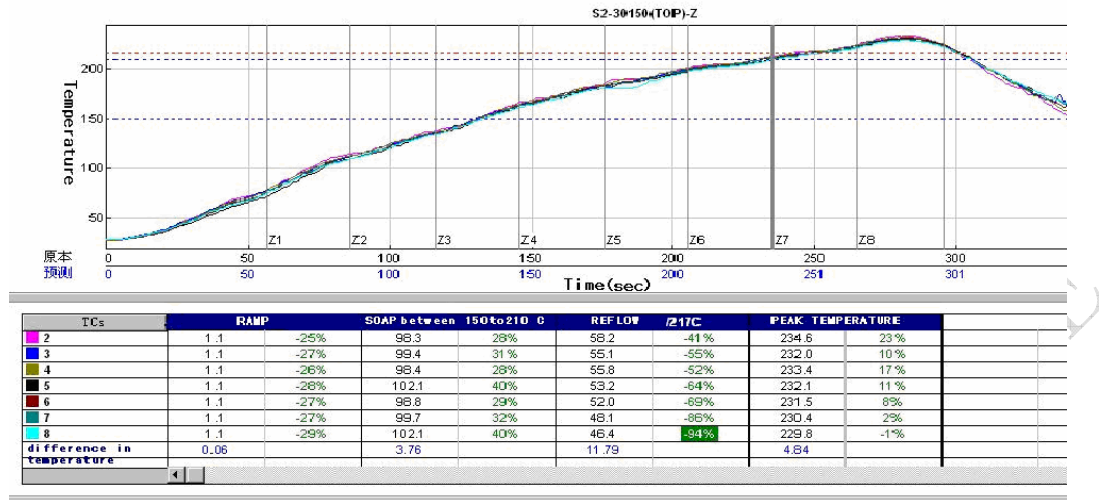

Figure 32: The ramp-soak-spike reflow profile of SIM300DZ

Contact us:

Shanghai SIMCom Ltd.

Add: SIM Technology Building, No. 700, Yishan Road, Shanghai, P. R. China 200233

Tel: +86 21 5427 8900

Fax: +86 21 5427 6035

URL: www.sim.com

SIMCOM CONFIDENTIAL FILE