

未注公差/General tolerances(mm)	0	>3	>6	>10	>18	>30	>50	>80	>120	>180	>250	>315	>400	>500	0.1/10
	~	~	~	~	~	~	~	~	~	~	~	~	~	~	±2
	+0.12	+0.18	+0.22	+0.26	+0.31	+0.37	+0.57	+0.80	+0.93	+1.05	+1.15	+1.60	+2.20	±2.50	

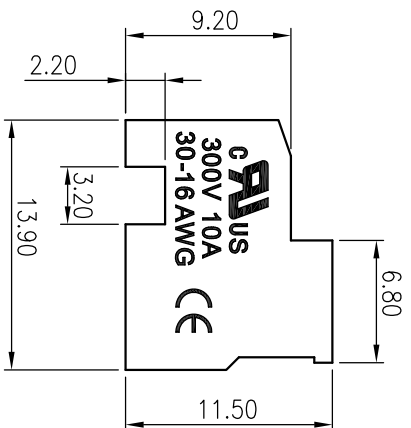
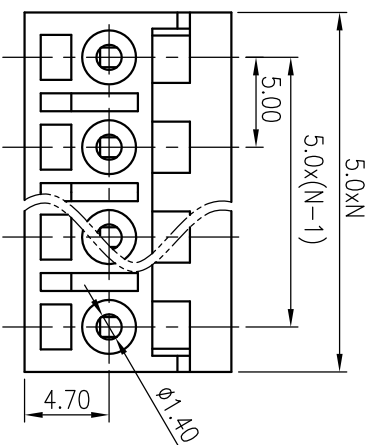
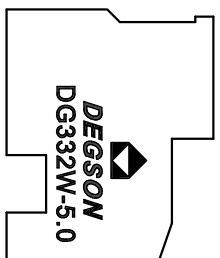
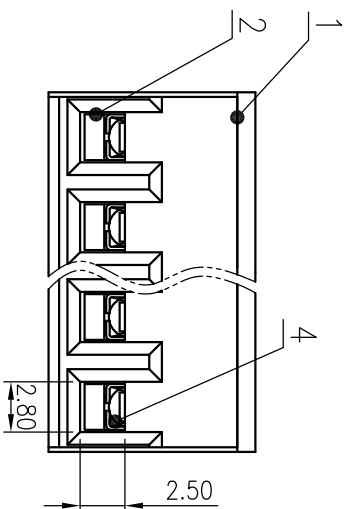
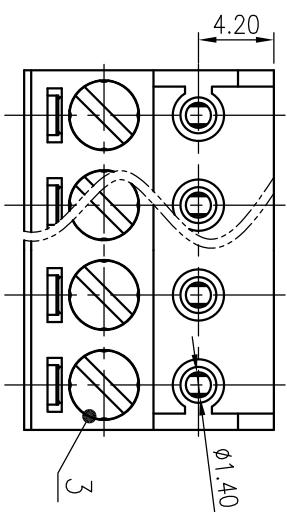

UL 标准/UL Standard:	B	C	D
额定电压/Rated Voltage(V)	300/10		300/10
EC 标准/EC Standard:			
过压类别/Overvoltage Category/污染等级/Pollution Degree	III/3	III/2	II/2
额定电压/电流/Rated Voltage(V)/Current(A)		250/12	
工频耐压/Withstanding voltage(V/1Min)			AC2000
螺丝扭矩/Torque Tightening(N·m/Lb·in)			M2.5, 0.4/3.54
线径范围(硬线和软线)/Wire Range(rigid and flexible)(mm² AWG)			0.2~1.5/30~16
间距/Pitch(mm)/线数范围/Poles		5.0/N=02~12P	
剥线长度/Stripping length(mm)			5-6.5
使用温度范围/Operating temperature(°C)			-40~+105
符合RoHS环保要求/Conform to RoHS			Yes

MATERIAL:

MAT NO: /

STATUS: /

APPD:lan CHH 2020.05.21

CHKD:Yu JZh 2020.05.21

DRT: Wu LF 2020.05.21

NAME: **DEGSON** 宁波高松电子有限公司  
NINGBO DEGSON ELECTRICAL CO., LTD

DG332W-5.0-XXP-1Y-00A(H)

DRAWING NO.: 10002131

TYPE: CUSTOMER DRAWING SCALE: 2.5:1 SHEET 1/1

4	Clamp	Copper alloy	Sn plated
3	Screw	Steel	M2.5/Zn plated
2	Cage	Copper alloy	M2.5/Ni plated
1	Housing	PA66	UL94V-0
ITEM	NAME OF PART	MATERIAL	NOTES

REV	ECN	DESCRIPTION	DRT	DATE

1	2	3	4	5	6
---	---	---	---	---	---