

8channel source type DMOS transistor array

62783 series are DMOS transistor array with 8 circuits. It has a clamp diode for switching inductive loads built-in in each output. Please be careful about thermal conditions during use.

Features

- 8 circuits built-in
- High voltage : $V_{OUT} = 50\text{ V (MAX)}$
- High current : $I_{OUT} = -500\text{ mA}$
(MAX for each channel)
- Input voltage(output on): 2.0 V (MIN)
- Input voltage(output off): 0.6 V (MAX)

Pin connection (top view)

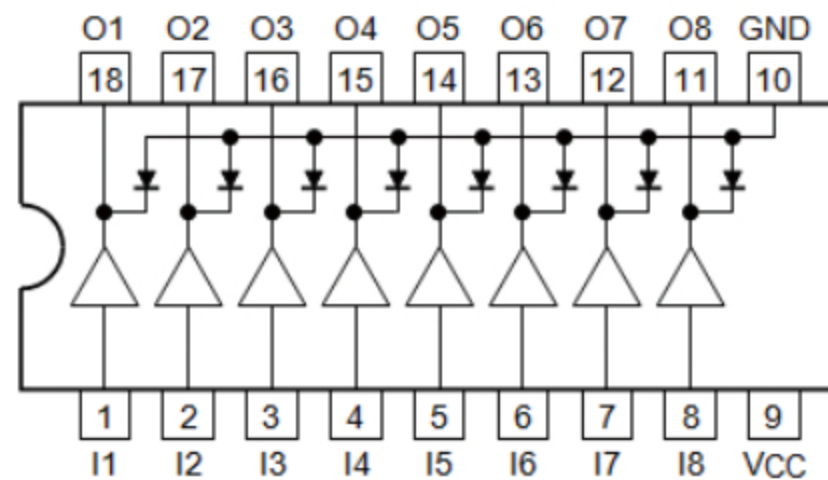

Pin connection may be simplified for explanatory purpose.

Pin explanations

Pin No.	Pin name	Function
1	I1	Input pin
2	I2	Input pin
3	I3	Input pin
4	I4	Input pin
5	I5	Input pin
6	I6	Input pin
7	I7	Input pin
8	I8	Input pin
9	VCC	Power supply pin
10	GND	GND pin
11	O8	Output pin
12	O7	Output pin
13	O6	Output pin
14	O5	Output pin
15	O4	Output pin
16	O3	Output pin
17	O2	Output pin
18	O1	Output pin

Equivalent circuit (each driver)

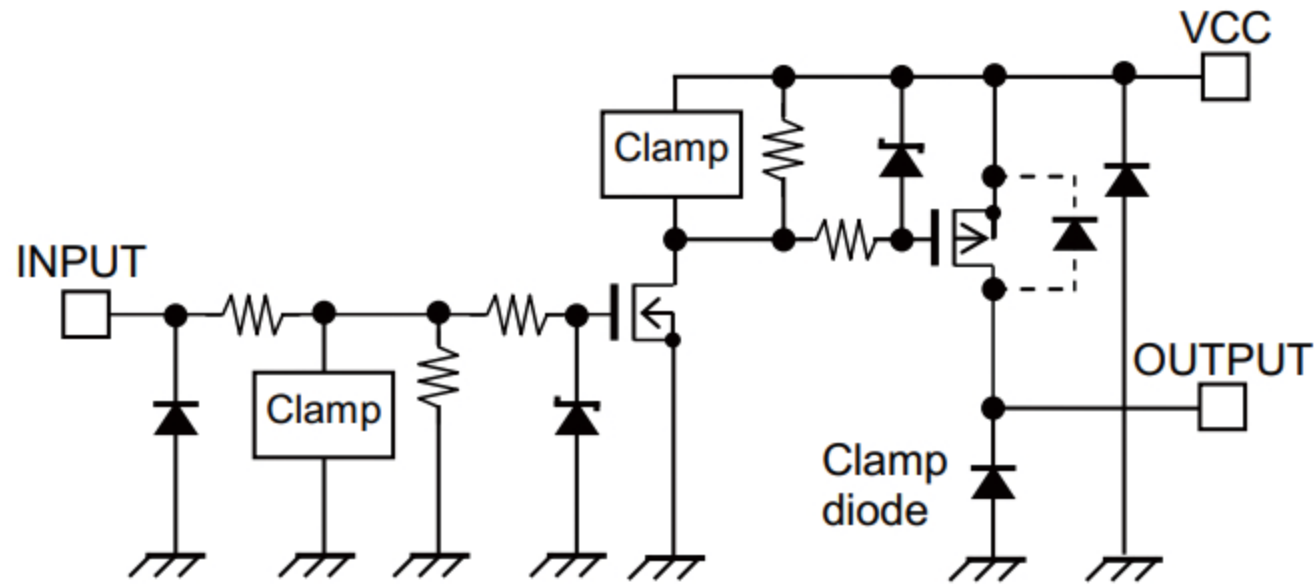

Equivalent circuit may be simplified for explanatory purpose.

Absolute Maximum Ratings (Ta = 25°C)

Characteristics	Symbol	Rating	Unit
Power supply voltage	V _{CC}	-0.5 to 50	V
Output current (for each channel)	I _{OUT}	-500	mA
Input voltage	V _{IN}	-0.5 to 30	V
Clamp diode reverse voltage	V _R	50	V
Clamp diode forward current	I _F	500	mA
Power dissipation	PG (Note1)	1.47	W
	FG (Note2)	0.96	
	FNG (Note3)	0.96	
	FWG (Note4)	1.31	
Operating temperature	T _{opr}	-40 to 85	°C
Storage temperature	T _{stg}	-55 to 150	°C

Note1: Device alone. When Ta exceeds 25°C, it is necessary to do the derating with 11.8 mW/°C.

Note2: Device alone. When Ta exceeds 25°C, it is necessary to do the derating with 7.7 mW/°C.

Note3: On PCB (Size: 50 mm × 50 mm × 1.6 mm, Cu area: 40%, single-side glass epoxy).
When Ta exceeds 25°C, it is necessary to do the derating with 7.7 mW/°C.

Note4: On PCB (Size: 75 mm × 114 mm × 1.6 mm, Cu area: 20%, single-side glass epoxy).
When Ta exceeds 25°C, it is necessary to do the derating with 10.48 mW/°C.

Operating Ranges (Ta = -40 to 85°C)

Characteristics	Symbol	Condition	Min	Typ.	Max	Unit
Power supply voltage	V _{CC}	I _{OUT} = -100 mA	2.0	—	50	V
Output current (for each channel)	PG (Note1)	1 circuits ON, Ta = 25°C	0	—	-400	mA
		t _{pw} = 25 ms 8 circuits ON Ta = 85°C T _j = 120°C	Duty = 10%	0	—	
	Duty = 50%		0	—	-170	
	FG (Note1)	1 circuits ON, Ta = 25°C	0	—	-400	
		t _{pw} = 25 ms 8 circuits ON Ta = 85°C T _j = 120°C	Duty = 10%	0	—	
	Duty = 50%		0	—	-140	
	FNG (Note2)	1 circuits ON, Ta = 25°C	0	—	-400	
		t _{pw} = 25 ms 8 circuits ON Ta = 85°C T _j = 120°C	Duty = 10%	0	—	
	Duty = 50%		0	—	-140	
	FWG (Note3)	1 circuits ON, Ta = 25°C	0	—	-400	
		t _{pw} = 25 ms 8 circuits ON Ta = 85°C T _j = 120°C	Duty = 10%	0	—	
	Duty = 50%		0	—	-160	
Input voltage (Output on)	V _{IN (ON)}	I _{OUT} = -100 mA or upper, V _{DS} = 2.0 V	2.0	—	25	V
Input voltage (Output off)	V _{IN (OFF)}	I _{OUT} = -100 μA or less, V _{DS} = 2.0 V	0	—	0.6	V
Clamp diode forward current	I _F	—	—	—	400	mA

Electrical Characteristics (Ta = 25°C unless otherwise noted)

Characteristics	Symbol	Test Circuit	Condition	Min	Typ.	Max	Unit
Output leakage current	I_{leak}	1	$V_{CC} = 50\text{ V}$, $V_{IN} = 0\text{ V}$ $T_a = 85^\circ\text{C}$	—	—	1.0	μA
Output voltage (Output ON-resistance)	V_{DS} (R_{ON})	2	$I_{OUT} = -350\text{ mA}$ $V_{IN} = 5.0\text{ V}$, $V_{CC} = 5.0\text{ V}$	—	0.56 (1.6)	1.14 (3.25)	V (Ω)
			$I_{OUT} = -200\text{ mA}$ $V_{IN} = 5.0\text{ V}$, $V_{CC} = 5.0\text{ V}$	—	0.32 (1.6)	0.65 (3.25)	
			$I_{OUT} = -100\text{ mA}$ $V_{IN} = 5.0\text{ V}$, $V_{CC} = 5.0\text{ V}$	—	0.16 (1.6)	0.325 (3.25)	
Input current (Output on)	$I_{IN (ON)}$	3	$V_{IN} = 2.0\text{ V}$	—	—	0.1	mA
Input current (Output off)	$I_{IN (OFF)}$	4	$V_{IN} = 0\text{ V}$, $T_a = 85^\circ\text{C}$	—	—	1.0	μA
Input voltage (Output on)	$V_{IN (ON)}$	5	$I_{OUT} = -100\text{ mA}$ or upper $V_{DS} = 2.0\text{ V}$	—	—	2.0	V
Supply current (for each channel)	I_{CC}	3	$V_{IN} = 2.0\text{ V}$, $V_{CC} = 50\text{ V}$ Output open	—	—	1.5	mA
Clamp diode reverse current	I_R	6	$V_R = 50\text{ V}$, $T_a = 85^\circ\text{C}$	—	—	1.0	μA
Clamp diode forward voltage	V_F	7	$I_F = 350\text{ mA}$	—	—	2.0	V
Turn-on delay	t_{ON}	8	$V_{CC} = 50\text{ V}$ $R_L = 125\ \Omega$ $C_L = 15\text{ pF}$	—	0.4	—	μs
Turn-off delay	t_{OFF}			—	2.0	—	

Test circuit

1. I_{leak}

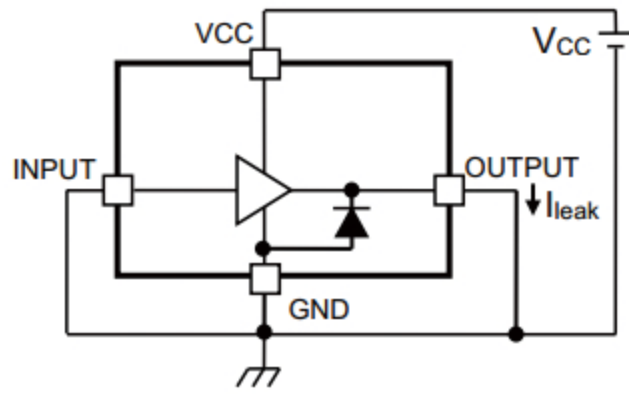

2. $V_{DS} (R_{ON})$

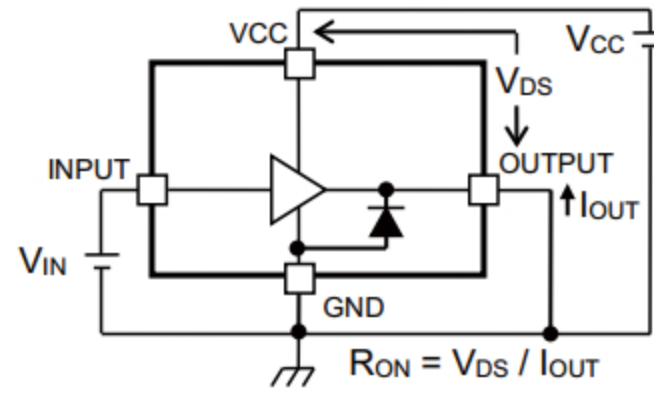

3. $I_{IN} (ON), I_{CC}$

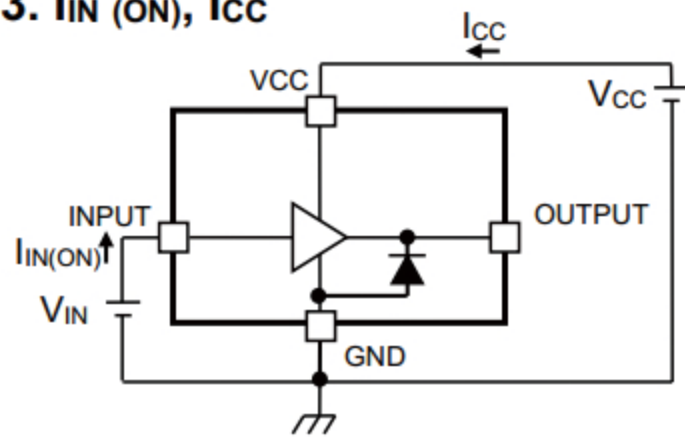

4. $I_{IN} (OFF)$

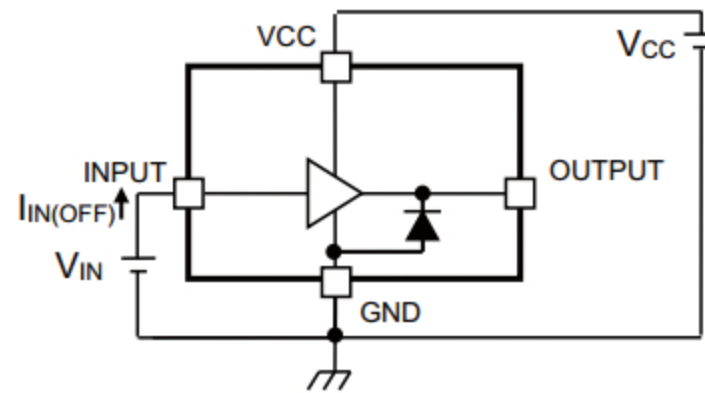

5. $V_{IN} (ON)$

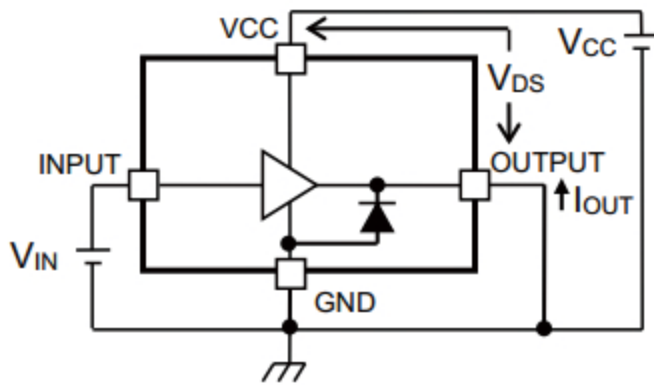

6. I_R

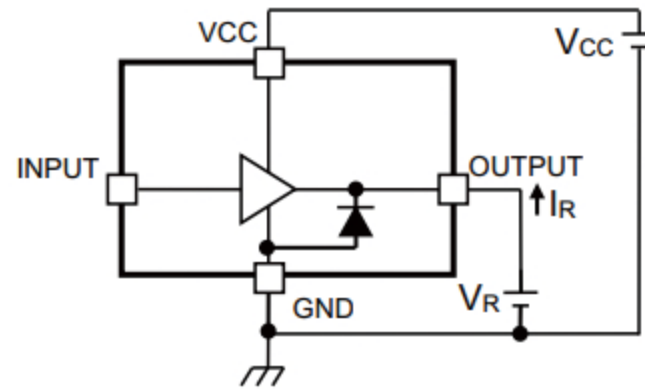

7. V_F

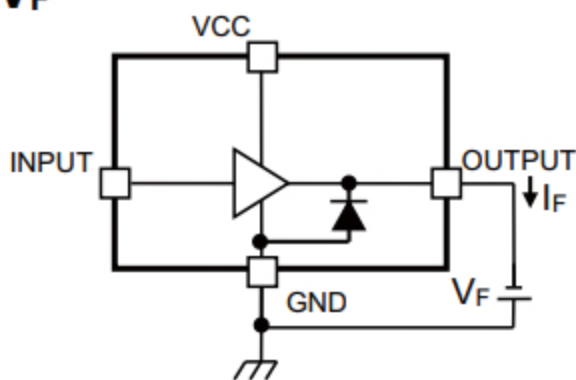

Test circuit may be simplified for explanatory purpose.

8. t_{ON}, t_{OFF}

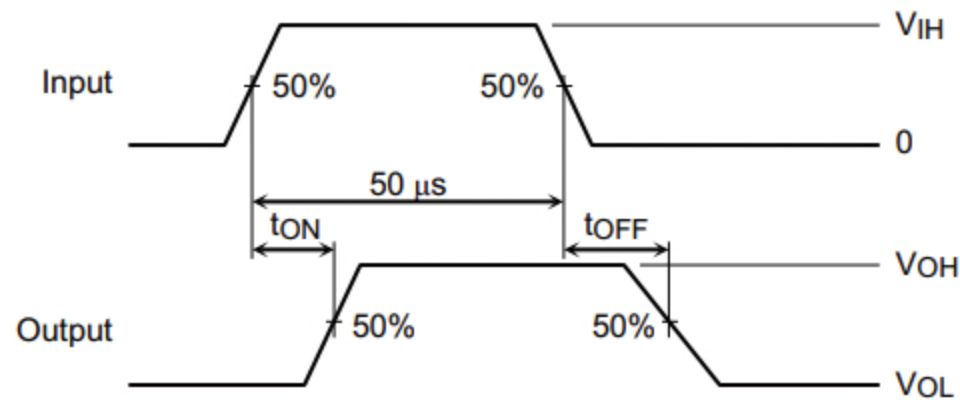
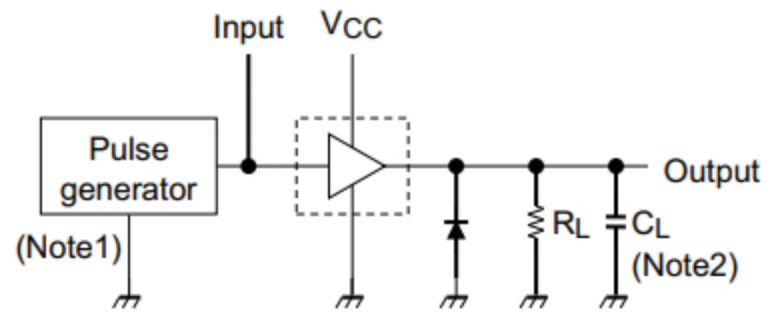

Note 1: Pulse width 50 μs, Duty cycle 10%

Output impedance 50 Ω, t_r ≤ 5 ns, t_f ≤ 10 ns, V_{IH} = 5.0 V

Note 2: C_L includes the probe and the test board capacitance.

Test circuit and timing chart may be simplified for explanatory purpose.

Precautions for Using

This IC does not include built-in protection circuits for excess current or overvoltage. Therefore, if the short-circuit between adjacent pins or between outputs, the short-to-power or ground fault has occurred, the current or voltage beyond the absolute maximum rating is impressed, and IC destroys. When designing, please consider enough in power supply line, output line and GND line. In addition, so as not to continue to flow a current that exceeds the absolute maximum rating of the IC, please insert the appropriate fuse in the power supply line.

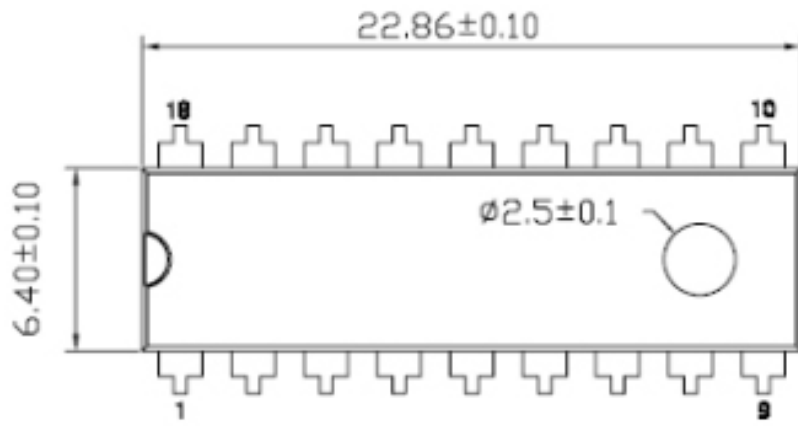

DIP

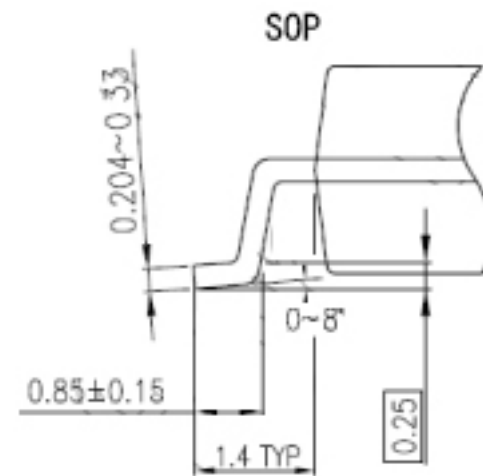
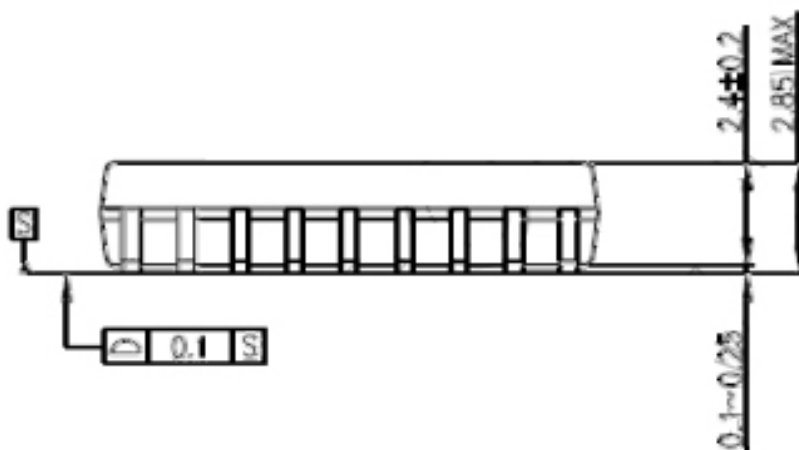
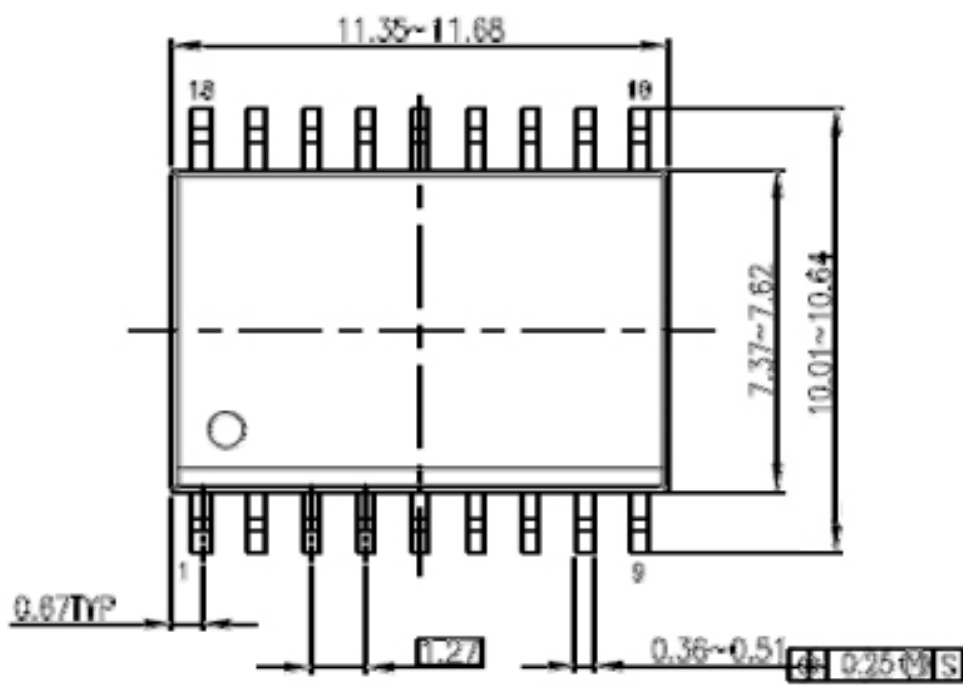
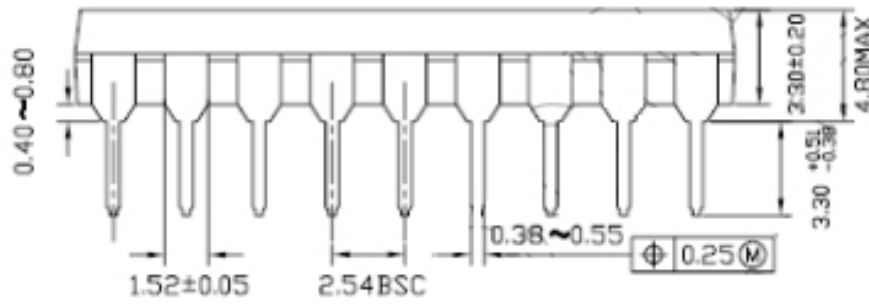
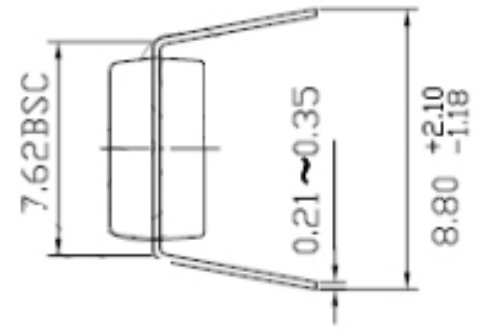

以上信息仅供参考. 如需帮助联系客服人员. 谢谢 XINLUDA