



Leading Through Innovation



**HSS-E & HSS-PM**

# COMBO TAPS

## COMBO GEWINDEBOHRER

- For Multi Purpose Tapping
- Für Mehrbereichs-Gewindebohren



HSS-E & HSS-PM COMBO TAPS

For Multi Purpose Tapping

Please visit globaly1.com/mat for material search

◎ : Excellent ○ : Good

Recommended cutting conditions : p.B110

Table with columns: ISO, VDI 3323, Material Description, Composition / Structure / Heat Treatment, HB, HRC, and a grid of suitability symbols (circles) for various materials and tap series (P, M, K, N, S, H).

Table with columns: HOLE TYPE, TOOL MATERIAL (HSS-E), CHAMFER LEAD ACC. TO DIN2197, FLUTE TYPE, SPIRAL FLUTE ANGLE, and SURFACE TREATMENT (Bright, TiN, VAP).

Table with columns: MODEL and a grid of tap images corresponding to the material suitability table.

Table with columns: HOLE TYPE, TOOL MATERIAL (HSS-E, HSS-PM), CHAMFER LEAD ACC. TO DIN2197, FLUTE TYPE, SPIRAL FLUTE ANGLE, and SURFACE TREATMENT (Bright, TiN, VAP).

Table with columns: MODEL and a grid of tap images corresponding to the material suitability table.

COMBO TAP SETS

Combo Spiral Flute Taps

TB804SET5 TC804SET7

VAP Bright

5pcs 7pcs



Combo Spiral Flute Taps + Gold-P Drill

TD804SET7-GLP195

TiN

14pcs



P.493





Vap **TB814** SERIES  
Bright **TC814** SERIES  
TiN **TD814** SERIES

**M** ISO Metric coarse threads DIN 13

- Metrisches ISO-Gewinde DIN 13
- ISO MÉTRIQUE DIN13
- ISO Metrico passo grosso DIN 13

Machine taps  
Maschinengewindebohrer

► For using multi-purpose and correct thread profiles & long tool life due to special tap geometry. YG-1 company has a patent.

► Für vielfältigen Einsatz, genaue Gewindeprofile und lange Standzeit dank einer besonderen Schneidengeometrie. Von YG-1 patentiert.

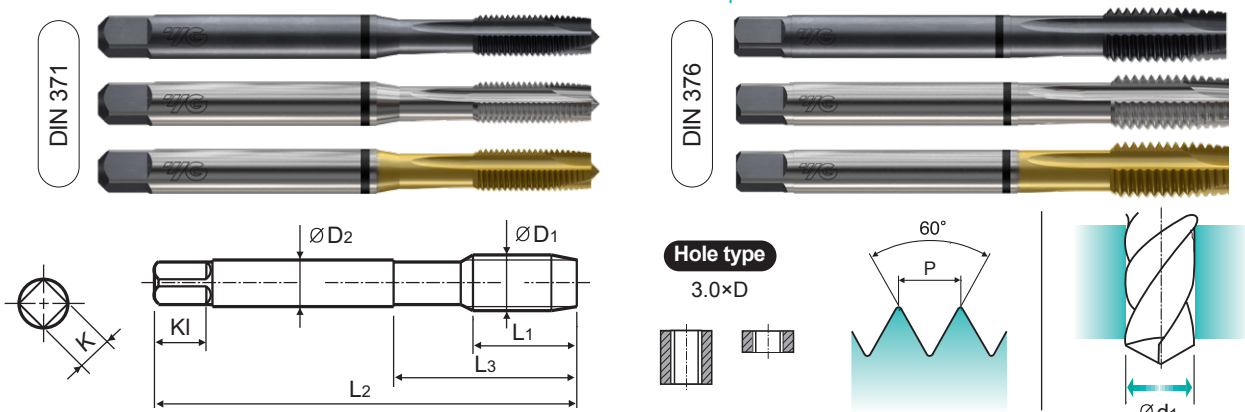

Material groups: **MU** HSS-E DIN 371/376 6H 60° B Vap Bright TiN p.B125

Recommended ToolHolder: Plain Shank TAPPING ER CHUCK TAPPING CHUCK ONE STEP TAPPING CHUCK Page D215-220 D221-228 D211-213

Unit : mm

SIZE	Pitch	EDP No.			Thread Length	Overall Length	Neck Length	Shank Diameter	Square Size	Square Length	No. of Flute	Tapping Drill Diameter
ØD1	P	Vap	Bright	TiN	L1	L2	L3	ØD2	K	KI	Z	Ød1
M24 × 3.0		TB814786	TC814786	TD814786	34	160	60	18	14.5	17	4	21
M27 × 3.0		TB814866	TC814866	TD814866	36	160	60	20	16	19	4	24
M30 × 3.5		TB814946	TC814946	TD814946	40	180	70	22	18	21	4	26.5
M33 × 3.5		-	TC814A46	TD814A46	40	180	70	25	20	23	4	29.5
M36 × 4.0		-	TC814B36	TD814B36	50	200	80	28	22	25	4	32.0
M39 × 4.0		-	TC814C06	TD814C06	50	200	80	32	24	27	4	35.0
M42 × 4.5		-	TC814C86	TD814C86	56	200	85	32	24	27	4	37.5
M45 × 4.5		-	TC814D56	TD814D56	58	220	85	36	29	32	4	40.5
M48 × 5.0		-	TC814E26	TD814E26	65	250	90	36	29	32	4	43.0
M52 × 5.0		-	TC814F36	TD814F36	65	250	90	40	32	35	4	47.0

► DIN 371(M2~M10) and DIN 376(M11~M52)  
\* The other coating(TiCN or TiAlN) is available on your request.

◎ : Excellent ○ : Good

ISO	P										M				K					
	Non-alloy steel					Low alloy steel					High alloyed steel, and tool steel				Stainless steel		Grey cast iron	Nodular cast iron		Malleable cast iron
VDI 3323	1	2	3	4	5	6	7	8	9	10	11	12	13	14	15	16	17	18	19	20
HRc	13	25	28	32	10	29	32	38	15	35	15	23	10	10	26	3	25	21	21	
HB	125	190	250	270	300	180	275	300	350	200	325	200	240	180	180	260	160	250	130	230
Recommended	○	◎	◎	◎	◎	◎	◎	◎	◎	◎	◎	◎	◎	◎	◎	◎	◎	◎	◎	◎

ISO	N					S					H										
	Aluminum-wrought alloy		Aluminum-cast, alloyed			Copper and Copper Alloys (Bronze / Brass)					Non Metallic Materials		Heat Resistant Super Alloys			Titanium Alloys		Hardened steel	Chilled Cast Iron	Hardened Cast Iron	
VDI 3323	21	22	23	24	25	26	27	28	29	30	31	32	33	34	35	36	37	38	39	40	41
HRc	21	22	23	24	25	26	27	28	29	30	31	32	33	34	35	36	37	38	39	40	41
HB	60	100	75	90	130	110	90	100			15	30	25	38	34	400Rm	1050Rm	550	630	400	550
Recommended			◎			◎	◎	◎													



Vap **TBJ05** SERIES  
Bright **TCJ05** SERIES  
TiN **TDJ05** SERIES

**M** ISO Metric coarse threads DIN 13

- Metrisches ISO-Gewinde DIN 13
- ISO MÉTRIQUE DIN13
- ISO Metrico passo grosso DIN 13

Machine taps  
Maschinengewindebohrer

► For using multi-purpose and correct thread profiles & long tool life due to special tap geometry. YG-1 company has a patent.

► Für vielfältigen Einsatz, genaue Gewindeprofile und lange Standzeit dank einer besonderen Schneidengeometrie. Von YG-1 patentiert.

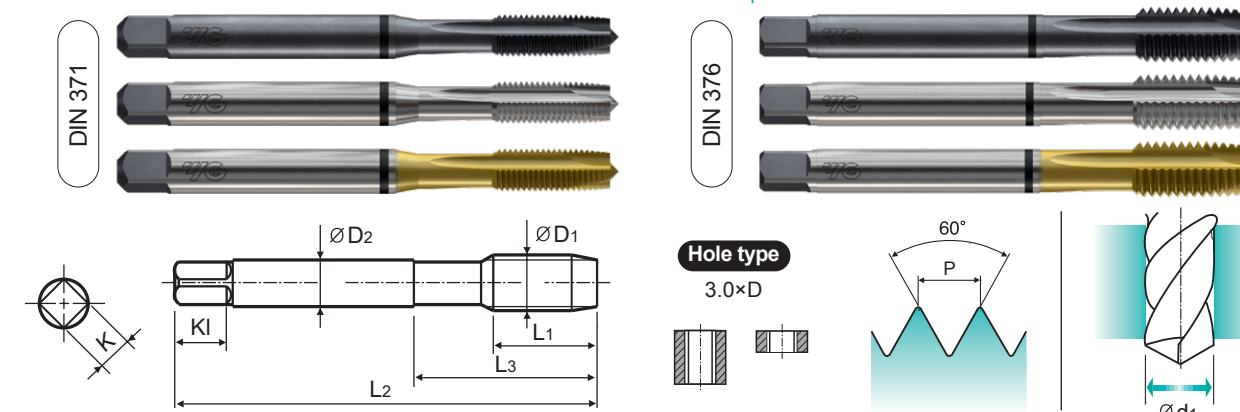

Material groups: **MU** HSS-E DIN 371/376 4H 60° B Vap Bright TiN p.B125

Recommended ToolHolder: Plain Shank TAPPING ER CHUCK TAPPING CHUCK ONE STEP TAPPING CHUCK Page D215-220 D221-228 D211-213

Unit : mm

SIZE	Pitch	EDP No.			Thread Length	Overall Length	Neck Length	Shank Diameter	Square Size	Square Length	No. of Flute	Tapping Drill Diameter
ØD1	P	Vap	Bright	TiN	L1	L2	L3	ØD2	K	KI	Z	Ød1
M2 × 0.4		TBJ05136	TCJ05136	TDJ05136	8	45	13	2.8	2.1	5	3	1.6
M2.2 × 0.45		TBJ05156	TCJ05156	TDJ05156	8	45	13	2.8	2.1	5	3	1.75
M2.3 × 0.4		TBJ05196	TCJ05196	TDJ05196	8	45	13	2.8	2.1	5	3	1.9
M2.5 × 0.45		TBJ05176	TCJ05176	TDJ05176	9	50	15	2.8	2.1	5	3	2.05
M2.6 × 0.45		TBJ05496	TCJ05496	TDJ05496	9	50	15	2.8	2.1	5	3	2.1
M3 × 0.5		TBJ05206	TCJ05206	TDJ05206	11	56	18	3.5	2.7	6	3	2.5
M3.5 × 0.6		TBJ05226	TCJ05226	TDJ05226	12	56	20	4	3	6	3	2.9
M4 × 0.7		TBJ05246	TCJ05246	TDJ05246	13	63	21	4.5	3.4	6	3	3.3
M4.5 × 0.75		TBJ05266	TCJ05266	TDJ05266	14	70	25	6	4.9	8	3	3.7
M5 × 0.8		TBJ05286	TCJ05286	TDJ05286	15	70	25	6	4.9	8	3	4.2
M6 × 1.0		TBJ05316	TCJ05316	TDJ05316	17	80	30	6	4.9	8	3	5
M7 × 1.0		TBJ05346	TCJ05346	TDJ05346	17	80	30	7	5.5	8	3	6
M8 × 1.25		TBJ05366	TCJ05366	TDJ05366	20	90	35	8	6.2	9	3	6.8
M9 × 1.25		TBJ05396	TCJ05396	TDJ05396	20	90	35	9	7	10	3	7.8
M10 × 1.5		TBJ05426	TCJ05426	TDJ05426	22	100	39	10	8	11	3	8.5
M11 × 1.5		TBJ05466	TCJ05466	TDJ05466	22	100	40	8	6.2	9	3	9.5
M12 × 1.75		TBJ05506	TCJ05506	TDJ05506	24	110	44	9	7	10	3	10.2
M14 × 2.0		TBJ05546	TCJ05546	TDJ05546	26	110	44	11	9	12	3	12
M16 × 2.0		TBJ05606	TCJ05606	TDJ05606	27	110	44	12	9	12	3	14
M18 × 2.5		TBJ05656	TCJ05656	TDJ05656	30	125	50	14	11	14	4	15.5
M20 × 2.5		TBJ05706	TCJ05706	TDJ05706	32	140	54	16	12	15	4	17.5
M22 × 2.5		TBJ05746	TCJ05746	TDJ05746	32	140	54	18	14.5	17	4	19.5
M24 × 3.0		TBJ05786	TCJ05786	TDJ05786	34	160	60	18	14.5	17	4	21
M27 × 3.0		TBJ05866	TCJ05866	TDJ05866	36	160	60	20	16	19	4	24
M30 × 3.5		TBJ05946	TCJ05946	TDJ05946	40	180	70	22	18	21	4	26.5

► DIN 371(M2~M10) and DIN 376(M11~M30)  
\* The other coating(TiCN or TiAlN) is available on your request.

◎ : Excellent ○ : Good

ISO	P										M				K					
	Non-alloy steel					Low alloy steel					High alloyed steel, and tool steel				Stainless steel		Grey cast iron	Nodular cast iron		Malleable cast iron
VDI 3323	1	2	3	4	5	6	7	8	9	10	11	12	13	14	15	16	17	18	19	20
HRc	13	25	28	32	10	29	32	38	15	35	15	23	10	10	26	3	25	21	21	
HB	125	190	250	270	300	180	275	300	350	200	325	200	240	180	180	260	160	250	130	230
Recommended	○	◎	◎	◎	◎	◎	◎	◎	◎	◎	◎	◎	◎	◎	◎	◎	◎	◎	◎	◎

ISO	N					S					H										
	Aluminum-wrought alloy		Aluminum-cast, alloyed			Copper and Copper Alloys (Bronze / Brass)					Non Metallic Materials		Heat Resistant Super Alloys			Titanium Alloys		Hardened steel	Chilled Cast Iron	Hardened Cast Iron	
VDI 3323	21	22	23	24	25	26	27	28	29	30	31	32	33	34	35	36	37	38	39	40	41
HRc	21	22	23	24	25	26	27	28	29	30	31	32	33	34	35	36	37	38	39	40	41
HB	60	100	75	90	130	110	90	100			15	30	25	38	34	400Rm	1050Rm	550	630	400	550
Recommended			◎			◎	◎	◎													



RECOMMENDED CUTTING CONDITIONS  
EMPHOHLNE SCHNEIDKONDITIONEN

Table with columns for ISO, VDI 3323, Material Description, HB, HRc, Vc (m/min), and tool types TC804, TD804, TB804, TCE05, TDE05, TBE05, TCE06, TDE06, TBE06.

Table with columns for ISO, VDI 3323, Material Description, HB, HRc, Vc (m/min), and tool types TCE07, TDE07, TBE07, TCE08, TDE08, TBE08, TC804-IC, TC633, TC807.



RECOMMENDED CUTTING CONDITIONS  
EMPHOHLNE SCHNEIDKONDITIONEN

Table with columns for ISO, VDI 3323, Material Description, HB, HRc, Vc (m/min), and tool types TB744, TC814, TD814, TB814, TCJ05, TDJ05, TBJ05, TCJ06, TDJ06, TBJ06.

Table with columns for ISO, VDI 3323, Material Description, HB, HRc, Vc (m/min), and tool types TCJ07, TDJ07, TBJ07, TCJ08, TDJ08, TBJ08, TC814-IC, TC445, TB428, TB438, TQ428, TQ438.