

PHYSICAL DIMENSIONS

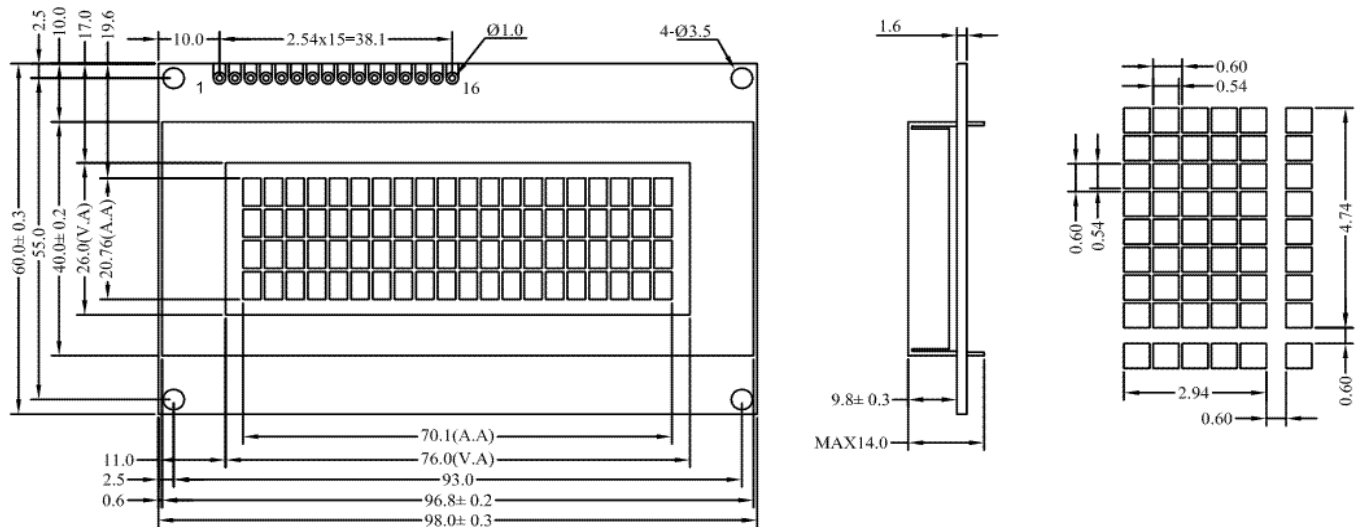

FUNCTIONS & FEATURES

Characters: 20×4 Lines low power
 LCD Mode: STN negative blue transmissive
 Controller IC: SPLC780D or Equivalent
 Viewing Angle: 6 O'clock direction
 6800 serial 8-Bit/4-Bit MPU Interface
 Backlight: LED white 2-LED 30mA
 Operating Temperature Range: -20° to +70°
 Storage Temperature Range : -30° to +80°

MECHANICAL DATA

Module size with backlight	98x60x14	[mm]
View Area	76x26	[mm]
Active Area	70,1x20,8	[mm]

PIN CONFIGURATION

1	GND	POWER GROUND
2	VDD	POWER POSITIVE 5V
3	Vo	OP.VOLTAGE FOR LCD
4	R/S	H:DATA L:INSTRUCTION
5	R/W	H:READ L:WRITE
6	E	ENABLE TRIGGER
7	DB0	DATA BUS LSB
8	DB1	DATA BUS
9	DB2	DATA BUS
10	DB3	DATA BUS
11	DB4	DATA BUS
12	DB5	DATA BUS
13	DB6	DATA BUS
14	DB7	DATA BUS MSB
15	LED +	BACKLIGHT +5V
16	LED -	BACKLIGHT 0V

BLOCK DIAGRAM

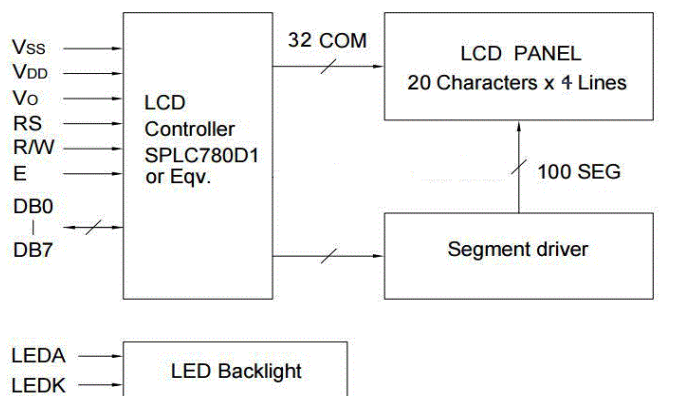

ABSOLUTE MAXIMUM RATINGS (25°)

SUPPLY VOLTAGE LOGIC	MAX. 5.5	[V]
INPUT VOLTAGE	VDD	[V]

CHARACTER TABLE

Upper 4 bit Lower 4 bit	LLLL	LLLH	LLHL	LLHH	LHLL	LHLH	LHHL	LHHH	HLLL	HLLH	HLHL	HLHH	HHLL	HHLH	HHHL	HHHH
LLLL				Ⓚ	Ⓛ	Ⓜ	Ⓝ	Ⓞ				一	ニ	三	四	五
LLLH			!	1	A	Q	9			。	ア	チ	△	▽	◇	◇
LLHL			"	2	B	R	h			「	イ	ウ	×	Ⓜ	Ⓜ	Ⓜ
LLHH			#	3	C	S	e			」	ウ	チ	毛	三	三	三
LHLL			*	4	D	T	d			、	エ	ト	ト	Ⓜ	Ⓜ	Ⓜ
LHLH			%	5	E	U	u			・	オ	オ	工	区	区	区
LHHL			Ⓚ	6	F	V	v			ヲ	カ	二	Ⓜ	Ⓜ	Ⓜ	Ⓜ
LHHH			^	7	G	W	w			ヲ	キ	変	ワ	Ⓜ	Ⓜ	Ⓜ
HLLL			Ⓚ	8	H	X	x			イ	ウ	幸	Ⓜ	Ⓜ	Ⓜ	Ⓜ
HLLH			Ⓚ	9	I	Y	y			ウ	丁	ル	ル	Ⓜ	Ⓜ	Ⓜ
HLHL			*	*	J	Z	z			王	Ⓜ	Ⓜ	Ⓜ	Ⓜ	Ⓜ	Ⓜ
HLHH			+	*	K	K	Ⓚ			オ	オ	Ⓜ	Ⓜ	Ⓜ	Ⓜ	Ⓜ
HHLL			、	Ⓚ	L	l	l			ホ	シ	ワ	ワ	Ⓜ	Ⓜ	Ⓜ
HHLH			一	=	M	m	Ⓚ			ユ	変	Ⓜ	Ⓜ	Ⓜ	Ⓜ	Ⓜ
HHHL			・	>	N	n	Ⓚ			ヨ	セ	市	Ⓜ	Ⓜ	Ⓜ	Ⓜ
HHHH			、	Ⓚ	O	o	Ⓚ			ウ	ウ	変	Ⓜ	Ⓜ	Ⓜ	Ⓜ

INSTRUCTION TABLE

Instruction	Instruction Code										Description	Execution time (fosc=270KHz)	
	RS	RW	DB7	DB6	DB5	DB4	DB3	DB2	DB1	DB0			
Clear Display	0	0	0	0	0	0	0	0	0	1	Write "20H" to DDRAM and set DDRAM address to "00H" from AC	1.52ms	
Return Home	0	0	0	0	0	0	0	0	0	1	- Set DDRAM address to "00H" from AC and return cursor to its original position if shifted. The contents of DDRAM are not changed.	1.52ms	
Entry Mode Set	0	0	0	0	0	0	0	0	1	I/D	S	Assign cursor moving direction and enable the shift of entire display	38μs
Display ON/OFF Control	0	0	0	0	0	0	0	1	D	C	B	Set display(D), cursor(C), and blinking of cursor(B) on/off control bit.	38μs
Cursor or Display Shift	0	0	0	0	0	0	1	S/C	R/L	-	-	Set cursor moving and display shift control bit, and the direction, without changing of DDRAM data.	38μs
Function Set	0	0	0	0	0	1	DL	N	F	-	-	Set interface data length (DL: 8-bit/4-bit), numbers of display line (N: 2-line/1-line) and, display font type (F:5x10 dots/5x8 dots)	38μs
Set CGRAM Address	0	0	0	1	AC5	AC4	AC3	AC2	AC1	AC0		Set CGRAM address in address counter.	38μs
Set DDRAM Address	0	0	1	AC6	AC5	AC4	AC3	AC2	AC1	AC0		Set DDRAM address in counter	38μs
Read Busy Flag and Address Counter	0	1	BF	AC6	AC5	AC4	AC3	AC2	AC1	AC0		Whether during internal operation or not can be known by reading BF. The contents of address counter can also be read.	
Write Data to RAM	1	0	D7	D6	D5	D4	D3	D2	D1	D0		Write data into internal RAM (DDRAM/CGRAM).	38μs
Read Data from RAM	1	1	D7	D6	D5	D4	D3	D2	D1	D0		Read data from internal RAM (DDRAM/CGRAM).	38μs