

## TDA Series

• 105°C 2,000Hrs assured.

- Non-solvent proof.
- For SMPS, Inverter.
- RoHS compliant.
- Halogen-free capacitors are also available.



### SPECIFICATIONS

Item	Characteristics																									
Rated Voltage Range	16 ~ 100 V <sub>DC</sub>	160 ~ 500 V <sub>DC</sub>																								
Operating Temperature Range	-40 ~ +105°C	-25 ~ +105°C																								
Capacitance Tolerance	±20% (M) (at 20°C, at 120Hz)																									
Leakage Current	I = 0.02CV(µA) or 3mA, whichever is smaller. Where, I:Max. Leakage current(µA) C:Nominal capacitance(µF) V:Rated voltage(V <sub>DC</sub> ) (at 20°C, 5 minutes)																									
* Dissipation Factor(Tanδ)	<table border="1"> <tr> <td>Rated Voltage(V<sub>DC</sub>)</td> <td>16</td> <td>25~35</td> <td>50~63</td> <td>100</td> <td>160~400</td> <td>420~500</td> </tr> <tr> <td>Tanδ(Max.)</td> <td>0.40</td> <td>0.35</td> <td>0.25</td> <td>0.20</td> <td>0.15</td> <td>0.20</td> </tr> </table> (at 20°C, 120Hz)		Rated Voltage(V <sub>DC</sub> )	16	25~35	50~63	100	160~400	420~500	Tanδ(Max.)	0.40	0.35	0.25	0.20	0.15	0.20										
Rated Voltage(V <sub>DC</sub> )	16	25~35	50~63	100	160~400	420~500																				
Tanδ(Max.)	0.40	0.35	0.25	0.20	0.15	0.20																				
Temperature Characteristics (Max.Impedance ratio)	<table border="1"> <tr> <td>Rated Voltage(V<sub>DC</sub>)</td> <td>16</td> <td>25</td> <td>35</td> <td>50~63</td> <td>100</td> <td>160~400</td> <td>420~500</td> </tr> <tr> <td>Z(-25°C)/Z(20°C)</td> <td>4</td> <td>3</td> <td>3</td> <td>2</td> <td>2</td> <td>4</td> <td>8</td> </tr> <tr> <td>Z(-40°C)/Z(20°C)</td> <td>15</td> <td>10</td> <td>8</td> <td>6</td> <td>5</td> <td>-</td> <td>-</td> </tr> </table> (at 120Hz)		Rated Voltage(V <sub>DC</sub> )	16	25	35	50~63	100	160~400	420~500	Z(-25°C)/Z(20°C)	4	3	3	2	2	4	8	Z(-40°C)/Z(20°C)	15	10	8	6	5	-	-
Rated Voltage(V <sub>DC</sub> )	16	25	35	50~63	100	160~400	420~500																			
Z(-25°C)/Z(20°C)	4	3	3	2	2	4	8																			
Z(-40°C)/Z(20°C)	15	10	8	6	5	-	-																			
Load Life	The following specifications shall be satisfied when the capacitors are restored to 20°C after the rated voltage is applied for 2,000 hours at 105°C. Capacitance change ≤ ±20% of the initial value Tanδ ≤ 200% of the initial specified value Leakage Current ≤ The initial specified value																									
Shelf Life	The following specifications shall be satisfied when the capacitors are restored to 20°C after the exposing them at 105°C for 1,000 hours without voltage applied. The rated voltage shall be applied to the capacitors for a minimum of 30 minutes, at least 24 hours and not more than 48 hours before the measurements. Capacitance change ≤ ±20% of the initial value Tanδ ≤ 200% of the initial specified value Leakage Current ≤ The initial specified value																									
Others	Satisfied characteristics KS C IEC 60384-4																									

\* For capacitors with CV products > 100,000 Higher Tanδ value may apply.  
When the capacitors exceed 1,000µF, 0.01 shall be added every 1,000µF increase.

### RATED RIPPLE CURRENT

When capacitors are operated in any other condition at 120Hz, the maximum ripple current must be multiplied by the figure shown in the table.

Frequency multiplying factor

V <sub>DC</sub> \ Freq.(Hz)	60	120	300	1k	10k~
16~50V <sub>DC</sub>	0.95	1.00	1.03	1.05	1.08
63~100V <sub>DC</sub>	0.92	1.00	1.07	1.13	1.19
160~250V <sub>DC</sub>	0.81	1.00	1.17	1.32	1.45
315~500V <sub>DC</sub>	0.77	1.00	1.16	1.30	1.41

### DIMENSIONS OF TDA Series

Unit(mm)

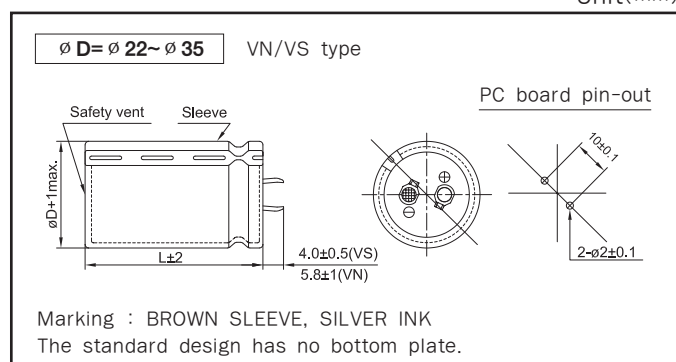

RATINGS OF TDA Series

μF \ V <sub>DC</sub> / ∅ D	16				25				35			
	22	25.4	30	35	22	25.4	30	35	22	25.4	30	35
3,300									22 × 25 1.40			
3,900									22 × 30 1.57			
4,700					22 × 25 1.50				22 × 30 1.72	25.4 × 25 1.80		
5,600					22 × 25 1.63				22 × 35 1.95	25.4 × 30 1.96	30 × 25 1.99	
6,800	22 × 25 1.57				22 × 30 1.86	25.4 × 25 1.87			22 × 40 2.20	25.4 × 35 2.23	30 × 25 2.19	
8,200	22 × 30 1.73				22 × 35 2.11	25.4 × 30 2.12	30 × 25 2.15		22 × 50 2.55	25.4 × 40 2.53	30 × 30 2.53	
10,000	22 × 30 1.97	25.4 × 25 1.97			22 × 40 2.39	25.4 × 35 2.42	30 × 25 2.39			25.4 × 45 2.87	30 × 35 2.90	35 × 30 2.75
12,000	22 × 35 2.22	25.4 × 30 2.24			22 × 45 2.69	25.4 × 40 2.74	30 × 30 2.70	35 × 25 2.74		25.4 × 50 3.24	30 × 40 3.23	35 × 30 3.23
15,000	22 × 40 2.55	25.4 × 35 2.58				25.4 × 45 3.15	30 × 35 3.13	35 × 30 3.27			30 × 45 3.72	35 × 35 3.67
18,000	22 × 45 2.87	25.4 × 40 2.92	30 × 30 2.88			25.4 × 50 3.54	30 × 40 3.54	35 × 30 3.50				35 × 40 4.37
22,000		25.4 × 45 3.32	30 × 35 3.29				30 × 45 4.04	35 × 35 3.97				35 × 50 4.92
27,000		25.4 × 50 3.78	30 × 40 3.77	35 × 30 3.45				35 × 45 4.73				
33,000			30 × 45 4.30	35 × 35 4.26				35 × 50 5.39				
39,000			30 × 50 4.81	35 × 40 4.79								
47,000				35 × 50 5.43								

μF \ V <sub>DC</sub> / ∅ D	50				63				100			
	22	25.4	30	35	22	25.4	30	35	22	25.4	30	35
560									22 × 25 1.06			
820									22 × 30 1.32	25.4 × 25 1.33		
1,000									22 × 35 1.50	25.4 × 30 1.51		
1,200					22 × 25 1.19				22 × 40 1.69	25.4 × 35 1.71	30 × 25 1.68	
1,500					22 × 25 1.33				22 × 45 1.94	25.4 × 40 1.98	30 × 30 1.95	
1,800	22 × 25 1.33				22 × 30 1.51	25.4 × 25 1.52				25.4 × 45 2.23	30 × 35 2.26	35 × 25 2.17
2,200	22 × 30 1.50				22 × 35 1.73	25.4 × 30 1.74				25.4 × 50 2.53	30 × 40 2.57	35 × 30 2.50
2,700	22 × 30 1.69	25.4 × 25 1.70			22 × 40 1.97	25.4 × 35 1.99	30 × 25 1.91				30 × 45 2.88	35 × 35 2.86
3,300	22 × 35 1.93	25.4 × 30 1.85			22 × 50 2.29	25.4 × 40 2.27	30 × 30 2.24				30 × 50 3.28	35 × 40 3.27
3,900	22 × 40 2.16	25.4 × 35 2.18	30 × 25 2.15			25.4 × 45 2.54	30 × 35 2.56	35 × 25 2.56				35 × 45 3.67
4,700	22 × 45 2.43	25.4 × 35 2.39	30 × 30 2.35	35 × 25 2.48		25.4 × 50 2.86	30 × 40 2.86	35 × 30 2.79				35 × 50 3.80
5,600	22 × 50 2.75	25.4 × 40 2.70	30 × 35 2.76	35 × 25 2.70			30 × 45 3.22	35 × 35 3.19				
6,800		25.4 × 50 3.30	30 × 40 3.30	35 × 30 3.25			30 × 50 3.66	35 × 40 3.64				
8,200			30 × 45 3.60	35 × 35 3.56				35 × 45 3.90				
10,000			30 × 50 4.04	35 × 40 4.03				35 × 50 4.40				
12,000				35 × 45 4.56	← Case Size ∅ D × L (mm) ← Rated Ripple Current (Arms/105°C, 120Hz)							



# LARGE SIZED ALUMINUM ELECTROLYTIC CAPACITORS

## RATINGS OF TDA Series

V <sub>DC</sub> μF / ∅ D	160				200				250			
	22	25.4	30	35	22	25.4	30	35	22	25.4	30	35
100												
120										25.4 × 20 0.48		
150					22 × 20 0.53					25.4 × 20 0.59		
180					22 × 20 0.62	25.4 × 20 0.64			22 × 25 0.78	25.4 × 20 0.75		
220		25.4 × 20 0.66			22 × 25 0.70	25.4 × 20 0.70			22 × 30 0.96	25.4 × 25 0.95	30 × 20 0.93	
270		25.4 × 20 0.80			22 × 25 0.87	25.4 × 20 0.83			22 × 30 1.11	25.4 × 25 1.10	30 × 20 1.10	
330	22 × 25 1.20	25.4 × 20 1.10			22 × 30 1.20	25.4 × 25 1.21	30 × 20 1.20		22 × 35 1.20	25.4 × 30 1.20	30 × 25 1.26	35 × 20 1.17
390	22 × 30 1.30	25.4 × 25 1.29	30 × 20 1.19		22 × 30 1.28	25.4 × 25 1.27	30 × 25 1.25		22 × 40 1.45	25.4 × 35 1.49	30 × 25 1.44	35 × 25 1.49
470	22 × 30 1.36	25.4 × 25 1.39	30 × 20 1.31	35 × 20 1.35	22 × 35 1.41	25.4 × 30 1.41	30 × 25 1.50	35 × 20 1.30	22 × 45 1.53	25.4 × 35 1.50	30 × 30 1.57	35 × 25 1.57
560	22 × 35 1.46	25.4 × 30 1.51	30 × 25 1.54	35 × 20 1.41	22 × 45 1.56	25.4 × 35 1.53	30 × 30 1.57	35 × 25 1.52	22 × 50 1.77	25.4 × 40 1.74	30 × 30 1.73	35 × 25 1.72
680	22 × 40 1.66	25.4 × 30 1.65	30 × 25 1.68	35 × 20 1.69	22 × 45 1.73	25.4 × 35 1.69	30 × 30 1.74	35 × 25 1.72		25.4 × 50 1.84	30 × 35 1.94	35 × 30 1.97
820	22 × 45 1.99	25.4 × 30 1.95	30 × 30 2.00	35 × 25 1.91		25.4 × 45 1.99	30 × 35 2.00	35 × 30 2.04		25.4 × 60 2.20	30 × 40 2.10	35 × 35 1.98
1,000	22 × 50 2.18	25.4 × 40 2.14	30 × 30 2.15	35 × 25 2.17		25.4 × 50 2.21	30 × 40 2.23	35 × 35 2.30			30 × 50 2.31	35 × 40 2.30
1,200		25.4 × 45 2.39	30 × 35 2.37	35 × 30 2.41		25.4 × 60 2.57	30 × 45 2.53	35 × 35 2.57			30 × 60 2.50	35 × 45 2.43
1,500		25.4 × 60 2.87	30 × 40 2.74	35 × 35 2.79			30 × 50 3.01	35 × 40 2.99				35 × 50 2.80
1,800			30 × 45 3.14	35 × 35 3.11			30 × 60 3.47	35 × 45 3.38				
2,200			30 × 60 3.76	35 × 45 3.66				35 × 60 3.60				

V <sub>DC</sub> μF / ∅ D	315				350				400			
	22	25.4	30	35	22	25.4	30	35	22	25.4	30	35
47									22 × 20 0.22			
68									22 × 25 0.51	25.4 × 20 0.46		
82	22 × 25 0.64				22 × 25 0.56				22 × 25 0.55	25.4 × 20 0.53		
100	22 × 30 0.68				22 × 25 0.67				22 × 30 0.67	25.4 × 25 0.67	30 × 20 0.60	
120	22 × 30 0.75	25.4 × 25 0.76			22 × 30 0.73	25.4 × 25 0.73			22 × 35 0.76	25.4 × 30 0.76	30 × 25 0.76	35 × 20 0.70
150	22 × 35 0.82	25.4 × 30 0.83			22 × 35 0.83	25.4 × 30 0.83	30 × 25 0.83		22 × 40 0.82	25.4 × 30 0.80	30 × 25 0.82	35 × 20 0.80
180	22 × 40 0.91	25.4 × 30 0.88	30 × 25 0.85		22 × 40 0.89	25.4 × 30 0.89	30 × 25 0.91		22 × 45 0.88	25.4 × 35 0.88	30 × 30 0.89	35 × 25 0.90
220	22 × 45 0.94	25.4 × 35 0.96	30 × 30 1.00		22 × 45 0.98	25.4 × 35 0.98	30 × 30 0.98	35 × 25 0.96	22 × 50 1.01	25.4 × 40 0.99	30 × 30 0.98	35 × 25 1.02
270		25.4 × 45 1.13	30 × 35 1.12	35 × 25 1.06	22 × 50 1.12	25.4 × 40 1.10	30 × 30 1.08	35 × 25 1.12		25.4 × 45 1.12	30 × 35 1.12	35 × 30 1.16
330		25.4 × 50 1.28	30 × 40 1.28	35 × 30 1.30		25.4 × 45 1.24	30 × 40 1.24	35 × 30 1.29		25.4 × 50 1.27	30 × 40 1.28	35 × 35 1.35
390			30 × 45 1.44	35 × 35 1.42		25.4 × 60 1.47	30 × 40 1.40	35 × 35 1.47		25.4 × 60 1.51	30 × 45 1.49	35 × 35 1.47
470			30 × 50 1.63	35 × 40 1.64		25.4 × 60 1.70	30 × 45 1.67	35 × 35 1.65			30 × 50 1.63	35 × 40 1.62
560				35 × 45 1.87			30 × 50 1.87	35 × 40 1.86			30 × 60 1.88	35 × 50 1.88
680				35 × 50 2.07			30 × 60 2.18	35 × 50 2.18				35 × 60 2.19
820								35 × 60 2.53				

← Case Size ∅ D × L (mm)  
 ← Rated Ripple Current (Arms/105°C, 120Hz)

**RATINGS OF TDA Series**

$\mu F$	$V_{DC}$ $\phi D$	420				450				500			
		22	25.4	30	35	22	25.4	30	35	22	25.4	30	35
56						22 × 25 0.40				22 × 35 0.46	25.4 × 30 0.46	30 × 30 0.48	
68	22 × 25 0.50					22 × 30 0.50	25.4 × 25 0.50			22 × 40 0.53	25.4 × 35 0.53	30 × 30 0.55	
82	22 × 25 0.51	25.4 × 25 0.63				22 × 30 0.55	25.4 × 25 0.54			22 × 45 0.56	25.4 × 35 0.58	30 × 35 0.58	
100	22 × 30 0.58	25.4 × 30 0.69				22 × 35 0.62	25.4 × 30 0.62	30 × 25 0.64			25.4 × 40 0.65	30 × 35 0.66	
120	22 × 35 0.72	25.4 × 30 0.73	30 × 25 0.75			22 × 40 0.70	25.4 × 35 0.71	30 × 30 0.72	35 × 25 0.73		25.4 × 45 0.75	30 × 40 0.76	35 × 30 0.78
150	22 × 45 0.79	25.4 × 35 0.74	30 × 25 0.75	35 × 25 0.81		22 × 45 0.77	25.4 × 40 0.75	30 × 30 0.74	35 × 25 0.75			30 × 45 0.80	35 × 35 0.81
180	22 × 50 0.89	25.4 × 40 0.89	30 × 30 0.88	35 × 25 0.87			25.4 × 45 0.84	30 × 35 0.87	35 × 30 0.88			30 × 50 0.90	35 × 40 0.93
220		25.4 × 45 1.01	30 × 35 1.00	35 × 30 1.05			25.4 × 50 0.98	30 × 40 0.98	35 × 30 1.00			30 × 60 1.10	35 × 45 1.11
270			30 × 45 1.19	35 × 35 1.19			25.4 × 60 1.17	30 × 45 1.15	35 × 35 1.17				35 × 50 1.28
330			30 × 50 1.36	35 × 40 1.39				30 × 50 1.38	35 × 40 1.38				35 × 60 1.50
390				35 × 45 1.57				30 × 60 1.60	35 × 45 1.56				
470				35 × 50 1.73					35 × 50 1.72				
560									35 × 60 1.98	← Case Size $\phi D \times L$ (mm) ← Rated Ripple Current(Arms/105°C, 120Hz)			