

REV.	DESCRIPTION	DRAWN	CHECKED	APPROVED
A	NEW RELEASE	YCH 02/01/07	~	LJC 02/01/07
B	整理圖	YCH 08/15/07	~	LJC 08/15/07
D	Drawing Update	JLZ 07/25/16'	~	

- NOTES:
- ELECTRICAL CHARACTERISTICS:
 - CONTACT RESISTANCE: 30m Ω ? Max.INITIAL.
 - DIELECTRIC WITHSTANDING VOLTAGE:500V AC(rms) FOR 1 MINUTE.
 - INSULATION RESISTANCE:1000M Ω ? Min.
 - MECHANICAL CHARACTERISTICS:
 - DURABILITY: 300 CYCLES.
 - ENVIRONMENT CHARACTERISTICS:
 - TEMPERATURE RANGE: -40°C~+105°C.
 - PRODUCT NUMBER CODE:
DS1036 - XX X X X X X X - YT
- SCREW TYPE
 - X:W/O SCREW
 - 1:CC TYPE
 - 2:CS TYPE
 - RIVET TYPE
 - P:W/ THREAD(UNC #4-40)
 - N:W/O THREAD(FOR W/O SCREW ONLY)
 - CONTACT PLATING
 - 2: GOLD+NICKEL
 - HOUSING COLOR
 - U:BLUE
 - B:BLACK
 - STRAIN RELIEF
 - P:W/
 - N:W/O
 - CONNECTOR TYPE
 - M:MALE
 - F:FEMALE
 - No.OF CONTACTS
 - 09:9pos 15:15pos
 - 25:25pos 37:37pos

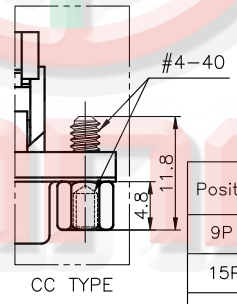

Position	A±0.1	B±0.2	C±0.2	D±0.2		E±0.2
				Male	Female	
9P	10.16	30.80	24.99	17.90	16.33	19.00
15P	17.78	39.14	33.32	26.50	24.66	27.34
25P	30.48	53.04	47.04	40.00	38.38	41.24
37P	45.72	69.32	63.50	56.50	54.84	57.52

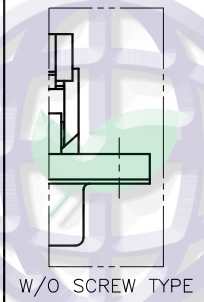
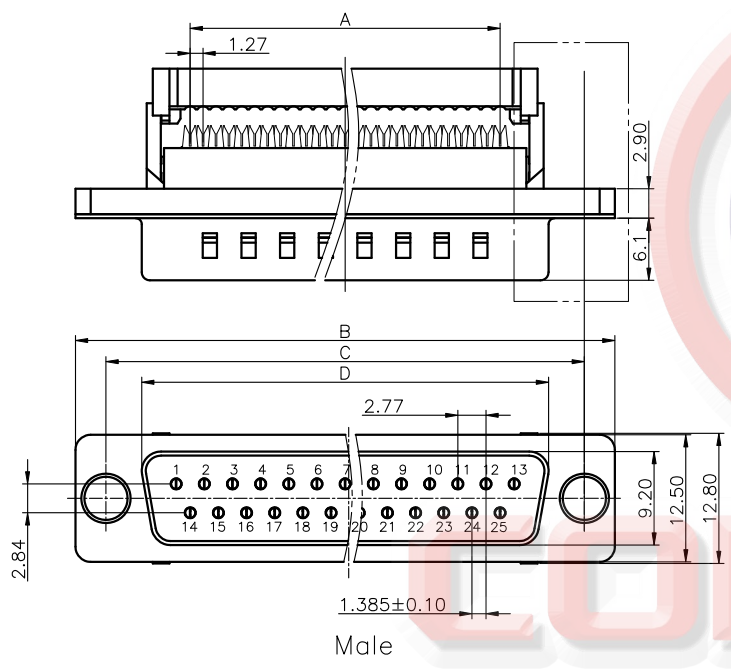
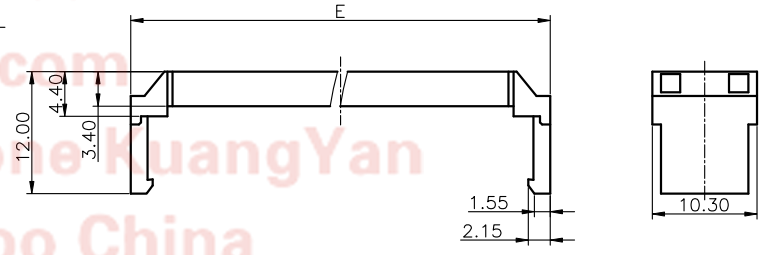
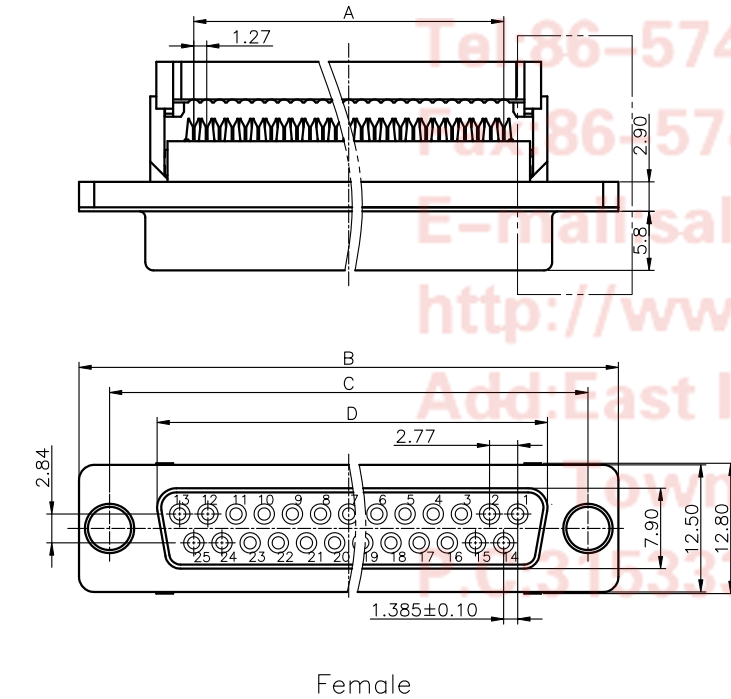
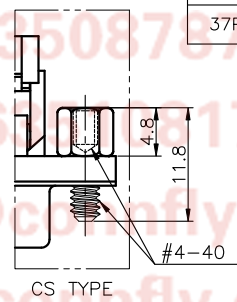

GENERAL TOLERANCE	ANGLE TOLERANCE
X. ±0.60	X. ±3°
.X ±0.38	.X ±2°
.XX ±0.25	.XX ±1°

PROJECTION	TITLE	I.D.C D-SUB	
UNITS	mm		
SHEET SIZE	A4	SERIES	DS1036 SERIES

DRAWING TYPE	CUSTOMER
SCALE	1:1 SHEET 1 OF 1
DRAWING NO.	C-DS1036-XXXXXXXX-YT-D

 晨翔电子有限公司
CONNFLY CONNFLY ELECTRONIC CO. LTD