



# CHIP TRIMMER CAPACITOR



Chip Ceramic Trimmer Capacitor **TZC03** Series

## Chip Trimmer Capacitor with Minus & Cross Slot.

### ■FEATURES

1. Small size:3.2(W)×4.5(L)×1.6(H)mm.  
(Cross slot type:1.7(H)mm)
2. Color coded stator permits easy identification of capacitance and reduces mounting errors.
3. Can be adjusted with conventional adjustment tools (Standard type) having a thickness of 0.5mm.
4. Available for cross slot type to provide better adjustability.
5. Providing mechanism to prevent air leak offers better mountability with automatic mounter.(Cross slot type)
6. Designed for automatic placement in surface mount applications.
7. Heat resistant resin withstands reflow soldering temperatures.

### ■APPLICATIONS

- Compact radios, Headphones stereos
- Pagers
- Camcorders
- Mobile telephones
- Hybrid ICs
- Cordless telephones
- Portable radio equipment

### ■PART NUMBERING

(Please specify the part number when ordering.)

(Ex.) 

TZC03	Z	060	A	110	T00
①	②	③	④	⑤	⑥

① Model Number

② Temperature Coefficient Characteristics

③ Capacitance Value

④ Terminal Style

⑤ Other Specifications 110:Standard Type (Minus Slot)

310:Cross Slot Type

⑥ Packaging Code T00:Taping 1,000pcs./reel (180mm dia.)

T01:Taping 4,000pcs./reel (330mm dia.)

No Code:Bulk Package 500pcs./bag

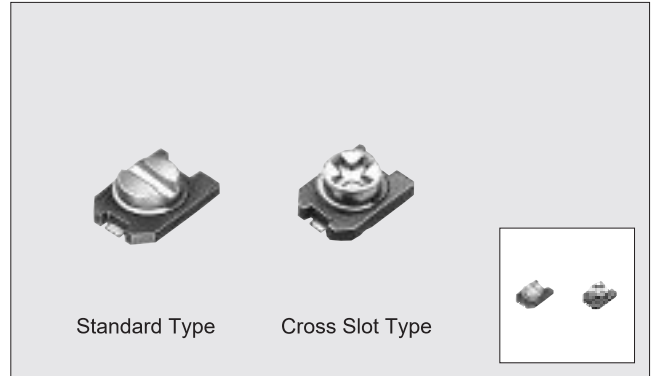

### ■CONSTRUCTION

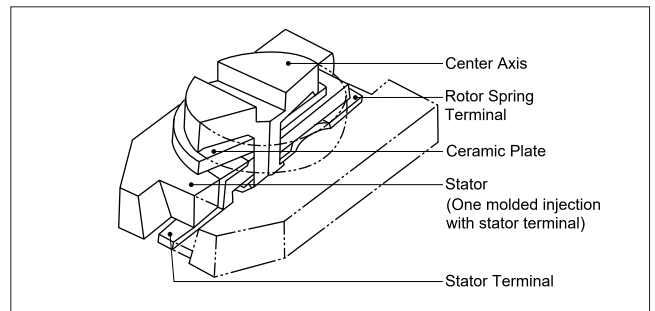

**■ DIMENSIONS/STANDARD LAND PATTERNS**

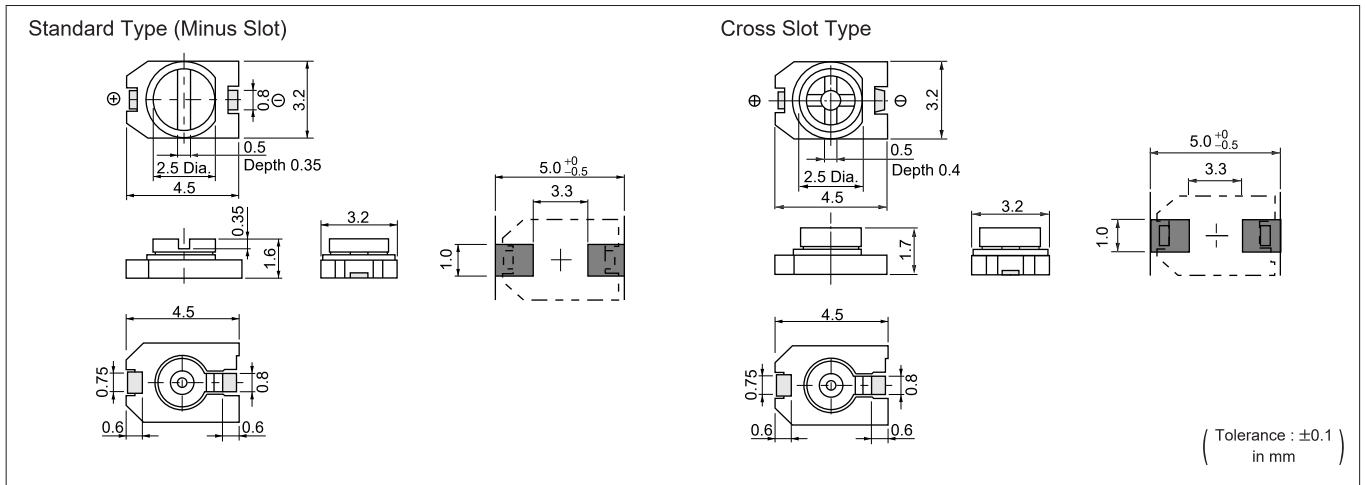

**■ RATINGS**

Part Number	Capacitance (pF)		Temperature Coefficient (ppm/°C)	Q <1MHz, Cmax.>	Stator Color
	Min. (max.)	Max. (±50%)			
TZC03Z030A□□□	1.4	3.0	NP0 ±300 (0±300)	300 min.	Brown
TZC03Z060A□□□	2.0	6.0	NP0 ±300 (0±300)	500 min.	Blue
TZC03R100A□□□	3.0	10.0	N750 ±300 (-750±500)	500 min.	White
TZC03P200A□□□	5.0	20.0	N1200±500 (-1200±500)	300 min.	Red
TZC03P300A□□□	6.5	30.0	N1200±500 (-1200±500)	300 min.	Green

•Rated Voltage:100Vdc •Withstanding Voltage:220Vdc •Insulation Resistance:10<sup>4</sup>MΩmin.  
 •Driving Torque:1.5 to 10.0 mN·m (Ref.15 to 100g·cm) •Working Temperature Range:-25 to +85°C

**■ CHARACTERISTICS**

● Temperature Coefficient Characteristics

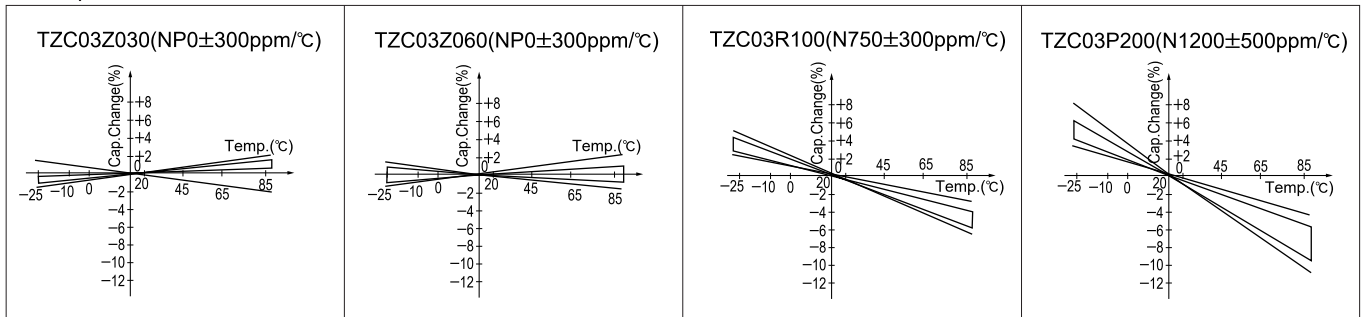

● Q and Capacitance vs. Frequency Characteristics

Characteristics are measured at the maximum rated capacitance value position.

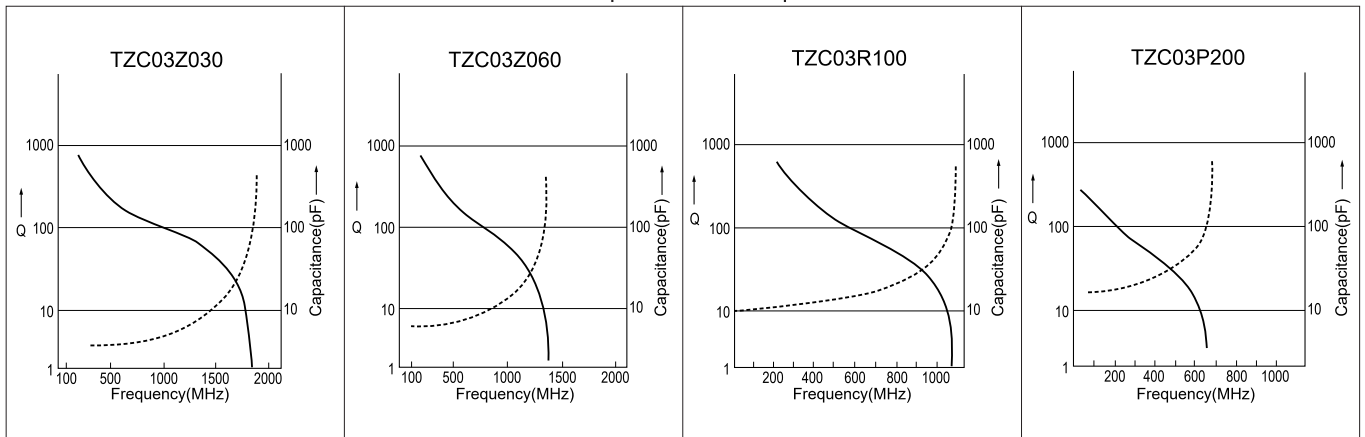

Q : Solid line Capacitance : Dotted line

**■ TAPING SPECIFICATIONS / HANDLING PRECAUTIONS / SOLDERING CONDITIONS**

● See pages 19 to 21.



# CHIP TRIMMER CAPACITOR



Chip Ceramic Trimmer Capacitor **TZBX4** Series

## Color-coded Case Facilitates Identification Wide Variation with 4mm Package

### FEATURES

1. Color-coded case facilitates identification of capacitance range.
2. Miniature rectangular shape : 4.0(W)×4.5(L)×3.0(H)mm.
3. Specifically designed for automatic surface placement.
4. Designed to withstand flux baths and solder baths. (cover film type)
5. Can be temporarily attached to PCB with adhesives. (terminal styles A and B)
6. Can be reflow and flow soldered.
7. Stable characteristics over a wide frequency range. (resonant frequency : 1000 MHz min./6pF)

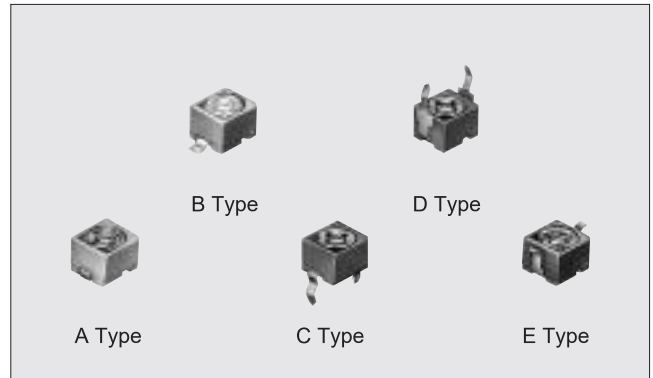

### APPLICATIONS

- Camcorders
- Cordless telephones
- Mobile telephones, Car telephones
- Pagers
- Personal computers
- Car audio systems
- Hybrid circuits
- Other compact electronic equipment

### PART NUMBERING

(Please specify the part number when ordering.)

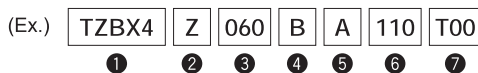

- ① Model Number
- ② Temperature Coefficient Characteristics
- ③ Capacitance Value
- ④ Cover Film  
(A: not provided, B: provided)
- ⑤ Terminal Style  
(A, B, C, D and E Type)
- ⑥ Other Specifications 110: Standard
- ⑦ Packaging Code  
(Tape and reel package is available for terminal styles A, B and E.)  
T00: Taping 500pcs./reel(180mm dia.)  
T02: Taping 2,500pcs./reel(330mm dia.)  
No Code: Bulk Package 500pcs./bag

### CONSTRUCTION

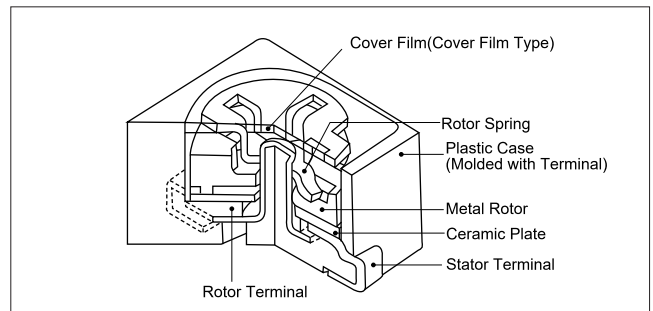

### MARKING (Black case only)

