

1. Description, Features and Applications

Descriptions:

B10Cs Series fast-acting square Surface Mount fuses are ceramic tube/end cap constructions, RoHS compliant, Halogen Free and lead(Pb) exempts of the requirements of RoHS RoHS Directive (EU) 2015/863 amending Annex II to Directive 2011/65/EU, with U.S. (UL/CSA) safety agency approvals. Provide board level primary and secondary circuit protection in a wide variety of applications. With excellent inrush current withstanding capability, excellent reliability for thermal and mechanic shock, also have a high reliability and stable solder ability, end caps are available in gold/silver/nickel plated.

Features:

- Fast-Acting
- Wide range of current rating available
- Low temperature de-rating
- Tape and Reel for automatic placement
- Small size(6.1mm*2.5mm)
- Wide operating temperature range
- RoHS compliant
- Conflict free metals

Applications:



- LED lighting
- LCD backlight inverter
- PC server
- Wireless base station
- Digital camera
- Notebook PC
- Portable Devices
- Cooling fan system
- White goods
- Industrial equipment
- Battery devices
- Power supply
- Storage system
- Game console
- Medical equipment
- LCD/PDP devices
- Networking devices
- Telecom system
- Office equipment
- Automotive devices

2. Standards and Agency Approvals



2.1 UL 248-14。

Standards: In accordance with UL 248-14.

2.2 Certification:

Agency	Ampere Range	Agency File Number
	50mA ~ 7A	E340427(JDYX2)
	50mA ~ 7A	E340427(JDYX8)

2.3 Catalogue No., ● Approved / ○ Pending

Catalog No.	Ampere Rating	Voltage Rating	Breaking Capacity	Nominal Cold Resistance (Ohms)	I ² TMelting Integral(A ² .S)	Agency Approvals	
							
B10Cs250-250	250mA	250Vac	50A@250VAC 200A@125VAC	0.860	0.145	●	●
B10Cs300-250	300mA			0.620	0.162	●	●
B10Cs315-250	315mA			0.550	0.189	●	●
B10Cs375-250	375mA			0.470	0.200	●	●
B10Cs400-250	400mA			0.380	0.238	●	●
B10Cs500-250	500mA			0.320	0.275	●	●
B10Cs600-250	600mA			0.285	0.470	●	●
B10Cs630-250	630mA			0.256	0.566	●	●
B10Cs700-250	700mA			0.208	0.805	●	●
B10Cs750-250	750mA			0.175	1.240	●	●
B10Cs800-250	800mA			0.155	1.880	●	●
B10CsA01.00-250	1A			0.148	3.500	●	●
B10CsA01.25-250	1.25A			0.102	4.760	●	●
B10CsA01.50-250	1.5A			0.085	6.305	●	●
B10CsA01.60-250	1.6A			0.072	7.610	●	●
B10CsA02.00-250	2A			0.044	8.950	●	●
B10CsA02.50-250	2.5A			0.043	16.025	●	●
B10CsA03.00-250	3A			0.033	21.560	●	●
B10CsA03.15-250	3.15A			0.029	22.750	●	●
B10CsA03.50-250	3.5A			0.027	27.050	●	●
B10CsA04.00-250	4A			0.025	31.808	●	●
B10CsA05.00-250	5A	0.019	40.250	●	●		
B10CsA06.00-250	6A	0.018	67.245	●	●		
B10CsA06.30-250	6.3A	0.017	107.550	●	●		
B10CsA07.00-250	7A	0.015	132.780	●	●		

DC Cold Resistance are measured at <10% of rated current in ambient temperature of 25°C;

Typical Prearcing I²t are calculated at 10* In Current or 8ms;

4. Dimensions and Structure

Unit: mm

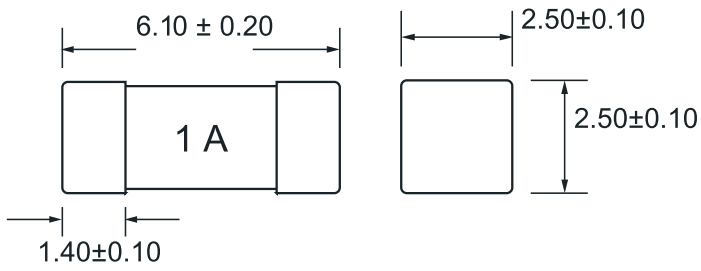

Recommended pad layout

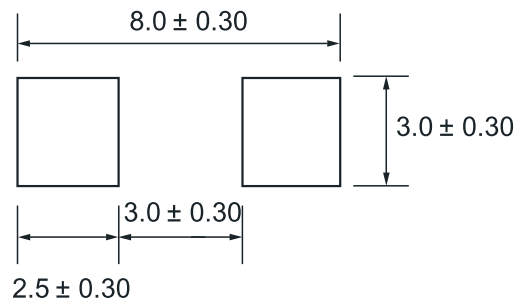

4. Material Details

NO.	Part Name	Material
①	End caps	Au Plated Brass Cap
②	Body	Non-Transparent Square Ceramic Tube
③	Fuse element	Cu-Ag Alloy wire

5. Product Characteristics

NO.	Item	Content	Reference standards
1	Product Marking	Brand, Ampere Rating	marking standards
2	Operating Temperature	-55°C to 125°C	IEC60068 -2-1/2
3	Solderability	T=240°C ± 5°C , t=3sec±0.5sec, Coverage ≥ 95%	MIL -STD -202, Method 208
4	Resistance to Soldering Heat	10 sec at 260°C	MIL -STD -202, Method 210, Test condition B
5	Insulation Resistance (after Opening)	10,000 ohms minimum	MIL -STD -202, Method 302, Test Condition A
6	Thermal Shock	5 cycles, -65°C / +125°C, 15 minutes at each extreme	MIL -STD -202, Method 107, Test Condition B
7	Mechanical Shock	100G's peak for 6 milliseconds, 3 cycles	MIL -STD -202, Method 213, Test I
8	Vibration	0.03" amplitude, 10-55 Hz in 1 min. 2hrs each XYZ=6hrs	MIL -STD -202, Method 201
9	Moisture Resistance	10 cycles	MIL -STD -202, Method 106
10	Salt Spray	5% salt solution, 48hrs	MIL -STD -202, Method 101, Test Condition B

6. Electrical Characteristics

6.1 Test Condition

All electrical test is to be conducted with the ambient air at a temperature of 25°C.

6.2 Interrupting Rating:

Breaking Capacity: 50A@250Vac , 200A@125Vac.

6.3 Operating Characteristics

% of Ampere Rating (In)	Blowing Time
100% * In	(4 hours Min)
200% * In	(120 sec Max)

6.4 Average Time Current Curves

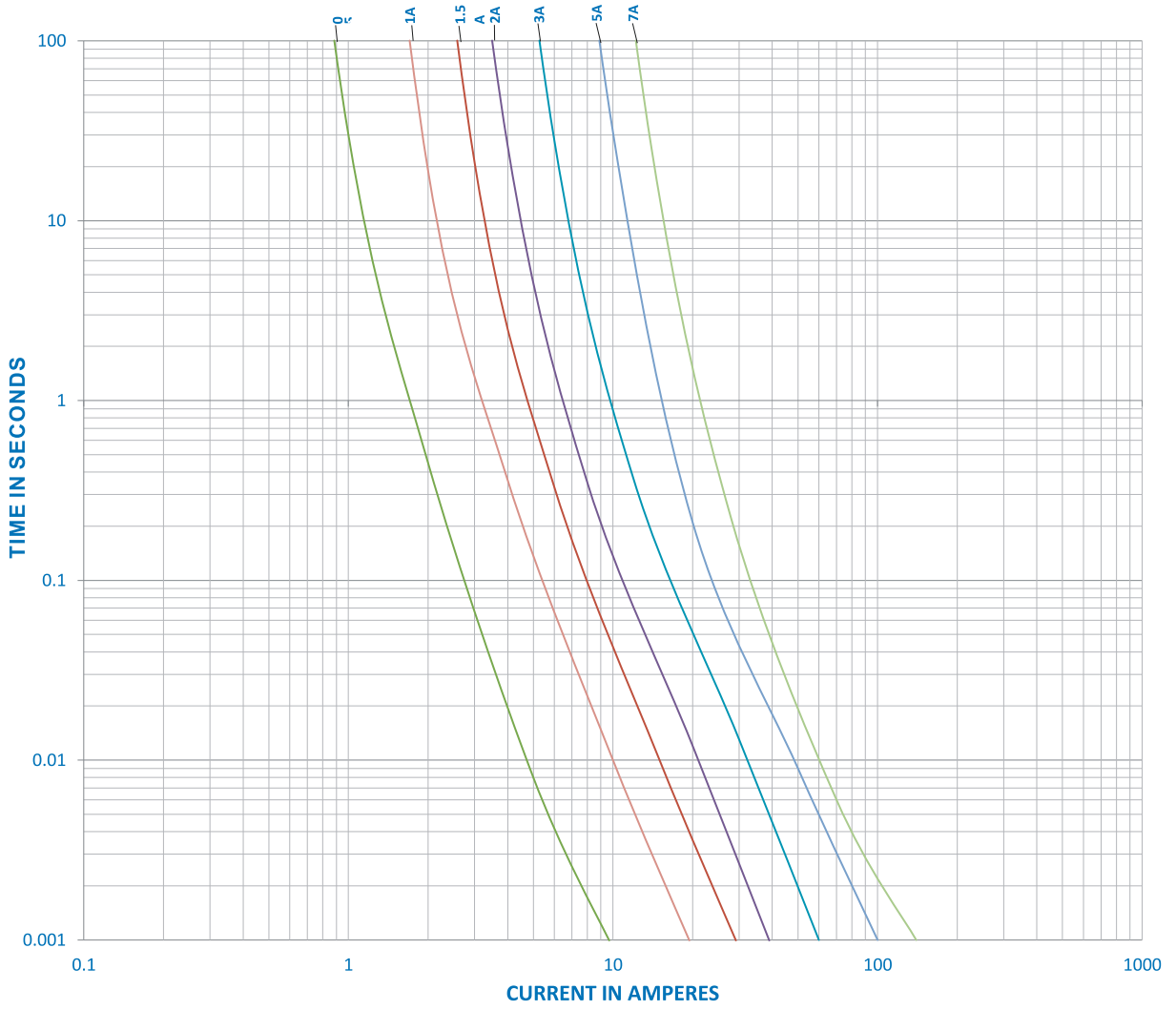

7. Environmental Characteristic

When choosing the fuse's specification, if the operating environmental temperature beyond the scope from 20~30°C, engineer should consider the environmental temperature's affection to fuses.

Please refer: Temperature Rerating Curve:

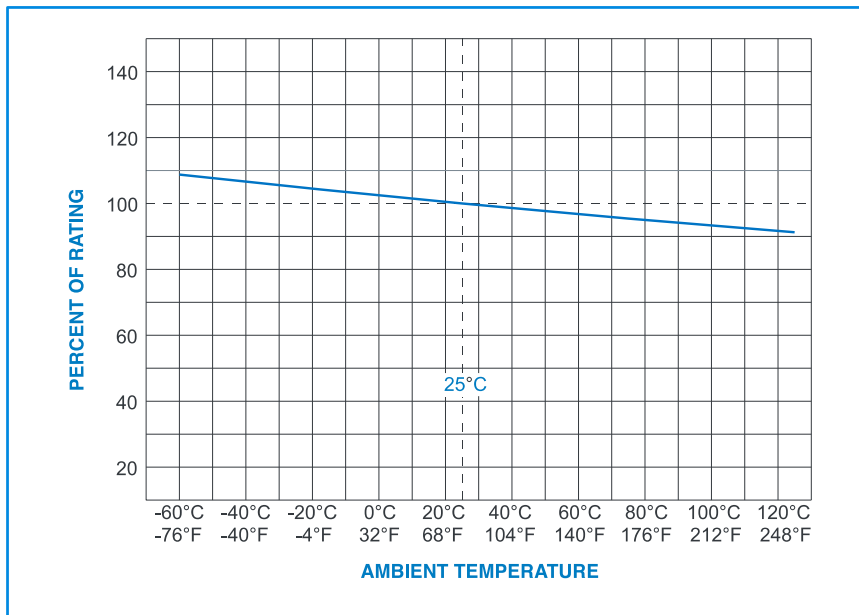

8. Recommended Soldering Parameters

A. Wave Soldering Parameters:

Solder Pot Temperature: 260°C

Max; Solder Dwell Time: 5 seconds max

Reflow Condition		Pb-Free assembly
Average ramp-up rate (Ts(max) to Tp)		5°C /second max.
Preheat	Temperature Min (Ts(min))	150°C
	Temperature Max (Ts(max))	200°C
Time (Min to Max) (ts)		60-120 seconds
Reflow	Temperature (TL)	220°C
	Time Max (tL)	60 seconds
Peak Temperature(Tp)		260°C max
Ramp-down Rate		5°C/second max
Time 25°C to peak Temperature (Tp)		8 minutes max

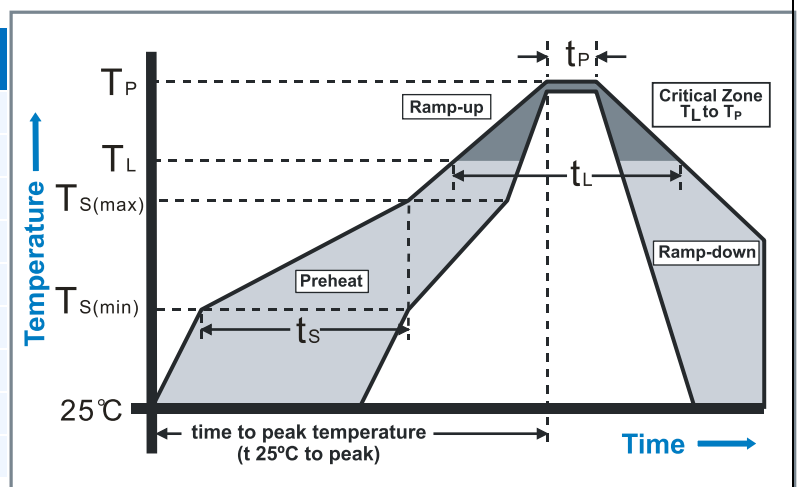

B. Hand-Solder Parameters:

Solder Iron Temperature: 300 ± 5°C

Heating Time: 1~2 s Max

9. Packaging

1,000 pcs in 7 inches dia. reel, 12mm wide tape, EIA Standard 481

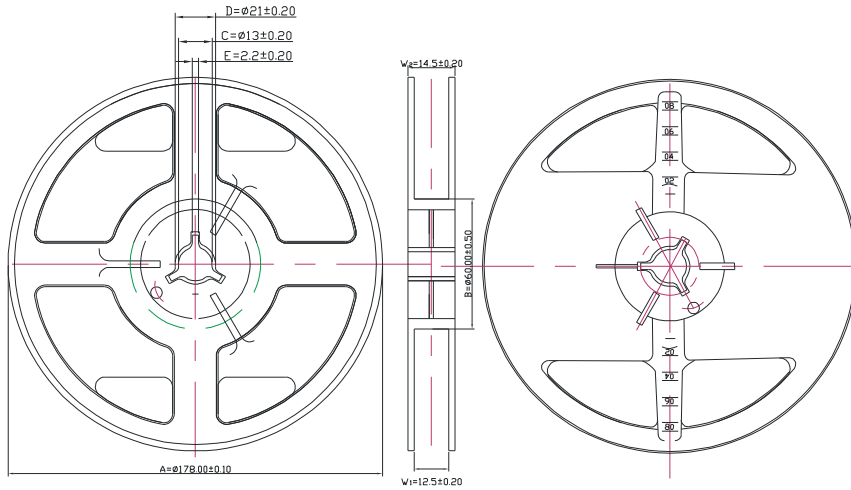

Item	A	B	C	D	E	W1	W2
Spec.(mm)	178±0.10	60±0.50	13±0.20	21±0.20	2.2±0.20	12.5±0.20	14.5±0.20

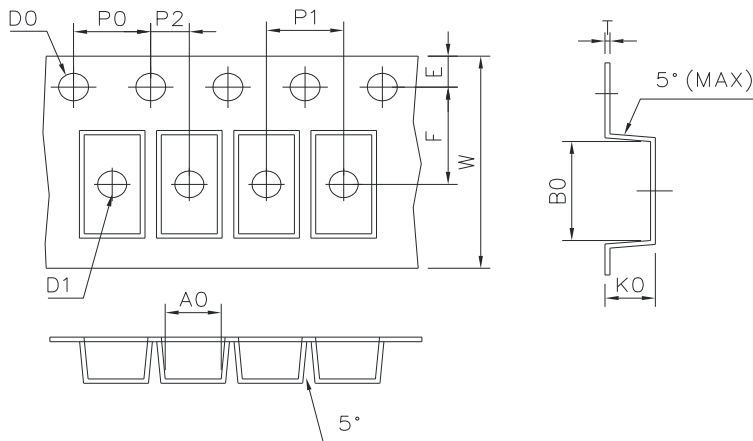

Item	A_0	B_0	D_0	D_1	E	F
Spec.(mm)	2.70±0.10	6.40±0.10	1.50±0.10	1.50±0.25	1.75±0.10	5.50±0.10
Item	K_0	P_0	P_1	P_2	W	t
Spec.(mm)	2.70±0.10	4.00±0.10	4.00±0.10	2.00±0.10	12.00±0.15	0.25±0.05