



**DC COMPONENTS CO., LTD.**  
RECTIFIER SPECIALISTS

KBPC10005  
THRU  
KBPC1010

**TECHNICAL SPECIFICATIONS OF SINGLE-PHASE SILICON BRIDGE RECTIFIER**  
VOLTAGE RANGE - 50 to 1000 Volts  
CURRENT - 10 Amperes

**FEATURES**

- \* Surge overload rating: 200 Amperes peak
- \* Low forward voltage drop

**MECHANICAL DATA**

- \* Case: Molded plastic
- \* Epoxy: UL 94V-0 rate flame retardant
- \* Lead: MIL-STD-202E, Method 208 guaranteed
- \* Polarity: As marked
- \* Mounting position: Any
- \* Weight: 6.9 grams

**MAXIMUM RATINGS AND ELECTRICAL CHARACTERISTICS**

Ratings at 25 °C ambient temperature unless otherwise specified.  
Single phase, half wave, 60 Hz, resistive or inductive load.  
For capacitive load, derate current by 20%.



KBPC-8/10

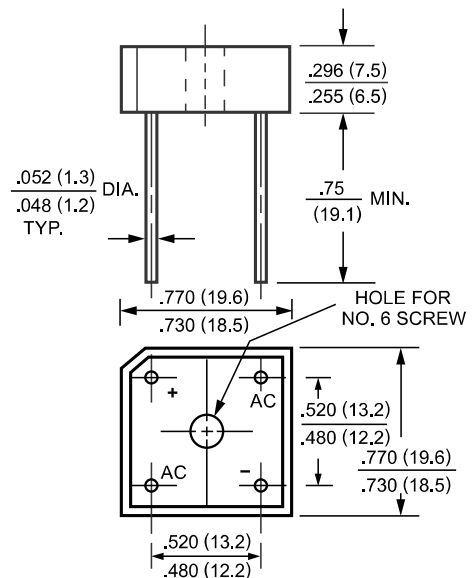

Dimensions in inches and (millimeters)

	SYMBOL	KBPC 10005	KBPC 1001	KBPC 1002	KBPC 1004	KBPC 1006	KBPC 1008	KBPC 1010	UNITS
Maximum Recurrent Peak Reverse Voltage	V <sub>RRM</sub>	50	100	200	400	600	800	1000	Volts
Maximum RMS Voltage	V <sub>RMS</sub>	35	70	140	280	420	560	700	Volts
Maximum DC Blocking Voltage	V <sub>DC</sub>	50	100	200	400	600	800	1000	Volts
Maximum Average Forward Rectified Output Current at T <sub>c</sub> = 50°C	I <sub>O</sub>	10							Amps
Peak Forward Surge Current 8.3 ms single half sine-wave superimposed on rated load (JEDEC Method)	I <sub>FSM</sub>	200							Amps
Maximum Forward Voltage Drop per element at 5.0A DC	V <sub>F</sub>	1.1							Volts
Maximum DC Reverse Current at Rated	I <sub>R</sub>	@T <sub>A</sub> = 25°C							uAmps
DC Blocking Voltage per element		@T <sub>C</sub> = 100°C							
I <sup>2</sup> t Rating for Fusing (t<8.3ms)	I <sup>2</sup> t	166							A <sup>2</sup> Sec
Typical Junction Capacitance ( Note1)	C <sub>J</sub>	200							pF
Typical Thermal Resistance (Note 2)	R <sub>θJA</sub>	21							°C/W
Operating Temperature Range	T <sub>J</sub>	-55 to + 125							°C
Storage Temperature Range	T <sub>STG</sub>	-55 to + 150							°C

NOTES : 1.Measured at 1 MHz and applied reverse voltage of 4.0 volts

2. Thermal Resistance from Junction to Ambient and from junction to lead mounted on P.C.B. with 0.5 x 0.5" (13x13mm) copper pads.



NEXT



BACK



EXIT

# RATING AND CHARACTERISTIC CURVES (KBPC10005 THRU KBPC1010)

FIG. 1 - MAXIMUM NON-REPETITIVE FORWARD SURGE CURRENT

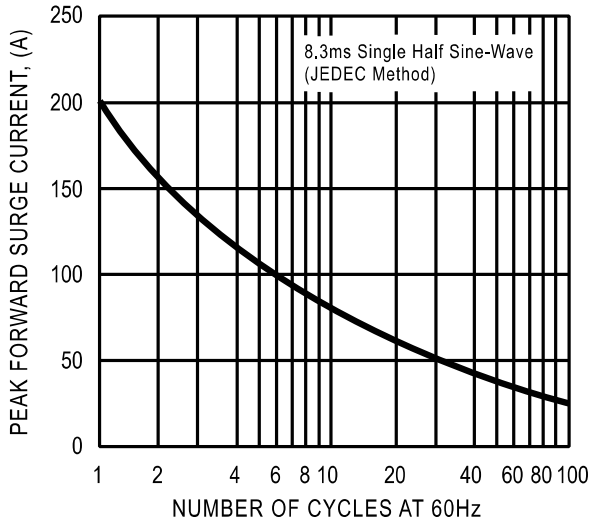

FIG. 2 - TYPICAL FORWARD CURRENT DERATING CURVE

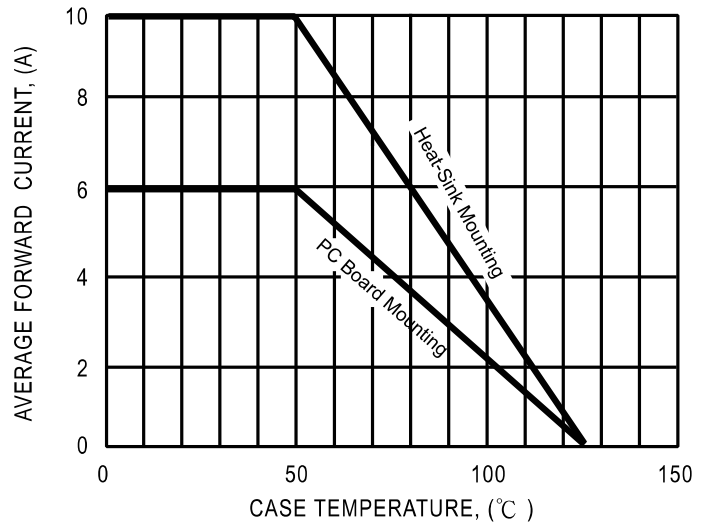

FIG. 3- TYPICAL INSTANTANEOUS FORWARD CHARACTERISTICS

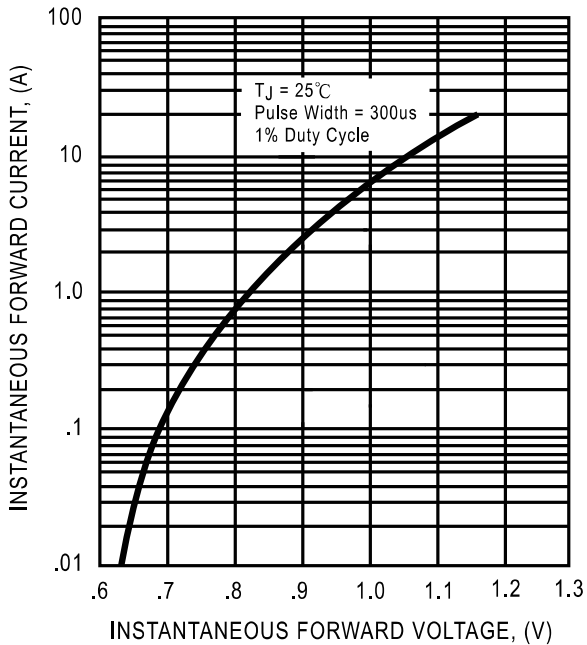
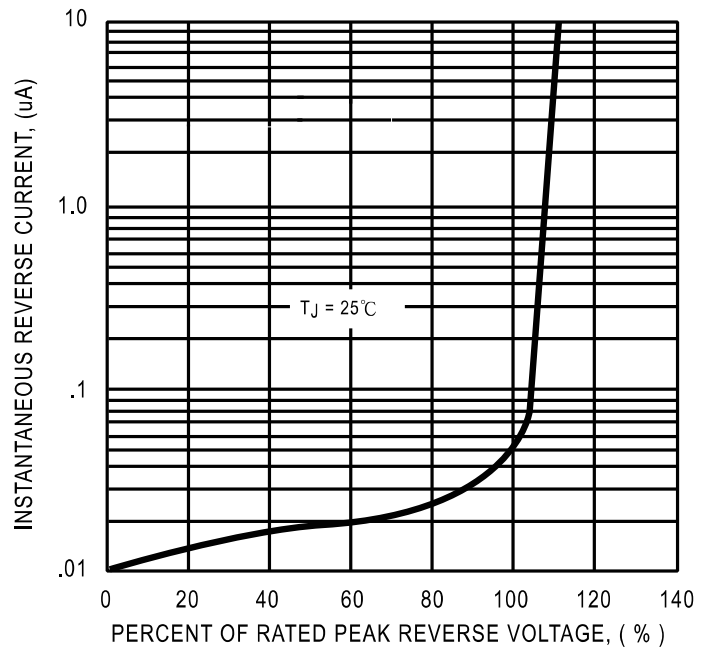

FIG. 4 - TYPICAL REVERSE CHARACTERISTICS



DC COMPONENTS CO., LTD.



NEXT



BACK



EXIT