



48 x 48mm

**Features :**

- 3+3 Digits, 7 Segment LED Dual Display
- TC / RTD Inputs
- ON - OFF / PID Control
- Auto Tuning / Self Tuning
- Single Set Point
- °C / °F Selectable
- Field selectable Control Output (Relay or SSR)

Certifications :

**Display Specifications**

Display	3+3 Digits 7 Segment LED Dual Display Height of Upper Display : 10mm Height of Lower Display : 7mm
LED Indications	R : Control output ON

**Input Specifications**

Inputs	Thermocouple (J, K, T, R, S) / RTD (Pt100)
Resolution	Fixed 1°
Indication Accuracy	For J, K & T inputs : 0.25% of F.S. ±1°C For R & S inputs : 0.5% of F.S. ±2°C (20 min of warm up time for TC inputs) For RTD inputs : 0.1% of F.S. ±1°C (F.S. = Full Scale)
Temperature Unit	°C / °F selectable
Input Filter (FTC)	0.2 to 10.0 Sec
Sampling time	250 msec

**Output Specifications**

Relay Contact (SPDT)	10A resistive @ 250V AC / 30V DC
SSR Drive (Voltage Pulse)	12V DC, 50mA

**Functional Specifications**

Control Action	1) PID Control with Auto or self tuning 2) ON - OFF Control
Proportional Band (P)	1 to 400°C
Integral Time (I)	0.0 to 99.9 Min
Derivative Time (D)	0 to 999 Sec
Cycle Time	0.1 to 99.9 Sec
Hysteresis Width	0.1 to 99.9°
Manual Reset Value	-19.9 to 19.9°C

**Auxiliary Supply Specifications**

Supply Voltage	90 to 270V AC / DC (50 / 60Hz)
Power Consumption	6 VA max @ 230V AC

**Environmental Specifications**

Temperature	Operating : 0 to 50°C (32 to 122°F) Storage : 20 to 75°C (-4 to 167°F)
Humidity (non - condensing)	95% RH

**Mechanical Specifications**

Mounting	Panel
Weight	110 gms

**Dimensions**

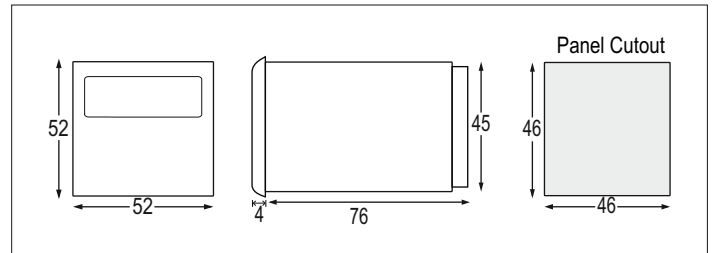

**Terminal Connections**

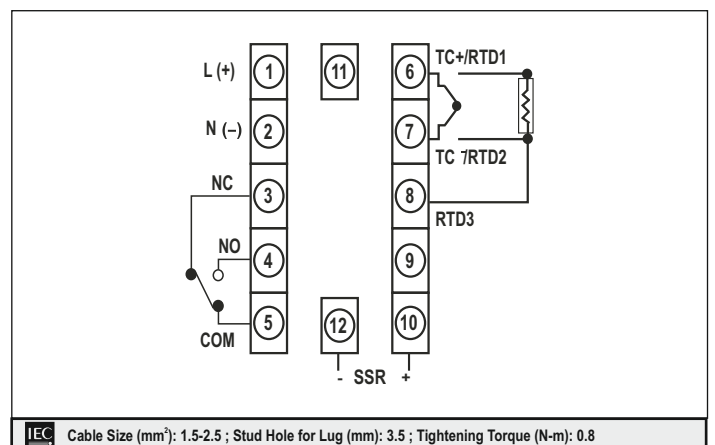

Cable Size (mm<sup>2</sup>): 1.5-2.5 ; Stud Hole for Lug (mm): 3.5 ; Tightening Torque (N-m): 0.8

Compliance

Applicable EMI / EMC Standards		
Product Standard : IEC 61326-1		
Category		Standards Compliance
ESD Immunity	IEC 61000-4-2	Level III
Surge Immunity	IEC 61000-4-5	+/- 2 kV common mode, +/- 1 kV differential mode
Radiated Susceptibility	IEC 61000-4-3	Level III, 80 to 1000MHz Level II, 1.4GHz to 2GHz Level I, 2GHz to 2.7GHz
Conducted Susceptibility	IEC 61000-4-6	Level II
Voltage Dips and Interruptions	IEC 61000-4-11	<b>Dips</b> : 0% residual voltage / 1 cycle (Criteria B), 40% residual voltage / 10 cycles 50Hz / 12 cycles 60Hz (Criteria C) 70% residual voltage / 25 cycles 50Hz / 30 cycles 60Hz (Criteria C) <b>Interruptions</b> : 0% residual voltage / 250 cycles 50Hz / 300 cycles 60Hz (Criteria C)
Conducted Emission	CISPR-11	
Radiated Emission	CISPR-11	
Electrical Fast Transient	IEC 61000-4-4	Level III

Ordering Information

PRODUCT CODE	OUTPUT 1		SUPPLY VOLTAGE	CERTIFICATION
TC533BX	Relay	SSR	90 - 270VAC / DC	--
TC533BX-CE	Relay	SSR	90 - 270VAC / DC	CE

Accessories ( Optional )

Standard SELEC accessories that can be used with this product.

Adapter plate
1) AP7248 : Plastic adapter plate, used to mount 1 / 16 DIN (cutout size 48 x 48) Instrument into existing (72 x 72) cutout size.
2) AP9648 : Plastic adapter plate, used to mount 1 / 16 DIN (cutout size 48 x 48) Instrument into existing (96 x 96) cutout size.
3) AP4896-4848-G-C : Plastic adapter plate, used to mount 1 / 16 DIN (cutout size 48 x 48) Instrument into existing (48 x 96) cutout size.

Mounting Accessories (Supplied with units)

For 48 X 48 Collar clamp	ACL4802
--------------------------	---------

Input Sensor Ranges (For TC / RTD Inputs)

Sensor type	Resolution	Ranges
		1
PT100	°C	-150 to 850
	°F	-199 to 999
J	°C	-199 to 750
	°F	-199 to 999
K	°C	-199 to 999
	°F	-199 to 999
T	°C	-199 to 400
	°F	-199 to 750
R & S	°C	0 to 999
	°F	32 to 999