

# Lithium Manganese Dioxide Coin Battery : Individual Specification

## CR2016

Nominal Voltage	3V	<p style="text-align: center;">Dimensions (mm)</p> 	A	$\phi 17.5$
Nominal Capacity	75(mAh)		B	$\phi 20.0^{+0.0}_{-0.3}$
Continuous standard load	30(K $\Omega$ )		C	1.2
Operating temperature	-20~60 $^{\circ}$ C		D	$1.6^{+0.0}_{-0.3}$
Weight	2.0(g)			

### Discharge characteristics

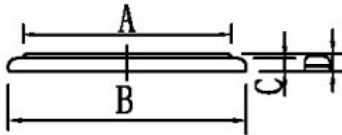
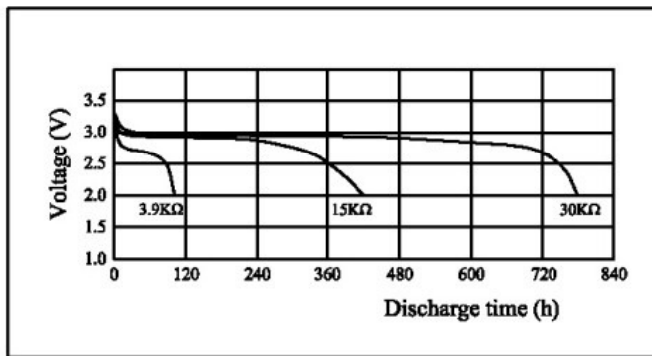

### Temperature characteristics

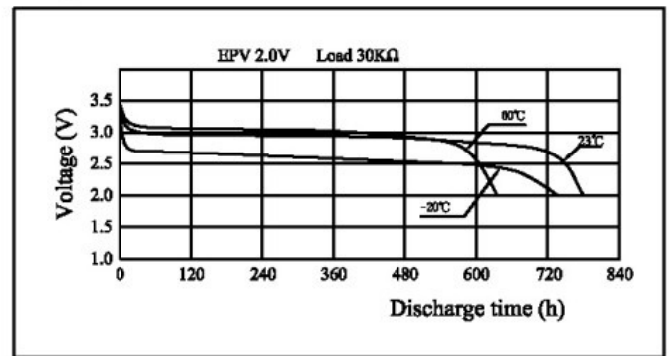

### Load vs. Operating voltage

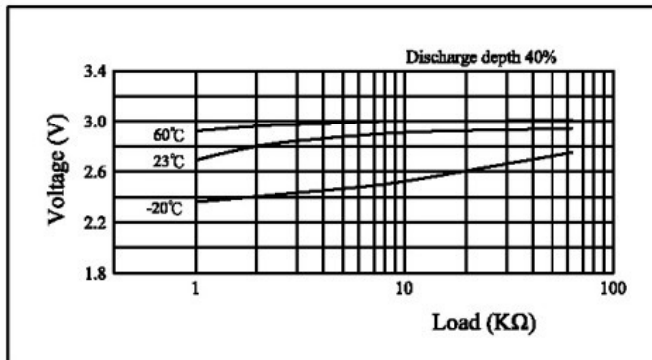

### Load vs. Capacity

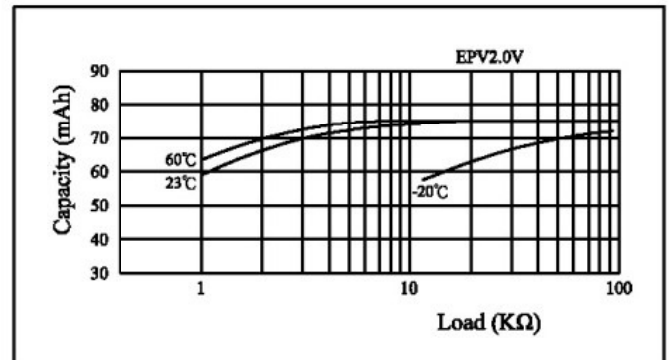

### Pulse discharge characteristics

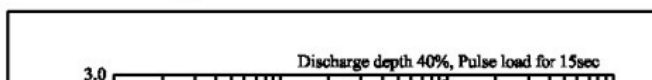

### Storage characteristics

