

NXH Series

• 105°C 6,000~10,000Hrs assured.

- Non-solvent proof.
- Low Impedance.
- Long Life.
- For LED TV BLU Inverter, SMPS, IP-Board, Adaptor.
- RoHS compliant.
- Halogen-free capacitors are also available.

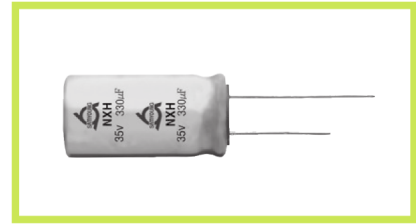

SPECIFICATIONS

Item	Characteristics																				
Rated Voltage Range	6.3 ~ 100 V _{DC}																				
Operating Temperature Range	-40 ~ +105°C																				
Capacitance Tolerance	±20%(M) (at 20°C, 120Hz)																				
Leakage Current	I=0.01CV(μA) or 3μA, whichever is greater. Where, I:Max. Leakage current(μA), C:Nominal capacitance(μF), V:Rated voltage(V _{DC}) (at 20°C, 2 minutes)																				
Dissipation Factor(Tanδ)	<table border="1"> <tr> <td>Rated voltage(V_{DC})</td> <td>6.3</td> <td>10</td> <td>16</td> <td>25</td> <td>35</td> <td>50</td> <td>63</td> <td>80</td> <td>100</td> </tr> <tr> <td>Tanδ(Max.)</td> <td>0.22</td> <td>0.19</td> <td>0.16</td> <td>0.14</td> <td>0.12</td> <td>0.10</td> <td>0.09</td> <td>0.08</td> <td>0.08</td> </tr> </table> <p>When the capacitance exceeds 1,000μF, 0.02 shall be added every 1,000μF increase. (at 20°C, 120Hz)</p>	Rated voltage(V _{DC})	6.3	10	16	25	35	50	63	80	100	Tanδ(Max.)	0.22	0.19	0.16	0.14	0.12	0.10	0.09	0.08	0.08
Rated voltage(V _{DC})	6.3	10	16	25	35	50	63	80	100												
Tanδ(Max.)	0.22	0.19	0.16	0.14	0.12	0.10	0.09	0.08	0.08												
Temperature Characteristics (Max. Impedance ratio)	<table border="1"> <tr> <td>Z(-25°C)/Z(+20°C)</td> <td>2</td> </tr> <tr> <td>Z(-40°C)/Z(+20°C)</td> <td>3</td> </tr> </table> <p>(at 120Hz)</p>	Z(-25°C)/Z(+20°C)	2	Z(-40°C)/Z(+20°C)	3																
Z(-25°C)/Z(+20°C)	2																				
Z(-40°C)/Z(+20°C)	3																				
Load Life	<p>The following specifications shall be satisfied when the capacitors are restored to 20°C after the rated voltage with the rated ripple current is applied (the peak voltage shall not exceed the rated voltage) at 105°C for the specified period of time.</p> <table border="1"> <tr> <td>Rated voltage(V_{DC})</td> <td>6.3~10</td> <td>16~100</td> <td>∅D</td> <td>Life Time</td> </tr> <tr> <td>Capacitance change</td> <td>≤±30% of the initial value</td> <td>≤±25% of the initial value</td> <td>∅5~∅6.3</td> <td>6,000 hours</td> </tr> <tr> <td>Tan δ</td> <td colspan="2">≤200% of the initial specified value</td> <td>∅8</td> <td>8,000 hours</td> </tr> <tr> <td>Leakage current</td> <td colspan="2">≤The initial specified value</td> <td>∅10~</td> <td>10,000 hours</td> </tr> </table>	Rated voltage(V _{DC})	6.3~10	16~100	∅D	Life Time	Capacitance change	≤±30% of the initial value	≤±25% of the initial value	∅5~∅6.3	6,000 hours	Tan δ	≤200% of the initial specified value		∅8	8,000 hours	Leakage current	≤The initial specified value		∅10~	10,000 hours
Rated voltage(V _{DC})	6.3~10	16~100	∅D	Life Time																	
Capacitance change	≤±30% of the initial value	≤±25% of the initial value	∅5~∅6.3	6,000 hours																	
Tan δ	≤200% of the initial specified value		∅8	8,000 hours																	
Leakage current	≤The initial specified value		∅10~	10,000 hours																	
Shelf Life	<p>The following specifications shall be satisfied when the capacitors are restored to 20°C after exposing them for 1,000 hours at 105°C without voltage applied. The rated voltage shall be applied to the capacitors for a minimum of 30 minutes, at least 24 hours and not more than 48 hours before the measurements.</p> <table border="1"> <tr> <td>Rated voltage(V_{DC})</td> <td>6.3~10</td> <td>16~100</td> </tr> <tr> <td>Capacitance change</td> <td>≤±30% of the initial value</td> <td>≤±25% of the initial value</td> </tr> <tr> <td>Tan δ</td> <td colspan="2">≤200% of the initial specified value</td> </tr> <tr> <td>Leakage current</td> <td colspan="2">≤The initial specified value</td> </tr> </table>	Rated voltage(V _{DC})	6.3~10	16~100	Capacitance change	≤±30% of the initial value	≤±25% of the initial value	Tan δ	≤200% of the initial specified value		Leakage current	≤The initial specified value									
Rated voltage(V _{DC})	6.3~10	16~100																			
Capacitance change	≤±30% of the initial value	≤±25% of the initial value																			
Tan δ	≤200% of the initial specified value																				
Leakage current	≤The initial specified value																				
Others	Satisfied characteristics KS C IEC 60384-4																				

DIMENSIONS OF NXH Series

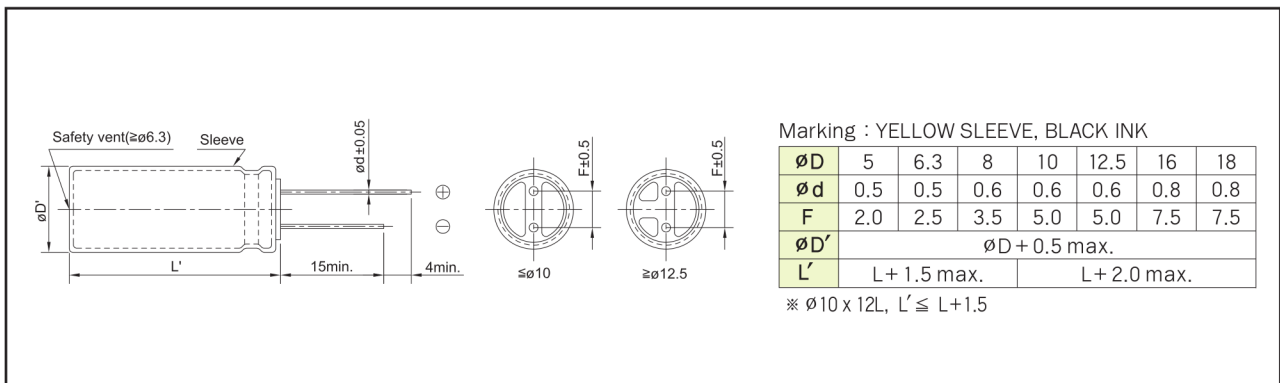

RATINGS OF NXH Series

V _{DC} ∅D×L(mm)	6.3				10				16			
	μF	IMP.		Ripple	μF	IMP.		Ripple	μF	IMP.		Ripple
		20°C	-10°C			20°C	-10°C			20°C	-10°C	
5 × 11	220	0.22	0.80	345	150	0.22	0.80	345	100	0.22	0.80	345
5 × 15	470	0.13	0.47	480	330	0.13	0.47	480	220	0.13	0.47	480
6.3 × 11	470	0.094	0.35	540	330	0.094	0.35	540	220	0.094	0.35	540
6.3 × 15	560	0.084	0.31	620	470	0.084	0.31	620	330	0.084	0.31	620
8 × 11.5	820	0.056	0.19	945	680	0.056	0.19	945	470	0.056	0.19	945
8 × 15	1,200	0.045	0.15	1,250	1,000	0.045	0.15	1,250	680	0.045	0.15	1,250
8 × 20	1,500	0.029	0.11	1,500	1,500	0.029	0.11	1,500	1,000	0.029	0.11	1,500
10 × 12	1,200	0.039	0.14	1,330	1,000	0.039	0.14	1,330	680	0.039	0.14	1,330
10 × 12.5	1,200	0.039	0.14	1,330	1,000	0.039	0.14	1,330	680	0.039	0.14	1,330
10 × 16	1,800	0.028	0.10	1,760	1,500	0.028	0.10	1,760	1,000	0.028	0.10	1,760
10 × 20	2,200	0.020	0.060	1,960	1,800	0.020	0.060	1,960	1,500	0.020	0.060	1,960
10 × 25	2,700	0.018	0.054	2,250	2,200	0.018	0.054	2,250	1,800	0.018	0.054	2,250
10 × 33	3,300	0.015	0.045	2,550	2,700	0.015	0.045	2,550	2,200	0.015	0.045	2,550
12.5 × 20	3,900	0.017	0.043	2,480	3,300	0.017	0.043	2,480	2,200	0.017	0.043	2,480
12.5 × 25	4,700	0.015	0.038	2,900	3,900	0.015	0.038	2,900	2,700	0.015	0.038	2,900
12.5 × 30	5,600	0.013	0.033	3,450	4,700	0.013	0.033	3,450	3,300	0.013	0.033	3,450
12.5 × 35	6,800	0.012	0.031	3,570	5,600	0.012	0.031	3,570	3,900	0.012	0.031	3,570
16 × 20	6,800	0.015	0.038	3,250	4,700	0.015	0.038	3,250	3,300	0.015	0.038	3,250
16 × 25	8,200	0.013	0.035	3,630	6,800	0.013	0.035	3,630	4,700	0.013	0.035	3,630
18 × 25	10,000	0.012	0.031	3,650	8,200	0.012	0.031	3,650	5,600	0.012	0.031	3,650

V _{DC} ∅D×L(mm)	25				35				50			
	μF	IMP.		Ripple	μF	IMP.		Ripple	μF	IMP.		Ripple
		20°C	-10°C			20°C	-10°C			20°C	-10°C	
5 × 11	68	0.22	0.80	345	47	0.22	0.80	345	2.2	2.5	8.68	120
									4.7	2.5	8.68	120
									10	1.0	3.47	145
									22	0.40	1.39	195
									27	0.34	1.18	238
5 × 15	150	0.13	0.47	480	100	0.13	0.47	480	56	0.16	0.56	350
6.3 × 11	150	0.094	0.35	540	100	0.094	0.35	540	33	0.20	0.71	320
									47	0.14	0.50	450
									56	0.14	0.50	450
6.3 × 15	220	0.084	0.31	620	150	0.084	0.31	620	100	0.12	0.43	586
8 × 11.5	330	0.056	0.19	945	220	0.056	0.19	945	100	0.074	0.22	724
8 × 15	390	0.045	0.15	1,250	270	0.045	0.15	1,250	120	0.061	0.18	950
	470	0.045	0.15	1,330								
8 × 20	560	0.029	0.11	1,500	390	0.029	0.11	1,500	180	0.046	0.14	1,190
					470	0.029		1,600				
10 × 12	470	0.039	0.14	1,330	330	0.039	0.14	1,330	68	0.070	0.21	750
									150	0.061	0.18	979
10 × 12.5	470	0.039	0.14	1,330	330	0.039	0.14	1,330	68	0.070	0.21	750
									150	0.061	0.18	979
10 × 16	680	0.028	0.10	1,760	470	0.028	0.10	1,760	220	0.042	0.12	1,370
10 × 20	820	0.020	0.060	1,960	560	0.020	0.060	1,960	270	0.030	0.090	1,580
	1,000	0.020	0.060	1,960	680	0.025	0.075	1,850				
10 × 25	1,000	0.018	0.054	2,250	680	0.018	0.054	2,250	330	0.028	0.085	1,870
10 × 33	1,200	0.015	0.045	2,550	1,000	0.015	0.045	2,550	470	0.025	0.076	2,110
12.5 × 20	1,000	0.018	0.045	2,500	1,000	0.017	0.043	2,480	470	0.027	0.068	2,050
	1,500	0.017	0.043	2,550								
12.5 × 25	1,800	0.015	0.038	2,900	1,200	0.015	0.038	2,900	560	0.023	0.059	2,410
12.5 × 30	2,200	0.013	0.033	3,450	1,500	0.013	0.033	3,450	680	0.021	0.052	2,860
12.5 × 35	2,700	0.012	0.031	3,570	1,800	0.012	0.031	3,570	820	0.019	0.051	2,960
16 × 20	2,200	0.015	0.038	3,250	1,500	0.015	0.038	3,250	820	0.023	0.059	2,730
	2,700	0.015	0.038	3,250					1,000	0.023	0.059	2,730
16 × 25	3,300	0.013	0.035	3,630	2,200	0.013	0.035	3,630	1,000	0.021	0.056	3,010
18 × 25	3,900	0.012	0.031	3,650	2,700	0.012	0.031	3,650	1,500	0.019	0.051	3,290

NXH Series



MINIATURE ALUMINUM ELECTROLYTIC CAPACITORS

RATINGS OF NXH Series

∅D×L(mm)	V _{DC}			
	μF	63		Ripple
		20°C	-10°C	
5×11	18	0.45	1.8	173
6.3×11	47	0.30	1.2	278
8×11.5	82	0.20	0.80	525
8×15	100	0.18	0.72	688
8×20	150	0.16	0.64	861
10×12	120	0.16	0.64	725
10×12.5	120	0.16	0.64	725
10×16	180	0.10	0.40	998
10×20	270	0.080	0.32	1,200
10×25	330	0.070	0.28	1,410
12.5×20	390	0.050	0.20	1,570
12.5×25	470	0.037	0.15	1,990
12.5×30	560	0.032	0.13	2,410
12.5×35	680	0.030	0.12	2,620
16×20	560	0.035	0.14	2,100
16×25	820	0.030	0.12	2,430

∅D×L(mm)	V _{DC}				V _{DC}			
	μF	80		Ripple	μF	100		Ripple
		20°C	-10°C			20°C	-10°C	
5×11	12	1.2	5.33	163	8.2	1.2	5.33	163
6.3×11	33	0.46	2.03	267	18	0.46	2.03	267
8×11.5	56	0.29	1.31	462	33	0.29	1.31	462
8×15	68	0.20	0.90	585	47	0.20	0.90	585
8×20	100	0.16	0.72	735	68	0.16	0.72	735
10×12	82	0.17	0.68	624	47	0.17	0.68	624
10×12.5	82	0.17	0.68	624	47	0.17	0.68	624
10×16	120	0.11	0.44	780	68	0.11	0.44	780
10×20	180	0.084	0.35	1,040	100	0.084	0.35	1,040
10×25	220	0.069	0.28	1,170	120	0.069	0.28	1,170
12.5×16	180	0.11	0.33	975	100	0.11	0.33	975
12.5×20	270	0.062	0.19	1,430	150	0.062	0.19	1,430
12.5×25	330	0.047	0.15	1,620	220	0.047	0.15	1,620
12.5×30	390	0.042	0.14	1,950	270	0.042	0.14	1,950
12.5×35	470	0.036	0.11	2,140	330	0.036	0.11	2,140
12.5 x 40	560	0.032	0.096	2,340	390	0.032	0.096	2,340
16×20	390	0.048	0.16	1,750	270	0.048	0.16	1,750
16×25	560	0.038	0.11	2,210	390	0.038	0.11	2,210
16×31.5	680	0.032	0.096	2,400	470	0.032	0.096	2,400
16×35.5	820	0.029	0.087	2,600	560	0.029	0.087	2,600
16×40	1,000	0.027	0.081	2,860	680	0.027	0.081	2,860
18×20	560	0.045	0.14	1,950	390	0.045	0.14	1,950
18×25	820	0.036	0.11	2,270	470	0.036	0.11	2,270
18×31.5	1,000	0.030	0.090	2,470	560	0.030	0.090	2,470
18×35.5	1,200	0.027	0.081	2,860	680	0.027	0.081	2,860
18×40	1,500	0.026	0.078	3,510	820	0.026	0.078	3,510

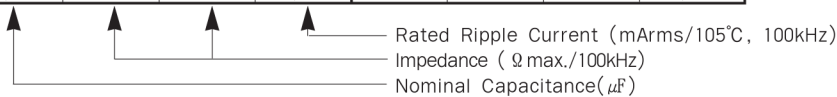

RIPPLE CURRENT MULTIPLIERS

Frequency Multipliers

Cap.(μF)	Freq.(Hz)	120	1k	10k	50k	100k
2.2 ~ 22		0.40	0.66	0.85	0.90	1.00
27 ~ 33		0.42	0.70	0.90	0.93	1.00
39 ~ 270		0.50	0.73	0.92	0.95	1.00
330 ~ 680		0.55	0.77	0.94	0.96	1.00
820 ~ 1,800		0.60	0.80	0.96	0.97	1.00
2,200 ~ 10,000		0.70	0.85	0.98	0.99	1.00