

TRIHERO

Digital Temperature Controller

CHD series

Economy Version

Standard Four digits PID



- Selectable input(TC,RTD,Analog)
- PID with auto-tuning
- Accuracy 0.5%F.S
- 90~260 VAC,24VDC power supply optional
- SSR drive/Relay/4-20mA/Thyristor trigger output
- Dual line four digits display
- Panel mount
- Auxiliary power supply for sensors optional

Panel Description

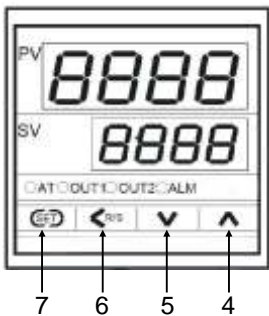

- 1:Process value or parameter display
- 2:Setting value or parameter value display
- 3:Indication lamps
AT---Auto-tuning lamps
OUT1---For output 1 indication
OUT2---For output 2 indication
ALM ---For first stage alarm indication
- 4:Increase key
- 5:Decrease key
- 6:Shift key or Run/Stop key
- 7:Set key

Ordering Information

CHD -

1 2 3 4

1:Size Information

- 102:** 48mm(Width)*48mm(Height)
- 402:** 48mm(Width)*96mm(Height)
- 702:** 72mm(Width)*72mm(Height)
- 902:** 96mm(Width)*96mm(Height)
- 502:** 96mm(Width)*48mm(Height)

2:Output

- R:** Relay
- V:** SSR drive
- D:** 4-20mA
- A:** Single-phase thyristor zero crossing trigger output

3:Power Supply

- 1:** 90~260VAC
- 2:** 24VDC

4:Auxiliary Power supply for transducer

- 1:** 24VDC
- N:** Without auxiliary power supply

*Remark:Auxiliary power supply are not available for size 48mm*48mm controller*

Specifications

Power Supply	:90~260VAC/24DC
Power Consumption	:5 VA(Maximum)
Display	:Dual Line four digits.7 segments LED display
Control method	:P,PID,PI, PD,ON/OFF(P=0)
Input	:Thermocouple(K,J,R,S,B,E,N,T,U,L,PLII,W5Re/W26Re) RTD(Pt100, JPT100) Voltage and Current(0-5VDC,1-5VDC,0-20mADC,4-20mADC)
Output	:Relay(10A/220VAC) SSR DRIVE(12VDC 50mA max) Current output(4-20mA/0-10mA) Thyristor zero-crossing trigger(1A 500V)
Auxiliary output	:24VDC(48mm*48mm not available)
Measuring Accuracy	:0.5%F.S
Control Accuracy	:+/- 1 Celsious
Alarm output	:One stage alarm
Alarm mode	:Deviation high Deviation low Deviation high/low Band alarm Process high Process low
Proportional band(P)	:0.1-999.9/1-9999(default 30)
Integral time(I)	:1-3600S(default 240S)
Derivative times(D)	:1-3600S(default 60S)
Control Time(T)	:1-100S(default 20S for replay output, 2S for SSR drive and 4-20mA output)
Sampling time(T)	:0.5 second
Ambient Temperature	:0°C~50°C
Memory retention	:yes
Ambient humidity	:45%-85% RH(None Freeze)
Weight	:CHD- 102 (0.17kg) - 402 (0.22kg) - 502 (0.22kg) - 702 (0.22kg) - 902 (0.31kg)
Size and dimensions	:CHD-102 -48mm*48mm cutout(45mm*45mm*78mm) - 402 -48mm*96mm cutout(45mm*91.5mm*70mm) - 702 -72mm*72mm cutout(67.5mm*67.5mm*92mm) - 902 -96mm*96mm cutout(91.5mm*91.5mm*70mm) - 502 -96mm*48mm cutout(91.5mm*45mm*70mm)

Temperature Controller/Solid State Relay/Rotary Encoder

Input Signals

Thermocouple	:K(0°C-1372°C) J(0°C-1200°C) R(0°C-1769°C) S(0°C-1769°C) B(0°C-1820°C) E(0°C-1000°C) T(-199°C-400°C) N(0°C-1300°C) U(-199°C-600°C) L(0°C-900°C) PLII(0°C-1390°C) W5Re/W26Re(0°C-2320°C)
RTD	:PT100(-199.9°C-649.0°C) Jpt100(-199.9C-649.0°C)
Analog	:0-5VDC(-1999-9999 range configurable) 1-5VDC(-1999-9999 range configurable) 0-10mADC(-1999-9999 range configurable) 4-20mADC(-1999-9999 range configurable)

Remark:Be sure to parallel connect a 250 ohm to the input terminal when input is 0-10mA or 4-20mA

Terminal Arrangement

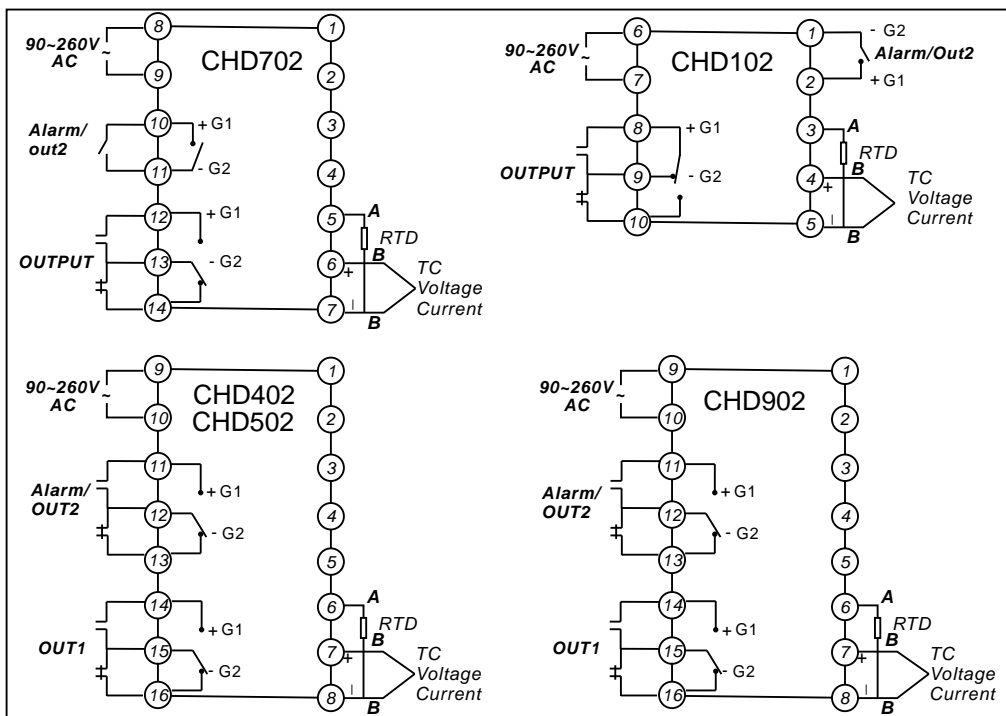

Remark:Parallel a 250 Ohm resistor to the input terminal when input is current(0-10mA/4-20mA)

Remark:G1 G2 for zero crossing thyristor trigger output

ADD-ON Features

Auxiliary Power Supply	:24VDC auxiliary power supply are available for all sizes except 48mm*48m controller, it is a great features when controller used for process control such as pressure controller, 24VDC can be a power source for pressure transducer.
10A Main output Relay	:The rating of Main output relay is 10A/250VAC controller can be connected to load directly if necessary when the actually load current less than 6A, it is more convenient than 3A relay.

Temperature Controller/Solid State Relay/Rotary Encoder