

TDA Series

• 105°C 2,000Hrs assured.

- Non-solvent proof.
- For SMPS, Inverter.
- RoHS compliant.
- Halogen-free capacitors are also available.



SPECIFICATIONS

Item	Characteristics																									
Rated Voltage Range	16 ~ 100 V _{DC}	160 ~ 500 V _{DC}																								
Operating Temperature Range	-40 ~ +105°C	-25 ~ +105°C																								
Capacitance Tolerance	±20% (M) (at 20°C, at 120Hz)																									
Leakage Current	I = 0.02CV(µA) or 3mA, whichever is smaller. Where, I:Max. leakage current(µA) C:Nominal capacitance(µF) V:Rated voltage(V _{DC}) (at 20°C, 5 minutes)																									
※ Dissipation Factor(Tanδ)	<table border="1"> <tr> <td>Rated Voltage(V_{DC})</td> <td>16</td> <td>25~35</td> <td>50~63</td> <td>100</td> <td>160~400</td> <td>420~500</td> </tr> <tr> <td>Tanδ(Max.)</td> <td>0.40</td> <td>0.35</td> <td>0.25</td> <td>0.20</td> <td>0.15</td> <td>0.20</td> </tr> </table> (at 20°C, 120Hz)		Rated Voltage(V _{DC})	16	25~35	50~63	100	160~400	420~500	Tanδ(Max.)	0.40	0.35	0.25	0.20	0.15	0.20										
Rated Voltage(V _{DC})	16	25~35	50~63	100	160~400	420~500																				
Tanδ(Max.)	0.40	0.35	0.25	0.20	0.15	0.20																				
Temperature Characteristics (Max.Impedance ratio)	<table border="1"> <tr> <td>Rated Voltage(V_{DC})</td> <td>16</td> <td>25</td> <td>35</td> <td>50~63</td> <td>100</td> <td>160~400</td> <td>420~500</td> </tr> <tr> <td>Z(-25°C)/Z(20°C)</td> <td>4</td> <td>3</td> <td>3</td> <td>2</td> <td>2</td> <td>4</td> <td>8</td> </tr> <tr> <td>Z(-40°C)/Z(20°C)</td> <td>15</td> <td>10</td> <td>8</td> <td>6</td> <td>5</td> <td>-</td> <td>-</td> </tr> </table> (at 120Hz)		Rated Voltage(V _{DC})	16	25	35	50~63	100	160~400	420~500	Z(-25°C)/Z(20°C)	4	3	3	2	2	4	8	Z(-40°C)/Z(20°C)	15	10	8	6	5	-	-
Rated Voltage(V _{DC})	16	25	35	50~63	100	160~400	420~500																			
Z(-25°C)/Z(20°C)	4	3	3	2	2	4	8																			
Z(-40°C)/Z(20°C)	15	10	8	6	5	-	-																			
Load Life	<p>The following specifications shall be satisfied when the capacitors are restored to 20°C after the rated voltage is applied for 2,000 hours at 105°C.</p> <p>Capacitance change ≤ ±20% of the initial value Tanδ ≤ 200% of the initial specified value Leakage Current ≤ The initial specified value</p>																									
Shelf Life	<p>The following specifications shall be satisfied when the capacitors are restored to 20°C after the exposing them at 105°C for 1,000 hours without voltage applied. The rated voltage shall be applied to the capacitors for a minimum of 30 minutes, at least 24 hours and not more than 48 hours before the measurements.</p> <p>Capacitance change ≤ ±20% of the initial value Tanδ ≤ 200% of the initial specified value Leakage Current ≤ The initial specified value</p>																									
Others	Satisfied characteristics KS C IEC 60384-4																									

※ For capacitors with CV products > 100,000 Higher Tanδ value may apply.
 When the capacitors exceed 1,000µF, 0.01 shall be added every 1,000µF increase.

RATED RIPPLE CURRENT

When capacitors are operated in any other condition at 120Hz, the maximum ripple current must be multiplied by the figure shown in the table.

Frequency multiplying factor

V _{DC}	Freq.(Hz)	60	120	300	1k	10k~
16~50V _{DC}		0.95	1.00	1.03	1.05	1.08
63~100V _{DC}		0.92	1.00	1.07	1.13	1.19
160~250V _{DC}		0.81	1.00	1.17	1.32	1.45
315~500V _{DC}		0.77	1.00	1.16	1.30	1.41

DIMENSIONS OF TDA Series

Unit(mm)

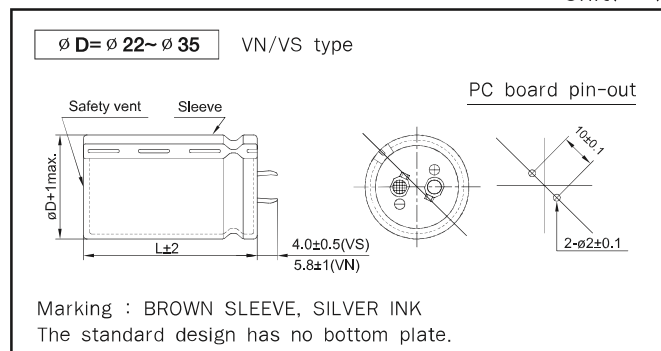

RATINGS OF TDA Series

μF \ V _{DC} / ∅ D	16				25				35			
	22	25.4	30	35	22	25.4	30	35	22	25.4	30	35
3,300									22 × 25 1.40			
3,900									22 × 30 1.57			
4,700					22 × 25 1.50				22 × 30 1.72	25.4 × 25 1.80		
5,600					22 × 25 1.63				22 × 35 1.95	25.4 × 30 1.96	30 × 25 1.99	
6,800	22 × 25 1.57				22 × 30 1.86	25.4 × 25 1.87			22 × 40 2.20	25.4 × 35 2.23	30 × 25 2.19	
8,200	22 × 30 1.73				22 × 35 2.11	25.4 × 30 2.12	30 × 25 2.15		22 × 50 2.55	25.4 × 40 2.53	30 × 30 2.53	
10,000	22 × 30 1.97	25.4 × 25 1.97			22 × 40 2.39	25.4 × 35 2.42	30 × 25 2.39			25.4 × 45 2.87	30 × 35 2.90	35 × 30 2.75
12,000	22 × 35 2.22	25.4 × 30 2.24			22 × 45 2.69	25.4 × 40 2.74	30 × 30 2.70	35 × 25 2.74		25.4 × 50 3.24	30 × 40 3.23	35 × 30 3.23
15,000	22 × 40 2.55	25.4 × 35 2.58				25.4 × 45 3.15	30 × 35 3.13	35 × 30 3.27			30 × 45 3.72	35 × 35 3.67
18,000	22 × 45 2.87	25.4 × 40 2.92	30 × 30 2.88			25.4 × 50 3.54	30 × 40 3.54	35 × 30 3.50				35 × 40 4.37
22,000		25.4 × 45 3.32	30 × 35 3.29				30 × 45 4.04	35 × 35 3.97				35 × 50 4.92
27,000		25.4 × 50 3.78	30 × 40 3.77	35 × 30 3.45				35 × 45 4.73				
33,000			30 × 45 4.30	35 × 35 4.26				35 × 50 5.39				
39,000			30 × 50 4.81	35 × 40 4.79								
47,000				35 × 50 5.43								

μF \ V _{DC} / ∅ D	50				63				100			
	22	25.4	30	35	22	25.4	30	35	22	25.4	30	35
560									22 × 25 1.06			
820									22 × 30 1.32	25.4 × 25 1.33		
1,000									22 × 35 1.50	25.4 × 30 1.51		
1,200					22 × 25 1.19				22 × 40 1.69	25.4 × 35 1.71	30 × 25 1.68	
1,500					22 × 25 1.33				22 × 45 1.94	25.4 × 40 1.98	30 × 30 1.95	
1,800	22 × 25 1.33				22 × 30 1.51	25.4 × 25 1.52				25.4 × 45 2.23	30 × 35 2.26	35 × 25 2.17
2,200	22 × 30 1.50				22 × 35 1.73	25.4 × 30 1.74				25.4 × 50 2.53	30 × 40 2.57	35 × 30 2.50
2,700	22 × 30 1.69	25.4 × 25 1.70			22 × 40 1.97	25.4 × 35 1.99	30 × 25 1.91				30 × 45 2.88	35 × 35 2.86
3,300	22 × 35 1.93	25.4 × 30 1.85			22 × 50 2.29	25.4 × 40 2.27	30 × 30 2.24				30 × 50 3.28	35 × 40 3.27
3,900	22 × 40 2.16	25.4 × 35 2.18	30 × 25 2.15			25.4 × 45 2.54	30 × 35 2.56	35 × 25 2.56				35 × 45 3.67
4,700	22 × 45 2.43	25.4 × 35 2.39	30 × 30 2.35	35 × 25 2.48		25.4 × 50 2.86	30 × 40 2.86	35 × 30 2.79				35 × 50 3.80
5,600	22 × 50 2.75	25.4 × 40 2.70	30 × 35 2.76	35 × 25 2.70			30 × 45 3.22	35 × 35 3.19				
6,800		25.4 × 50 3.30	30 × 40 3.30	35 × 30 3.25			30 × 50 3.66	35 × 40 3.64				
8,200			30 × 45 3.60	35 × 35 3.56				35 × 45 3.90				
10,000			30 × 50 4.04	35 × 40 4.03				35 × 50 4.40				
12,000				35 × 45 4.56	← Case Size ∅ D × L (mm) ← Rated Ripple Current (Arms/105°C, 120Hz)							



LARGE SIZED ALUMINUM ELECTROLYTIC CAPACITORS

RATINGS OF TDA Series

μF	V_{DC} ϕ D	160				200				250			
		22	25.4	30	35	22	25.4	30	35	22	25.4	30	35
100													
120											25.4 × 20 0.48		
150					22 × 20 0.53						25.4 × 20 0.59		
180					22 × 20 0.62	25.4 × 20 0.64				22 × 25 0.78	25.4 × 20 0.75		
220			25.4 × 20 0.66		22 × 25 0.70	25.4 × 20 0.70				22 × 30 0.96	25.4 × 25 0.95	30 × 20 0.93	
270			25.4 × 20 0.80		22 × 25 0.87	25.4 × 20 0.83				22 × 30 1.11	25.4 × 25 1.10	30 × 20 1.10	
330	22 × 25 1.20	25.4 × 20 1.10			22 × 30 1.20	25.4 × 25 1.21	30 × 20 1.20			22 × 35 1.20	25.4 × 30 1.20	30 × 25 1.26	35 × 20 1.17
390	22 × 30 1.30	25.4 × 25 1.29	30 × 20 1.19		22 × 30 1.28	25.4 × 25 1.27	30 × 25 1.25			22 × 40 1.45	25.4 × 35 1.49	30 × 25 1.44	35 × 25 1.49
470	22 × 30 1.36	25.4 × 25 1.39	30 × 20 1.31	35 × 20 1.35	22 × 35 1.41	25.4 × 30 1.41	30 × 25 1.50	35 × 20 1.30		22 × 45 1.53	25.4 × 35 1.50	30 × 30 1.57	35 × 25 1.57
560	22 × 35 1.46	25.4 × 30 1.51	30 × 25 1.54	35 × 20 1.41	22 × 45 1.56	25.4 × 35 1.53	30 × 30 1.57	35 × 25 1.52		22 × 50 1.77	25.4 × 40 1.74	30 × 30 1.73	35 × 25 1.72
680	22 × 40 1.66	25.4 × 30 1.65	30 × 25 1.68	35 × 20 1.69	22 × 45 1.73	25.4 × 35 1.69	30 × 30 1.74	35 × 25 1.72			25.4 × 50 1.84	30 × 35 1.94	35 × 30 1.97
820	22 × 45 1.99	25.4 × 30 1.95	30 × 30 2.00	35 × 25 1.91		25.4 × 45 1.99	30 × 35 2.00	35 × 30 2.04			25.4 × 60 2.20	30 × 40 2.10	35 × 35 1.98
1,000	22 × 50 2.18	25.4 × 40 2.14	30 × 30 2.15	35 × 25 2.17		25.4 × 50 2.21	30 × 40 2.23	35 × 35 2.30				30 × 50 2.31	35 × 40 2.30
1,200		25.4 × 45 2.39	30 × 35 2.37	35 × 30 2.41		25.4 × 60 2.57	30 × 45 2.53	35 × 35 2.57				30 × 60 2.50	35 × 45 2.43
1,500		25.4 × 60 2.87	30 × 40 2.74	35 × 35 2.79			30 × 50 3.01	35 × 40 2.99					35 × 50 2.80
1,800			30 × 45 3.14	35 × 35 3.11			30 × 60 3.47	35 × 45 3.38					
2,200			30 × 60 3.76	35 × 45 3.66				35 × 60 3.60					

μF	V_{DC} ϕ D	315				350				400			
		22	25.4	30	35	22	25.4	30	35	22	25.4	30	35
47										22 × 20 0.22			
68										22 × 25 0.51	25.4 × 20 0.46		
82	22 × 25 0.64				22 × 25 0.56					22 × 25 0.55	25.4 × 20 0.53		
100	22 × 30 0.68				22 × 25 0.67					22 × 30 0.67	25.4 × 25 0.67	30 × 20 0.60	
120	22 × 30 0.75	25.4 × 25 0.76			22 × 30 0.73	25.4 × 25 0.73				22 × 35 0.76	25.4 × 30 0.76	30 × 25 0.76	35 × 20 0.70
150	22 × 35 0.82	25.4 × 30 0.83			22 × 35 0.83	25.4 × 30 0.83	30 × 25 0.83			22 × 40 0.82	25.4 × 30 0.80	30 × 25 0.82	35 × 20 0.80
180	22 × 40 0.91	25.4 × 30 0.88	30 × 25 0.85		22 × 40 0.89	25.4 × 30 0.89	30 × 25 0.91			22 × 45 0.88	25.4 × 35 0.88	30 × 30 0.89	35 × 25 0.90
220	22 × 45 0.94	25.4 × 35 0.96	30 × 30 1.00		22 × 45 0.98	25.4 × 35 0.98	30 × 30 0.98	35 × 25 0.96		22 × 50 1.01	25.4 × 40 0.99	30 × 30 0.98	35 × 25 1.02
270		25.4 × 45 1.13	30 × 35 1.12	35 × 25 1.06	22 × 50 1.12	25.4 × 40 1.10	30 × 30 1.08	35 × 25 1.12			25.4 × 45 1.12	30 × 35 1.12	35 × 30 1.16
330		25.4 × 50 1.28	30 × 40 1.28	35 × 30 1.30		25.4 × 45 1.24	30 × 40 1.24	35 × 30 1.29			25.4 × 50 1.27	30 × 40 1.28	35 × 35 1.35
390			30 × 45 1.44	35 × 35 1.42		25.4 × 60 1.47	30 × 40 1.40	35 × 35 1.47			25.4 × 60 1.51	30 × 45 1.49	35 × 35 1.47
470			30 × 50 1.63	35 × 40 1.64		25.4 × 60 1.70	30 × 45 1.67	35 × 35 1.65				30 × 50 1.63	35 × 40 1.62
560				35 × 45 1.87			30 × 50 1.87	35 × 40 1.86				30 × 60 1.88	35 × 50 1.88
680				35 × 50 2.07			30 × 60 2.18	35 × 50 2.18					35 × 60 2.19
820								35 × 60 2.53					

← Case Size ϕ D × L (mm)
← Rated Ripple Current (Arms/105°C, 120Hz)

RATINGS OF TDA Series

μF	V_{DC} ϕD	420				450				500			
		22	25.4	30	35	22	25.4	30	35	22	25.4	30	35
56						22 × 25 0.40				22 × 35 0.46	25.4 × 30 0.46	30 × 30 0.48	
68		22 × 25 0.50				22 × 30 0.50	25.4 × 25 0.50			22 × 40 0.53	25.4 × 35 0.53	30 × 30 0.55	
82		22 × 25 0.51	25.4 × 25 0.63			22 × 30 0.55	24.5 × 25 0.54			22 × 45 0.56	25.4 × 35 0.58	30 × 35 0.58	
100		22 × 30 0.58	25.4 × 30 0.69			22 × 35 0.62	25.4 × 30 0.62	30 × 25 0.64			25.4 × 40 0.65	30 × 35 0.66	
120		22 × 35 0.72	25.4 × 30 0.73	30 × 25 0.75		22 × 40 0.70	25.4 × 35 0.71	30 × 30 0.72	35 × 25 0.73		25.4 × 45 0.75	30 × 40 0.76	35 × 30 0.78
150		22 × 45 0.79	25.4 × 35 0.74	30 × 25 0.75	35 × 25 0.81	22 × 45 0.77	25.4 × 40 0.75	30 × 30 0.74	35 × 25 0.75			30 × 45 0.80	35 × 35 0.81
180		22 × 50 0.89	25.4 × 40 0.89	30 × 30 0.88	35 × 25 0.87		25.4 × 45 0.84	30 × 35 0.87	35 × 30 0.88			30 × 50 0.90	35 × 40 0.93
220			25.4 × 45 1.01	30 × 35 1.00	35 × 30 1.05		25.4 × 50 0.98	30 × 40 0.98	35 × 30 1.00			30 × 60 1.10	35 × 45 1.11
270				30 × 45 1.19	35 × 35 1.19		25.4 × 60 1.17	30 × 45 1.15	35 × 35 1.17				35 × 50 1.28
330				30 × 50 1.36	35 × 40 1.39			30 × 50 1.38	35 × 40 1.38				35 × 60 1.50
390					35 × 45 1.57			30 × 60 1.60	35 × 45 1.56				
470					35 × 50 1.73				35 × 50 1.72				
560									35 × 60 1.98	← Case Size $\phi D \times L$ (mm) ← Rated Ripple Current(Arms/105°C, 120Hz)			