



■ Features

- Universal AC input / Full range
- Protections: Short circuit / Overload / Over voltage / Over temperature
- Cooling by free air convection
- Can be installed on DIN rail TS-35/7.5 or 15
- UL 508 (industrial control equipment) approved
- EN61000-6-2(EN50082-2) industrial immunity level
- 100% full load burn-in test
- 2 years warranty

■ Description

EDR-120 is one economical slim 120W DIN rail power supply series, adapt to be installed on TS-35/7.5 or TS-35/15 mounting rails. The body is designed 40mm in width, which allows space saving inside the cabinets. The entire series adopts the full range AC input from 90VAC to 264VAC and conforms to EN61000-3-2, the norm the European Union regulates for harmonic current.

EDR-120 is designed with metal housing that enhances the unit's power dissipation. With working efficiency up to 88.5%, the entire series can operate at the ambient temperature between -20°C and 60°C under air convection. It is equipped with constant current mode for over-load protection, fitting various inductive or capacitive applications. The complete protection functions and relevant certificates for industrial control apparatus (UL508, TUV EN60950-1, and etc.) make EDR-120 a very competitive power supply solution for industrial applications.

■ Model Encoding

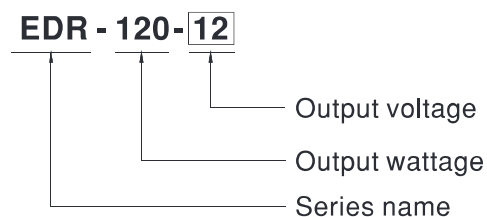

■ Applications

- Industrial control system
- Semiconductor fabrication equipment
- Factory automation
- Electro-mechanical apparatus

SPECIFICATION

| MODEL | | EDR-120-12 | EDR-120-24 | EDR-120-48 |
|-----------------------|--|---|--|------------|
| OUTPUT | DC VOLTAGE | 12V | 24V | 48V |
| | RATED CURRENT | 10A | 5A | 2.5A |
| | CURRENT RANGE | 0 ~ 10A | 0 ~ 5A | 0 ~ 2.5A |
| | RATED POWER | 120W | 120W | 120W |
| | RIPPLE & NOISE (max.) Note.2 | 100mVp-p | 120mVp-p | 150mVp-p |
| | VOLTAGE ADJ. RANGE | 12 ~ 14V | 24 ~ 28V | 48 ~ 55V |
| | VOLTAGE TOLERANCE Note.3 | ±2.0% | ±1.0% | ±1.0% |
| | LINE REGULATION | ±0.5% | ±0.5% | ±0.5% |
| | LOAD REGULATION | ±1.0% | ±1.0% | ±1.0% |
| | SETUP, RISE TIME | 1200ms, 60ms/230VAC 2500ms, 60ms/115VAC at full load | | |
| HOLD UP TIME (Typ.) | 16ms/230VAC 10ms/115VAC at full load | | | |
| INPUT | VOLTAGE RANGE Note.6 | 90 ~ 264VAC 127 ~ 370VDC | [DC input operation possible by connecting AC/L(+), AC/N(-)] | |
| | FREQUENCY RANGE | 47 ~ 63Hz | | |
| | EFFICIENCY (Typ.) | 85% | 87.5% | 88.5% |
| | AC CURRENT (Typ.) | 2.25A/115VAC 1.3A/230VAC | | |
| | INRUSH CURRENT (Typ.) | 20A/115VAC 35A/230VAC | | |
| | LEAKAGE CURRENT | <1mA / 240VAC | | |
| PROTECTION | OVERLOAD | 105 ~ 130% rated output power Protection type : Constant current limiting, recovers automatically after fault condition is removed | | |
| | OVER VOLTAGE | 14 ~ 17V | 29 ~ 33V | 56 ~ 65V |
| | OVER TEMPERATURE | Shut down o/p voltage, re-power on to recover | | |
| ENVIRONMENT | WORKING TEMP. | -20 ~ +60°C (Refer to "Derating Curve") | | |
| | WORKING HUMIDITY | 20 ~ 95% RH non-condensing | | |
| | STORAGE TEMP., HUMIDITY | -40 ~ +85°C, 10 ~ 95% RH | | |
| | TEMP. COEFFICIENT | ±0.03%/°C (0 ~ 50°C) | | |
| | VIBRATION | Component:10 ~ 500Hz, 2G 10min./1cycle, 60min. each along X, Y, Z axes; Mounting: Compliance to IEC60068-2-6 | | |
| SAFETY & EMC (Note 4) | SAFETY STANDARDS | UL508, TUV EN60950-1 approved | | |
| | WITHSTAND VOLTAGE | I/P-O/P:3KVAC I/P-FG:2KVAC O/P-FG:0.5KVAC | | |
| | ISOLATION RESISTANCE | I/P-O/P, I/P-FG, O/P-FG:>100M Ohms / 500VDC / 25°C / 70% RH | | |
| | EMC EMISSION | Compliance to EN55022 (CISPR22) Class A, EN61000-3-2,-3 | | |
| | EMC IMMUNITY | Compliance to EN61000-4-2,3,4,5,6,8,11, EN55024, EN61000-6-2 (EN50082-2), heavy industry level, criteria A | | |
| OTHERS | MTBF | 474.6K hrs min. MIL-HDBK-217F (25°C) | | |
| | DIMENSION | 40*125.2*113.5mm (W*H*D) | | |
| | PACKING | 0.6Kg; 20pcs/13Kg/1.16CUFT | | |
| NOTE | <p>1. All parameters NOT specially mentioned are measured at 230VAC input, rated load and 25°C of ambient temperature.</p> <p>2. Ripple & noise are measured at 20MHz of bandwidth by using a 12" twisted pair-wire terminated with a 0.1uf & 47uf parallel capacitor.</p> <p>3. Tolerance : includes set up tolerance, line regulation and load regulation.</p> <p>4. The power supply is considered a component which will be installed into a final equipment. The final equipment must be re-confirmed that it still meets EMC directives.</p> <p>5. Installation clearances : 40mm on top, 20mm on the bottom, 5mm on the left and right side are recommended when loaded permanently with full power. In case the adjacent device is a heat source, 15mm clearance is recommended.</p> <p>6. Derating may be needed under low input voltage. Please check the derating curve for more details.</p> | | | |

■ Block Diagram

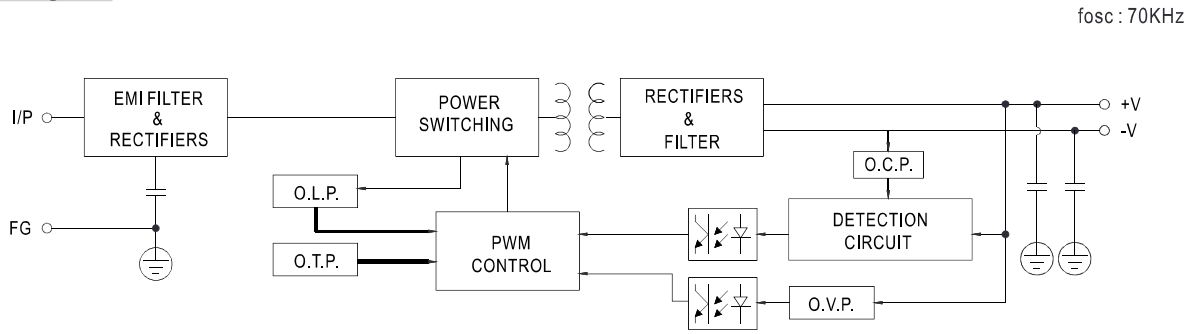

■ Derating Curve

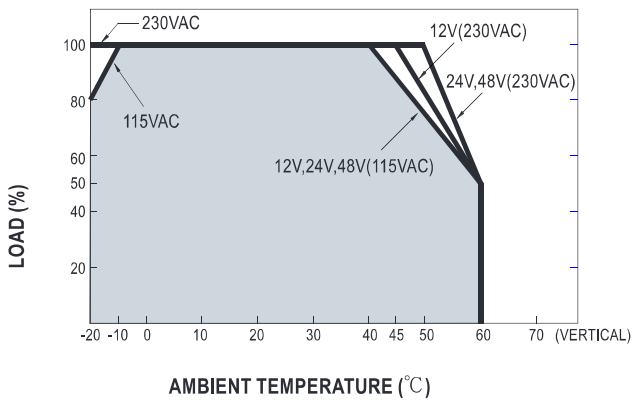

■ Static Characteristics

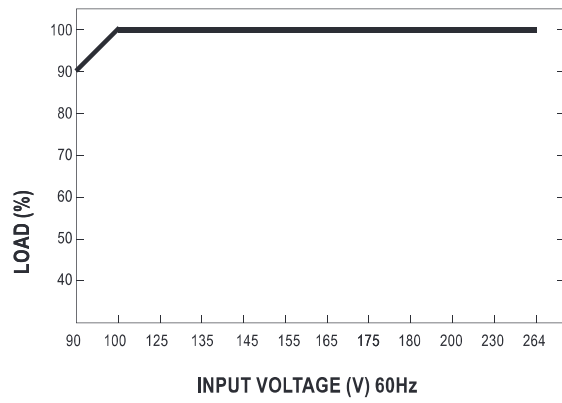

■ Mechanical Specification

Case No.992D Unit:mm

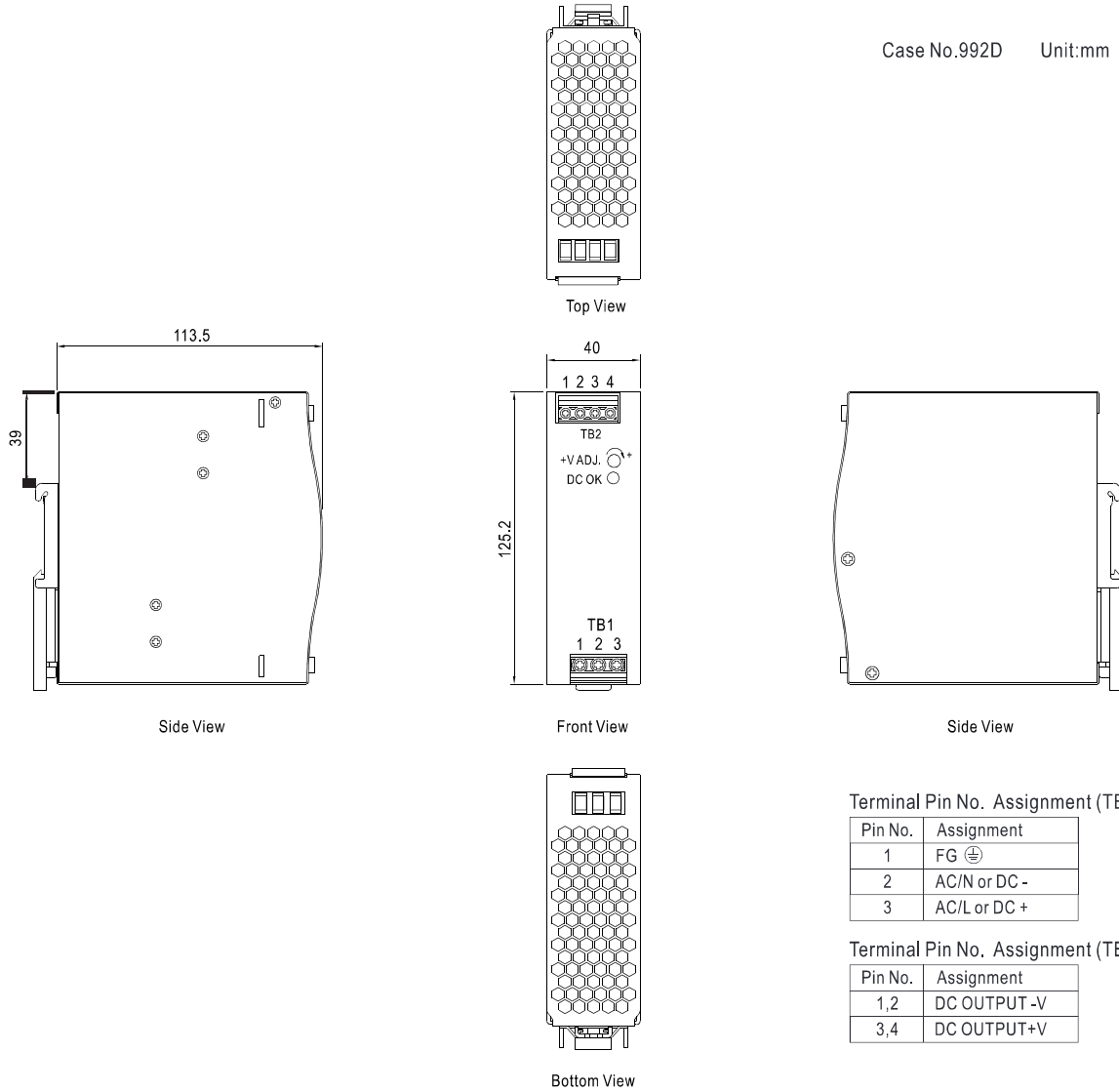

■ Installation Instruction

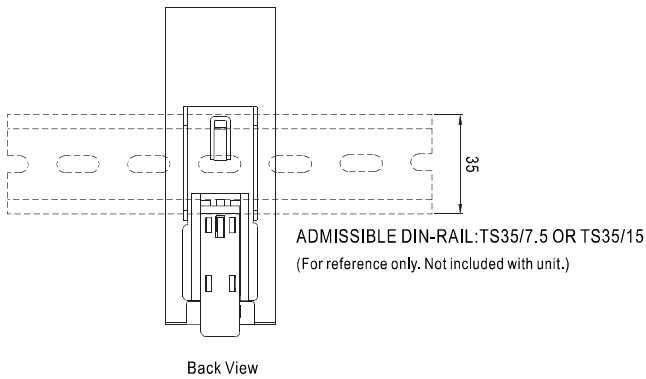

This series fits DIN-RAIL TS35/7.5 or TS35/15.
For installation details, please refer to the USER MANUAL on
http://www.meanwell.com/search/EDR-120/EDR_manual.pdf