

BC556 ... BC559 General Purpose PNP Transistors Universal-PNP-Transistoren	I_C = -100 mA h_{FE} ~ 120/200/400 T_{jmax} = 150°C	V_{CEO} = -30 ... -65 V P_{tot} = 500 mW
---	--	---

Version 2018-02-01

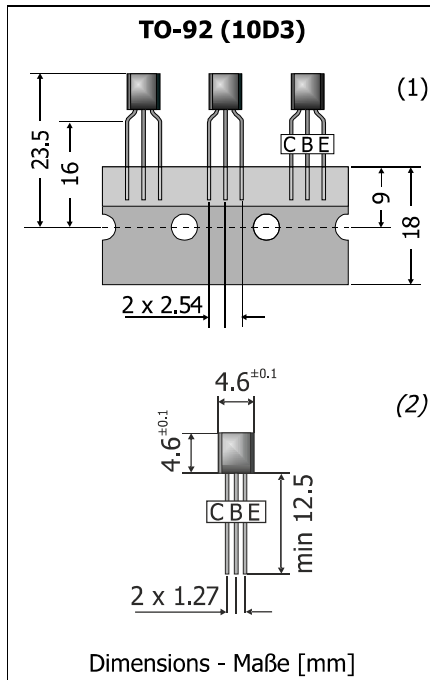

Typical Applications

Signal processing,
Switching, Amplification
Commercial grade ¹⁾

Features

General Purpose
Three current gain groups
Compliant to RoHS, REACH,
Conflict Minerals ¹⁾

Mechanical Data ¹⁾

- (1) Taped in ammo pack (Raster 2.54) 4000
- (2) On request: in bulk (Raster 1.27, suffix "BK") 5000

Weight approx. 0.18 g
Case material UL 94V-0
Solder & assembly conditions 260°C/10s
MSL N/A



Typische Anwendungen

Signalverarbeitung,
Schalten, Verstärken
Standardausführung ¹⁾

Besonderheiten

Universell anwendbar
Drei Stromverstärkungsklassen
Konform zu RoHS, REACH,
Konfliktmineralien ¹⁾

Mechanische Daten ¹⁾

- (1) Gegurtet in Ammo-Pack (Raster 2.54)
- (2) Auf Anfrage: Schüttgut (Raster 1.27, Suffix "BK")

Gewicht ca. 0.18 g
Gehäusematerial UL 94V-0
Löt- und Einbaubedingungen

Current gain groups Stromverstärkungsgruppen			Recommended complementary NPN transistors Empfohlene komplementäre NPN-Transistoren
BC556A	BC556B	BC556C	BC546 ... BC549
BC557A	BC557B	BC557C	
BC558A	BC558B	BC558C	
BC559A	BC559B	BC559C	

Maximum ratings ²⁾

Grenzwerte ²⁾

			BC556	BC557	BC558/559
Collector-Emitter-voltage – Kollektor-Emitter-Spannung	E-B short	- V _{CES}	80 V	50 V	30 V
Collector-Emitter-voltage – Kollektor-Emitter-Spannung	B open	- V _{CEO}	65 V	45 V	30 V
Emitter-Base-voltage – Emitter-Basis-Spannung	E open	- V _{CBO}	80 V	50 V	30 V
Emitter-Base-voltage – Emitter-Basis-Spannung	C open	- V _{EBO}	5 V		
Power dissipation – Verlustleistung		P _{tot}	500 mW ³⁾		
Collector current – Kollektorstrom	DC	- I _C	100 mA		
Peak Collector current – Kollektor-Spitzenstrom		- I _{CM}	200 mA		
Peak Base current – Basis-Spitzenstrom		- I _{BM}	200 mA		
Peak Emitter current – Emitter-Spitzenstrom		I _{EM}	200 mA		
Junction temperature – Sperrschichttemperatur		T _j	-55...+150°C		
Storage temperature – Lagerungstemperatur		T _s	-55...+150°C		

1 Please note the [detailed information on our website](#) or at the beginning of the data book
Bitte beachten Sie die [detaillierten Hinweise auf unserer Internetseite](#) bzw. am Anfang des Datenbuches

2 T_A = 25°C, unless otherwise specified – T_A = 25°C, wenn nicht anders angegeben

3 Valid, if leads are kept at ambient temperature at a distance of 2 mm from case
Gültig wenn die Anschlussdrähte in 2 mm Abstand vom Gehäuse auf Umgebungstemperatur gehalten werden

Characteristics
Kennwerte

				$T_j = 25^\circ\text{C}$	Min.	Typ.	Max.
DC current gain – Kollektor-Basis-Stromverhältnis ¹⁾							
- $V_{CE} = 5\text{ V}$	- $I_C = 10\ \mu\text{A}$	Group A	h_{FE}	–	90	–	
		Group B		–	150	–	
		Group C		–	270	–	
	- $I_C = 2\text{ mA}$	Group A	h_{FE}	110	–	220	
		Group B		200	–	450	
		Group C		420	–	800	
	- $I_C = 100\text{ mA}$	Group A	h_{FE}	–	120	–	
		Group B		–	200	–	
		Group C		–	400	–	
Collector-Emitter cutoff current – Kollektor-Emitter-Reststrom							
- $V_{CE} = 80\text{ V}$ 50 V 30 V	B-E short	BC556	- I_{CES}	–	0.2 nA	15 nA	
		BC557					
		BC558 / BC559					
- $V_{CE} = 80\text{ V}$ 50 V 30 V	B-E short $T_j = 125^\circ\text{C}$	BC556 BC557 BC558 / BC559	- I_{CES}	–	–	4 μA	
Collector-Emitter saturation voltage – Kollektor-Emitter-Sättigungsspg. ¹⁾							
- $I_C = 10\text{ mA}$	- $I_B = 0.5\text{ mA}$		- V_{CEsat}	–	80 mV	300 mV	
- $I_C = 100\text{ mA}$	- $I_B = 5\text{ mA}$			–	250 mV	650 mV	
Base-Emitter saturation voltage – Basis-Emitter-Sättigungsspannung ¹⁾							
- $I_C = 10\text{ mA}$	- $I_B = 0.5\text{ mA}$		- V_{BEsat}	–	700 mV	–	
- $I_C = 100\text{ mA}$	- $I_B = 5\text{ mA}$			–	900 mV	–	
Base-Emitter-voltage – Basis-Emitter-Spannung ¹⁾							
- $V_{CE} = 5\text{ V}$	- $I_C = 2\text{ mA}$		- V_{BE}	600 mV	660 mV	750 mV	
	- $I_C = 10\text{ mA}$			–	–	820 mV	
Gain-Bandwidth Product – Transitfrequenz							
- $V_{CE} = 5\text{ V}$, - $I_C = 10\text{ mA}$, $f = 100\text{ MHz}$			f_T	–	150 MHz	–	
Collector-Base Capacitance – Kollektor-Basis-Kapazität							
- $V_{CB} = 10\text{ V}$, $I_E = I_C = 0$, $f = 1\text{ MHz}$			C_{CBO}	–	3.5 pF	6 pF	
Emitter-Base Capacitance – Emitter-Basis-Kapazität							
- $V_{EB} = 0.5\text{ V}$, $I_C = I_E = 0$, $f = 1\text{ MHz}$			C_{EBO}	–	10 pF	–	
Noise figure – Rauschzahl							
- $V_{CE} = 5\text{ V}$, - $I_C = 200\ \mu\text{A}$, $R_G = 2\text{ k}\Omega$ $f = 1\text{ kHz}$, $\Delta f = 200\text{ Hz}$	BC556 ... BC558 BC559		F	–	2 dB 1 dB	10 dB 4 dB	
Thermal resistance junction to ambient Wärmewiderstand Sperrschicht – Umgebung			R_{thA}	< 200 K/W ²⁾			

Disclaimer: See data book page 2 or [website](#)
Haftungsausschluss: Siehe Datenbuch Seite 2 oder [Internet](#)

1 Tested with pulses $t_p = 300\ \mu\text{s}$, duty cycle $\leq 2\%$ – Gemessen mit Impulsen $t_p = 300\ \mu\text{s}$, Schaltverhältnis $\leq 2\%$
 2 Valid, if leads are kept at ambient temperature at a distance of 2 mm from case
 Gültig wenn die Anschlussdrähte in 2 mm Abstand vom Gehäuse auf Umgebungstemperatur gehalten werden