

BC546 ... BC549 General Purpose NPN Transistors Universal-NPN-Transistoren	I_C = 100 mA h_{FE} ~ 110/200/420 T_{jmax} = 150°C	V_{CE0} = 30...65 V P_{tot} = 500 mW
---	---	---

Version 2018-02-01

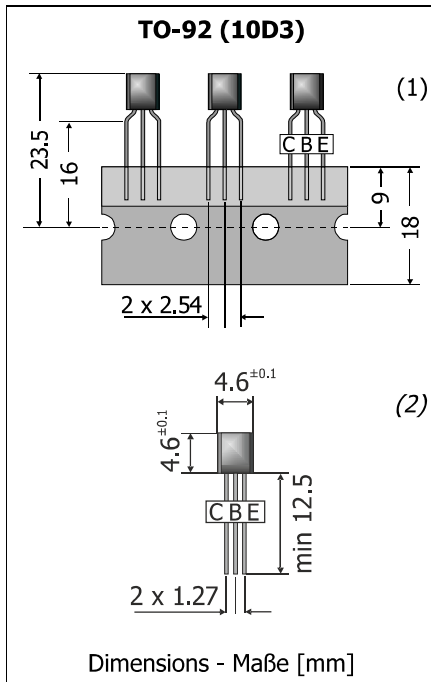

Typical Applications

Signal processing,
Switching, Amplification
Commercial grade ¹⁾

Features

General Purpose
Three current gain groups
Compliant to RoHS, REACH,
Conflict Minerals ¹⁾

Mechanical Data ¹⁾

- (1) Taped in ammo pack (Raster 2.54) 4000
- (2) On request: in bulk (Raster 1.27, suffix "BK") 5000

Weight approx. 0.01 g
Case material UL 94V-0
Solder & assembly conditions 260°C/10s
MSL N/A



Typische Anwendungen

Signalverarbeitung,
Schalten, Verstärken
Standardausführung ¹⁾

Besonderheiten

Universell anwendbar
Drei Stromverstärkungsklassen
Konform zu RoHS, REACH,
Konfliktmineralien ¹⁾

Mechanische Daten ¹⁾

- (1) Gegurtet in Ammo-Pack (Raster 2.54)
- (2) Auf Anfrage: Schüttgut (Raster 1.27, Suffix "BK")

Gewicht ca. 0.01 g
Gehäusematerial UL 94V-0
Löt- und Einbaubedingungen

Current gain groups Stromverstärkungsgruppen			Recommended complementary PNP transistors Empfohlene komplementäre PNP-Transistoren
BC546A	BC546B	BC546C	BC556 ... BC559
BC547A	BC547B	BC547C	
BC548A	BC548B	BC548C	
BC549A	BC549B	BC549C	

Maximum ratings ²⁾

Grenzwerte ²⁾

			BC546	BC547	BC548/549
Collector-Emitter-voltage – Kollektor-Emitter-Spannung	E-B short	V _{CEs}	80 V	50 V	30 V
Collector-Emitter-voltage – Kollektor-Emitter-Spannung	B open	V _{CE0}	65 V	45 V	30 V
Emitter-Base-voltage – Emitter-Basis-Spannung	C open	V _{EBO}	80 V	50 V	30 V
Emitter-Base-voltage	C open	V _{EBO}	5 V		
Power dissipation – Verlustleistung		P _{tot}	500 mW ³⁾		
Collector current – Kollektorstrom	DC	I _C	100 mA		
Peak Collector current – Kollektor-Spitzenstrom		I _{CM}	200 mA		
Peak Base current – Basis-Spitzenstrom		I _{BM}	200 mA		
Peak Emitter current – Emitter-Spitzenstrom		- I _{EM}	200 mA		
Junction temperature – Sperrschichttemperatur		T _j	-55...+150°C		
Storage temperature – Lagerungstemperatur		T _s	-55...+150°C		

1 Please note the [detailed information on our website](#) or at the beginning of the data book
Bitte beachten Sie die [detaillierten Hinweise auf unserer Internetseite](#) bzw. am Anfang des Datenbuches
2 T_A = 25°C, unless otherwise specified – T_A = 25°C, wenn nicht anders angegeben
3 Valid, if leads are kept at ambient temperature at a distance of 2 mm from case
Gültig wenn die Anschlussdrähte in 2 mm Abstand vom Gehäuse auf Umgebungstemperatur gehalten werden

Characteristics

Kennwerte

				T _j = 25°C											
				Min.	Typ.	Max.									
DC current gain – Kollektor-Basis-Stromverhältnis ¹⁾															
V _{CE} = 5 V	I _C = 10 μA	Group A	h _{FE}	–	90	–									
		Group B		–	150	–									
		Group C		–	270	–									
	I _C = 2 mA	Group A	h _{FE}	110	–	220									
		Group B		200	–	450									
		Group C		420	–	800									
	I _C = 100 mA	Group A	h _{FE}	–	120	–									
		Group B		–	200	–									
		Group C		–	400	–									
Collector-Emitter cutoff current – Kollektor-Emitter-Reststrom															
V _{CE} =	80 V 50 V 30 V	B-E short	BC546 BC547 BC548 / BC549	I _{CES}	–	0.2 nA	15 nA								
								V _{CE} =	80 V 50 V 30 V	B-E short T _j = 125°C	BC546 BC547 BC548 / BC549	I _{CES}	–	–	4 μA
Collector-Emitter saturation voltage – Kollektor-Emitter-Sättigungsspg. ¹⁾															
I _C = 10 mA	I _B = 0.5 mA	V _{CEsat}	–	80 mV	250 mV										
			I _C = 100 mA	I _B = 5 mA	–	200 mV	600 mV								
Base-Emitter saturation voltage – Basis-Emitter-Sättigungsspannung ¹⁾															
I _C = 10 mA	I _B = 0.5 mA	V _{BEsat}	–	700 mV	–										
			I _C = 100 mA	I _B = 5 mA	–	900 mV	–								
Base-Emitter-voltage – Basis-Emitter-Spannung ¹⁾															
V _{CE} = 5 V	I _C = 2 mA	V _{BE}	580 mV	660 mV	700 mV										
			V _{CE} = 5 V	I _C = 10 mA	–	–	770 mV								
Gain-Bandwidth Product – Transitfrequenz															
V _{CE} = 5 V, I _C = 10 mA, f = 100 MHz				f _T	–	300 MHz	–								
Collector-Base Capacitance – Kollektor-Basis-Kapazität															
V _{CB} = 10 V, I _E = i _e = 0, f = 1 MHz				C _{CB0}	–	3.5 pF	6 pF								
Emitter-Base Capacitance – Emitter-Basis-Kapazität															
V _{EB} = 0.5 V, I _C = i _c = 0, f = 1 MHz				C _{EB0}	–	9 pF	–								
Noise figure – Rauschzahl															
V _{CE} = 5 V, I _C = 200 μA, R _G = 2 kΩ	f = 1 kHz, Δf = 200 Hz	F	–	2 dB	10 dB										
			–	1.2 dB	4 dB										
Thermal resistance junction to ambient Wärmewiderstand Sperrschicht – Umgebung				R _{thA}	< 200 K/W ²⁾										

Disclaimer: See data book page 2 or [website](#)

Haftungsausschluss: Siehe Datenbuch Seite 2 oder [Internet](#)

1 Tested with pulses t_p = 300 μs, duty cycle ≤ 2% – Gemessen mit Impulsen t_p = 300 μs, Schaltverhältnis ≤ 2%

2 Valid, if leads are kept at ambient temperature at a distance of 2 mm from case
Gültig wenn die Anschlussdrähte in 2 mm Abstand vom Gehäuse auf Umgebungstemperatur gehalten werden