

# TOGGLE SWITCH

## Features

- Power Switch conforms to safety standards for electrical equipment.
- Compact with a good space factor.



## Specifications

Item	Standard
Rating	10A 1250VAC / 15A 250VAC , UL1054
Conduit Resistance	25mΩ max. (Initial)
Dielectric Resistance	AC 1000V (50/60 Hz for 1 minute)
Insulation Resistance	100MΩ min (at 500 VDC)
Electrically Life	30,000 Cycle min
Mechanically Life	100,000 Cycle min

## Product Selection

T-     
1 2 3

### 1. CONTACT TYPES

11: 2P ON-OFF	SPST
12: 3P ON-ON	SPDT
13: 3P ON-OFF-ON	SPDT
21: 4P ON-OFF	DPST
22: 6P ON-ON	DPST
23: 6P ON-OFF-ON	DPDT

### 2. TERMINAL TYPES

A: SOLDER
B: SCREW
C: #250 QUICK CONNECT

### 3. RARING TYPES

_ : 10A 250VAC
S : 15A 250VAC

## Treminal Dimension

A: SOLDER TYPE

B: SCREW TYPE

C: #250 QUICK CONNECT TYPE

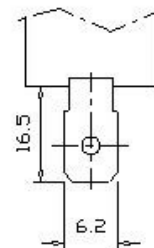
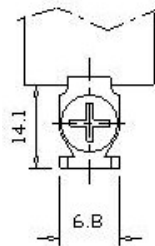
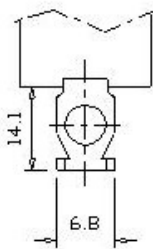

HIGHLY













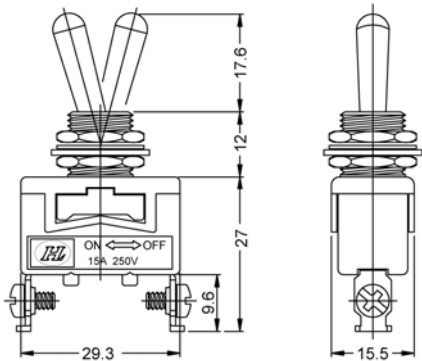

E1

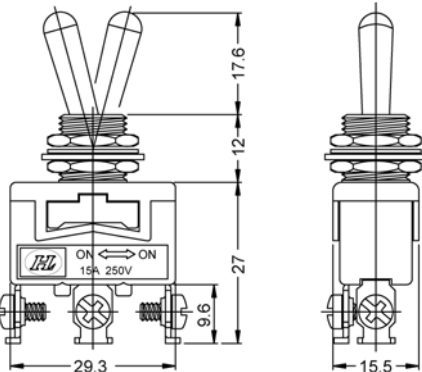
Design, specifications are subject to change without notice.

# TOGGLE SWITCH

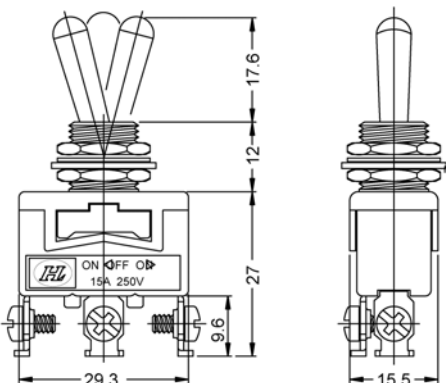
## Dimensions

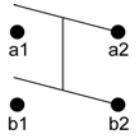
Unit: mm

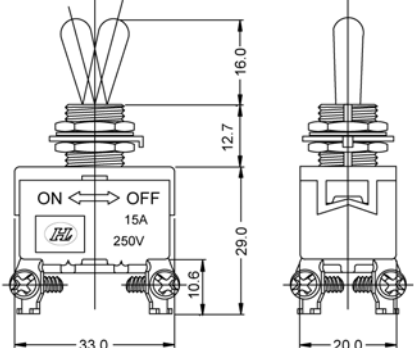
Item No.	Function	Dimensions
T-11	   <b>2P SPST</b>	
T-12	   <b>3P SPDT</b>	
T-13	   <b>3P SPDT</b>	
T-21	   <b>4P DPST</b>	

HIGHLY

E2

Design, specifications are subject to change without notice.

# TOGGLE SWITCH

## OPERATING CHARACTERISTICS

Unit: mm

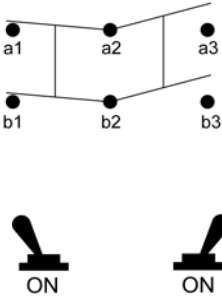
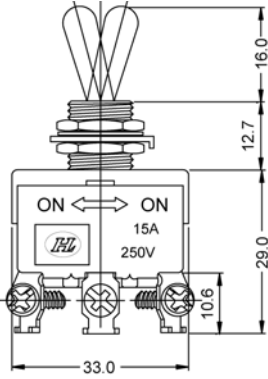
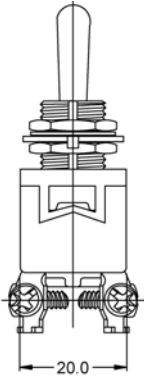
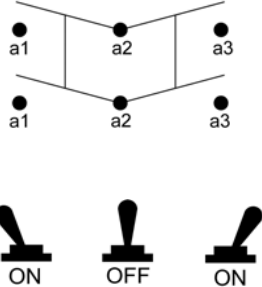
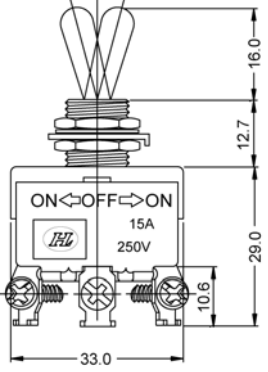
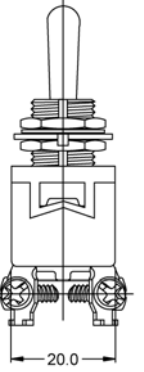
Item No.	Function	Dimensions	
T-22	 <p data-bbox="675 663 788 689"><b>6P DPST</b></p>		
T-23	 <p data-bbox="675 1084 788 1111"><b>6P DPDT</b></p>		
TR-1	