



ECO 01

Ultra slim design with 35mm

ECO 02

ECO 03

ECO 04

Class LPS (Limited power source)

ECO 05

ECO 06

Cooling by free air convection (working temperature: -30~+70°C)

DIN rail TS-35/7.5 or 15 mountable

LED indicator for power on

ECO 07

ECO 08

ECO 09	ECO 10	ECO 11	ECO 12	ECO 13	ECO 14	ECO 15	ECO 16	ECO 17	ECO 18	ECO 19	ECO 20	ECO 21	ECO 22	ECO 23	ECO 24	ECO 25	ECO 26	ECO 27	ECO 28	ECO 29	ECO 30	ECO 31	ECO 32	ECO 33	ECO 34	ECO 35	ECO 36	ECO 37	ECO 38	ECO 39	ECO 40	ECO 41	ECO 42	ECO 43	ECO 44	ECO 45	ECO 46	ECO 47	ECO 48	ECO 49	ECO 50	ECO 51	ECO 52	ECO 53	ECO 54	ECO 55	ECO 56	ECO 57	ECO 58	ECO 59	ECO 60	ECO 61	ECO 62	ECO 63	ECO 64	ECO 65	ECO 66	ECO 67	ECO 68	ECO 69	ECO 70	ECO 71	ECO 72	ECO 73	ECO 74	ECO 75	ECO 76	ECO 77	ECO 78	ECO 79	ECO 80	ECO 81	ECO 82	ECO 83	ECO 84	ECO 85	ECO 86	ECO 87	ECO 88	ECO 89	ECO 90	ECO 91	ECO 92	ECO 93	ECO 94	ECO 95	ECO 96	ECO 97	ECO 98	ECO 99	ECO 100
--------	--------	--------	--------	--------	--------	--------	--------	--------	--------	--------	--------	--------	--------	--------	--------	--------	--------	--------	--------	--------	--------	--------	--------	--------	--------	--------	--------	--------	--------	--------	--------	--------	--------	--------	--------	--------	--------	--------	--------	--------	--------	--------	--------	--------	--------	--------	--------	--------	--------	--------	--------	--------	--------	--------	--------	--------	--------	--------	--------	--------	--------	--------	--------	--------	--------	--------	--------	--------	--------	--------	--------	--------	--------	--------	--------	--------	--------	--------	--------	--------	--------	--------	--------	--------	--------	--------	--------	--------	--------	--------	---------

ECO 101

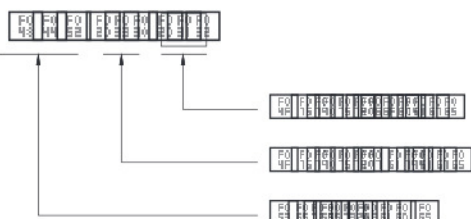

SPECIFICATION

MODEL		HDR-30-5	HDR-30-12	HDR-30-15	HDR-30-24	HDR-30-48	
OUTPUT	DC VOLTAGE	5V	12V	15V	24V	48V	
	RATED CURRENT	3A	2A	2A	1.5A	0.75A	
	CURRENT RANGE	0~3A	0~2A	0~2A	0~1.5A	0~0.75A	
	RATED POWER	15W	24W	30W	36W	36W	
	RIPPLE & NOISE (max.) Note.2	80mVp-p	120mVp-p	120mVp-p	150mVp-p	240mVp-p	
	VOLTAGE ADJ. RANGE	4.5~5.5V	10.8~13.8V	13.5~18V	21.6~29V	43.2~55.2V	
	VOLTAGE TOLERANCE Note.3	± 2.0%	± 1.0%	± 1.0%	± 1.0%	± 1.0%	
	LINE REGULATION	± 1.0%	± 1.0%	± 1.0%	± 1.0%	± 1.0%	
	LOAD REGULATION	± 1.0%	± 1.0%	± 1.0%	± 1.0%	± 1.0%	
	SETUP, RISE TIME	500ms, 50ms/230VAC    500ms, 50ms/115VAC at full load					
	HOLD UP TIME (Typ.)	30ms/230VAC    12ms/115VAC at full load					
INPUT	VOLTAGE RANGE	85~264VAC (277VAC available)		120~370VDC (390VDC available)			
	FREQUENCY RANGE	47~63Hz					
	EFFICIENCY (Typ.)	82%	88%	89%	89%	90%	
	AC CURRENT (Typ.)	0.88A/115VAC    0.48A/230VAC					
	INRUSH CURRENT (Typ.)	COLD START 25A/115VAC    45A/230VAC					
PROTECTION	OVERLOAD Note.4	105~160% rated output power Protection type: Constant current limiting, recovers automatically after fault condition is removed					
	OVER VOLTAGE	5.75~7.5V	15~18V	18.8~22.5V	30~36V	57.6~67.2V	
ENVIRONMENT	WORKING TEMP	-30~+70°C (Refer to "Derating Curve")					
	WORKING HUMIDITY	20~90% RH non-condensing					
	STORAGE TEMP., HUMIDITY	-40~+85°C, 10~95% RH non-condensing					
	TEMP. COEFFICIENT	± 0.03%/°C (0~50°C) RH non-condensing					
	VIBRATION	10~500Hz, 2G 10min./1cycle, period for 60min. each along X, Y, Z axes; Mounting: Compliance to IEC60068-2-6					
	OPERATING ALTITUDE	2000 meters					
SAFETY & EMC (Note 5)	SAFETY STANDARDS	UL60950-1, UL508, TUV/EN61558-2-16, IEC60950-1 approved; Design refer to EN50178, TUV EN60950-1					
	WITHSTAND VOLTAGE	I/P-O/P:3KVAC					
	ISOLATION RESISTANCE	I/P-O/P:100M Ohms / 500VDC / 25°C / 70% RH					
	EMC EMISSION	Parameter	Standard		Test Level / Note		
		Conducted	EN55032(CISPR32)		Class B		
		Radiated	EN55032(CISPR32)		Class B		
		Harmonic Current	EN61000-3-2		Class A		
		Voltage Flicker	EN61000-3-3		-----		
	EMC IMMUNITY	EN55024, EN55035, EN61000-6-2, EN61204-3					
		Parameter	Standard		Test Level / Note		
ESD		EN61000-4-2		Level 3, 8KV air; Level 2, 4KV contact, criteria A			
Radiated Susceptibility		EN61000-4-3		Level 3, criteria A			
EFT/Burst		EN61000-4-4		Level 3, criteria A			
Surge		EN61000-4-5		Level 4, 2KV/L-N, criteria A			
Conducted		EN61000-4-6		Level 3, criteria A			
Magnetic Field		EN61000-4-8		Level 4, criteria A			
Voltage Dips and interruptions	EN61000-4-11		>95% dip 0.5 periods, 30% dip 25 periods, >95% interruptions 250 periods				
OTHERS	MTBF	968.1Khrs min.    MIL-HDBK-217F (25°C)					
	DIMENSION	35*90*54.5mm (W*H*D)					
	PACKING	0.12Kg/96pcs/12.5Kg/1.04CUFT					
NOTE	<p>1. The output voltage is adjustable by potentiometer. The potentiometer is located on the top of the power supply. The potentiometer is factory set to 5V. The output voltage can be adjusted from 4.5V to 5.5V. The potentiometer is not adjustable for 12V, 15V, 24V and 48V models.</p> <p>2. The ripple and noise is measured at the output terminal with a load regulation of 10% and a load current of 10% of the rated current. The ripple and noise is measured with a load regulation of 10% and a load current of 10% of the rated current. The ripple and noise is measured with a load regulation of 10% and a load current of 10% of the rated current.</p> <p>3. The voltage tolerance is measured at the output terminal with a load regulation of 10% and a load current of 10% of the rated current. The voltage tolerance is measured at the output terminal with a load regulation of 10% and a load current of 10% of the rated current. The voltage tolerance is measured at the output terminal with a load regulation of 10% and a load current of 10% of the rated current.</p> <p>4. The protection type is constant current limiting. The protection type is constant current limiting. The protection type is constant current limiting. The protection type is constant current limiting. The protection type is constant current limiting.</p> <p>5. The safety standards are UL60950-1, UL508, TUV/EN61558-2-16, IEC60950-1 approved. The safety standards are UL60950-1, UL508, TUV/EN61558-2-16, IEC60950-1 approved. The safety standards are UL60950-1, UL508, TUV/EN61558-2-16, IEC60950-1 approved.</p>						

■ Block Diagram

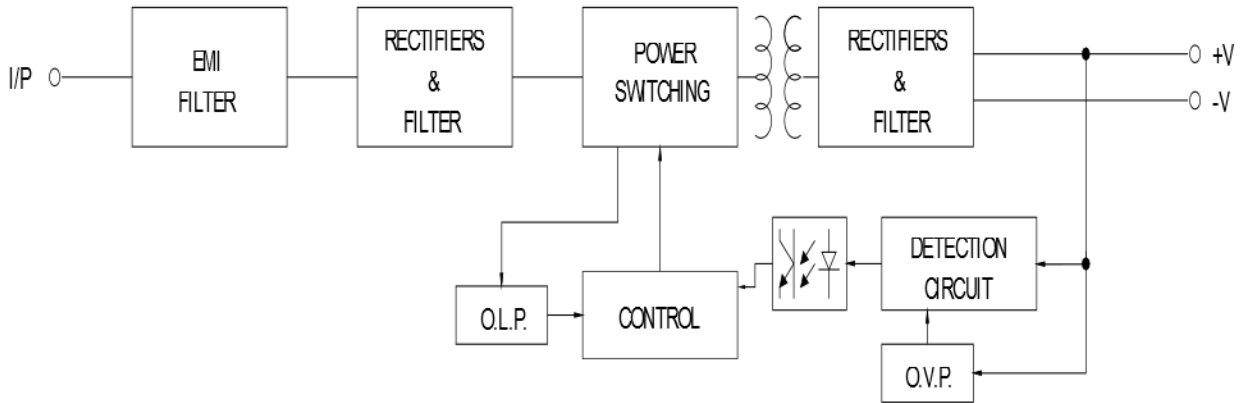

■ Derating Curve

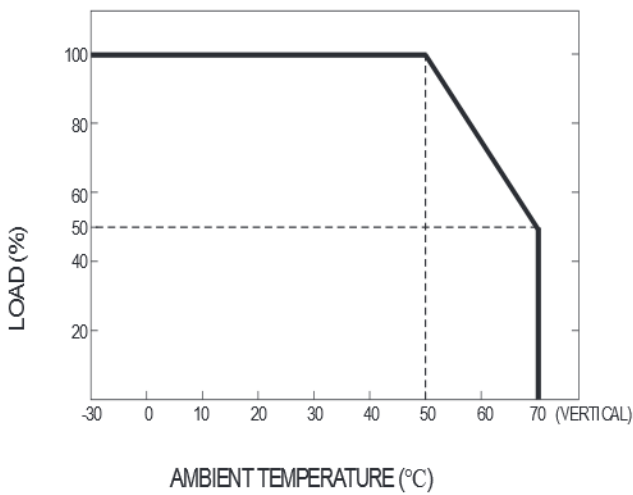

■ Output Derating VS Input Voltage

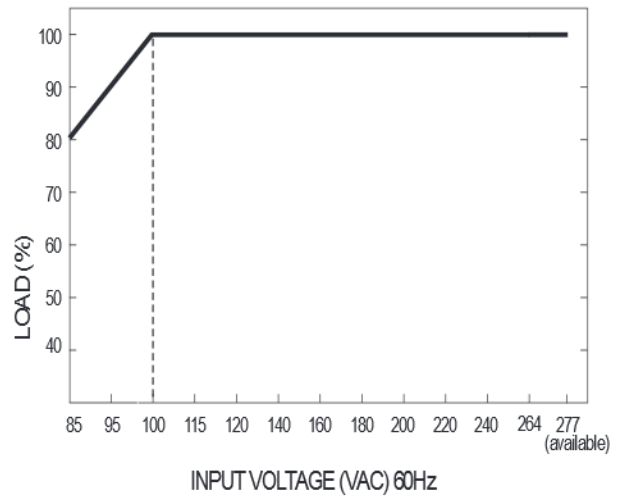

■ Mechanical Specification

( Unit: mm , tolerance  $\pm 0.5\text{mm}$  )

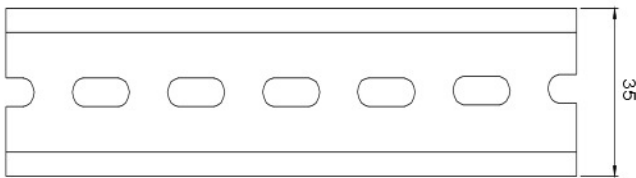
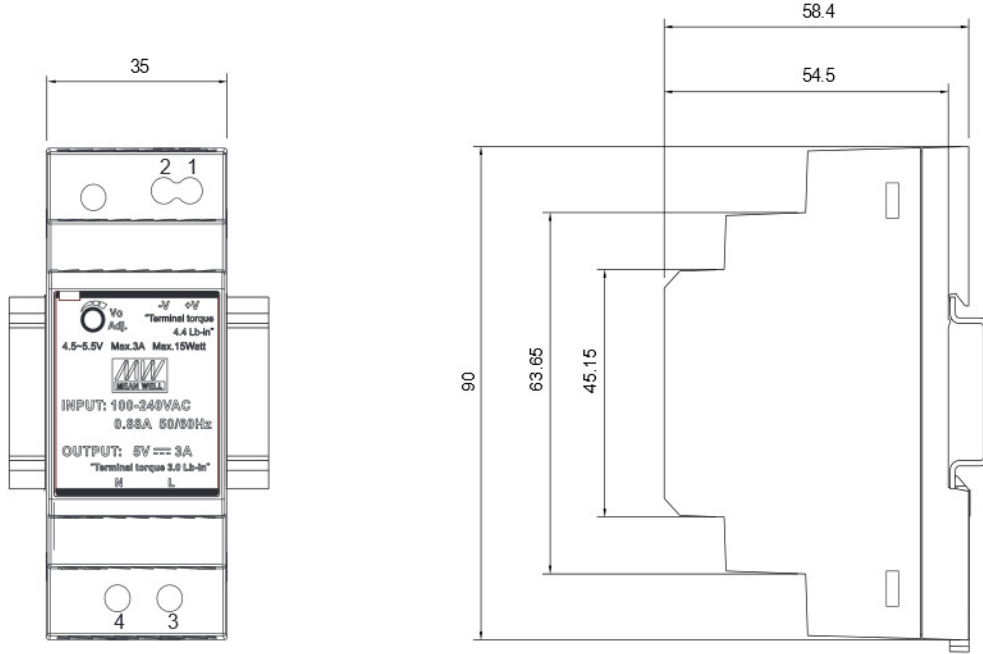

ADMISSIBLE DIN-RAIL: TS35/7.5 OR TS35/15

Terminal Pin No. Assignment

Pin No.	Assignment	Pin No.	Assignment
1	+V	3	AC/L
2	-V	4	AC/N

■ Installation Manual

Please refer to : <http://www.meanwell.com/manual.html>