

BOM LIST			
ITEM	PART NAME	Q'ty	NOTES
1	PLASTIC HOOD	2	ABS
2	2.1 LONG BOLT	2	#4-40
	2.2 SHORT BOLT	2	#4-40
3	NUT	2	M3
4	LONG SCREW	2	M3
5	SMALL WASHER	2	
6	SHORT SCREW	2	M3
7	7.1 METAL WASHER	2	M3
	7.2 PLASTIC-1 WASHER	2	ABS
	7.3 PLASTIC-2 WASHER	2	ABS

REV.	DESCRIPTION	DRAWN	CHECKED	APPROVED
A	NEW RELEASE	LJH 05/18/05'	~	LJC 05/18/05'
B	整理图画	YCH 09/13/07'	~	LJC 09/13/07'
C	整理英制短螺丝尺寸	YCH 07/18/08'	~	

NOTES:
 1. Hardwares are all Nickel plated.
 2. PART NUMBER CODE:

DS1045 - 15 X X X X X
 Washer type
 1: Metal
 2: Plastic-1(Lock type)
 3: Plastic-2(Screw type)
 Bolt type
 L: Long
 S: Short
 Packing type
 1: Mix packing
 2: Separation packing
 Cover Material
 P: Plastic(ABS)
 Cover Color
 A: Gray
 B: Black
 V: Ivory
 Position
 15: 15pin

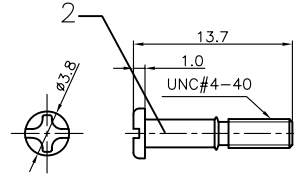
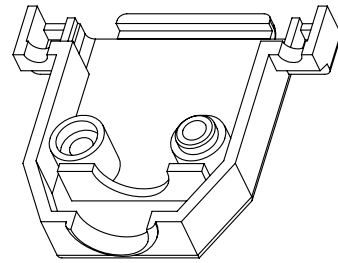

Short BOLT

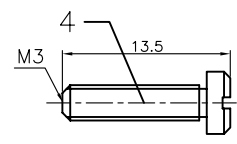

LONG SCREW

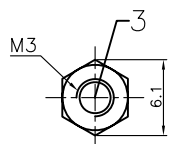

NUT t=2.3mm

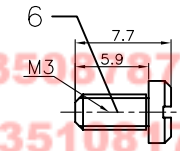

SHORT SCREW

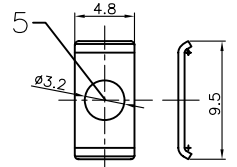

SMALL WASHER

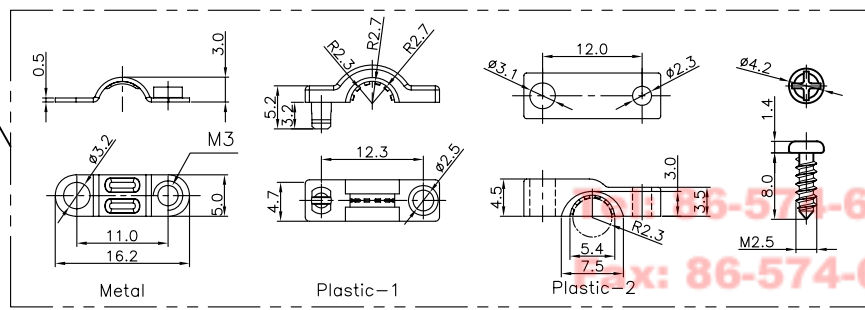
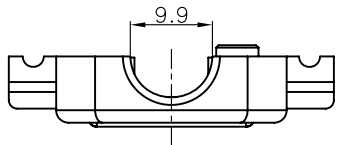
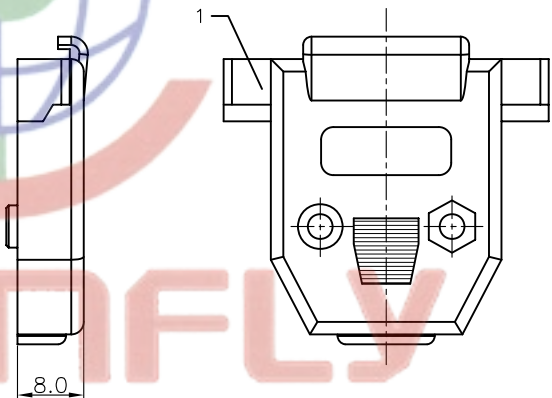
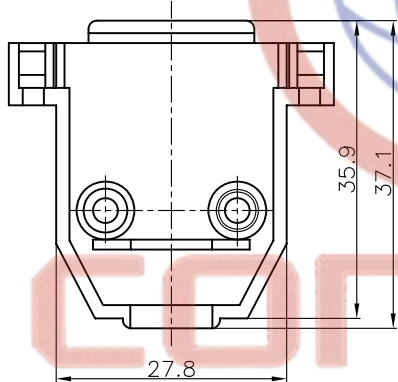

Long BOLT

GENERAL TOLERANCE	ANGLE TOLERANCE
X. ±0.60	X. ±5°
.X ±0.38	.X ±3°
.XX ±0.25	.XX ±2°

PROJECTION	TITLE
UNITS mm	D-SUB 15pin Hood
SHEET SIZE A4	SERIES DS1045 SERIES

DRAWING TYPE	COSTOMER
SCALE 1:1	SHEET 1 OF 1
DRAWING NO. C-DS1045-15XXXXX-C	

晨翔电子有限公司
CONNFLY CONNFLY ELECTRONIC CO. LTD

BOM LIST			
ITEM	PART NAME	Q'ty	NOTES
1	PLASTIC HOOD	2	ABS
2	LONG BOLT	2	#4-40
	SHORT BOLT	2	#4-40
3	NUT	2	M3
4	LONG SCREW	2	M3
5	SMALL WASHER	2	
6	SHORT SCREW	2	M3
7.1	METAL WASHER	2	M3
7.2	PLASTIC-1 WASHER	2	ABS
7.3	PLASTIC-2 WASHER	2	ABS

REV.	DESCRIPTION	DRAWN	CHECKED	APPROVED
A	NEW RELEASE	LJH 10/26/05'	~	LJC 10/26/05'
B	整理图画	YCH 09/13/07'	~	LJC 09/13/07'
C	整理英制短螺丝尺寸	YCH 07/18/08'	~	

NOTES:

1. Hardware are all Nickel plated.
2. PART NUMBER CODE:

DS1045 - 37 X X X X X

- Washer type
 - 1: Metal
 - 2: Plastic-1 (Lock type)
 - 3: Plastic-2 (Screw type)
- Bolt type
 - L: Long
 - S: Short
- Packing type
 - 1: Mix packing
 - 2: Separation packing
- Cover Material
 - P: Plastic (ABS)
- Cover Color
 - A: Gray
 - B: Black
 - V: Ivory
- Position
 - 37: 37pin

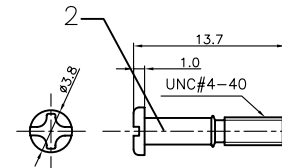
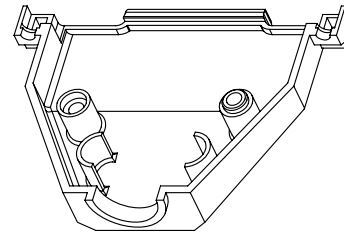

Short BOLT

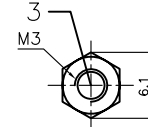

NUT t=2.3mm

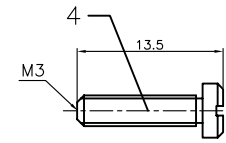

LONG SCREW

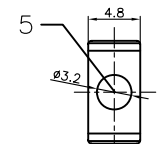

SMALL WASHER

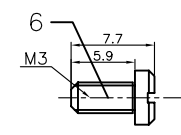

SHORT SCREW

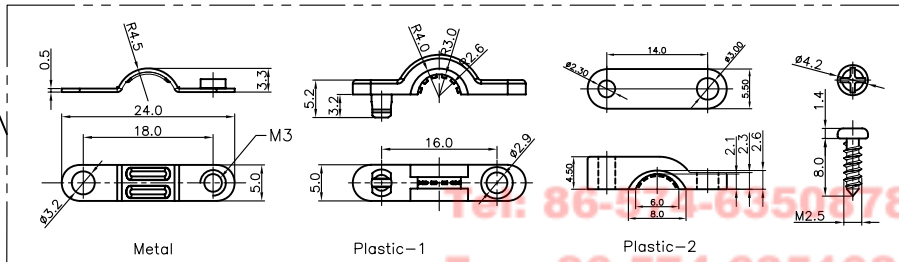

Metal

Plastic-1

Plastic-2

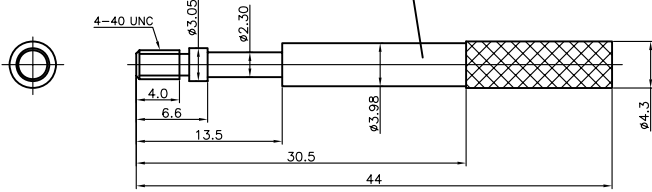
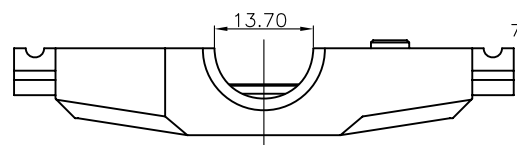
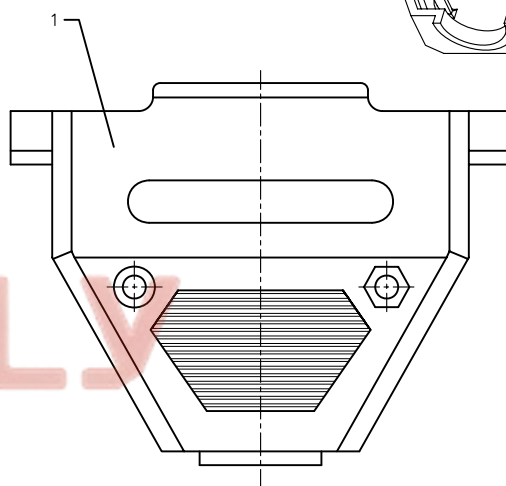
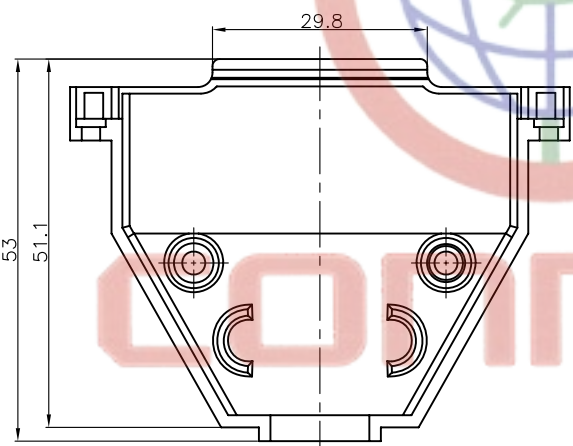
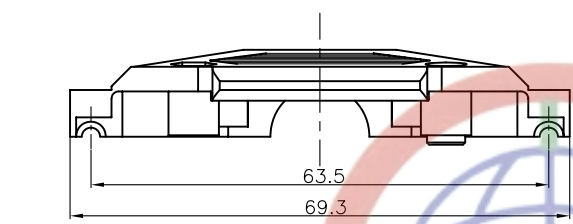

Long BOLT

GENERAL TOLERANCE

- X. ±0.60
- .X ±0.38
- .XX ±0.25

ANGLE TOLERANCE

- X. ±5°
- .X ±3°
- .XX ±2°

PROJECTION

UNITS

SHEET SIZE



mm

A4

TITLE

D-SUB 37pin Hood

SERIES

DS1045 SERIES

DRAWING TYPE

SCALE

DRAWING NO.

COSTOMER

1:1

C-DS1045-37XXXXX-C

SHEET 1 OF 1



晨翔电子有限公司
CONNFLY CONNFLY ELECTRONIC CO. LTD

Tel: 86-574-63510817
Fax: 86-574-63510817