

CL 10 C 101 J B 8 N N N C
1 2 3 4 5 6 7 8 9 10 11

1. SERIES CODE

CL=Multi layer Ceramic Capacitors

2. SIZE CODE

inch(mm)
 02=01005(0402) 21=0805(2012) 43=1812(4532)
 03=0201(0603) 31=1206(3216) 55=2220(5750)
 05=0402(1005) 32=1210(3225)
 10=0603(1608) 42=1808(4520)

* 3. DIELECTRIC CODE

| Class I | Class II |
|---------|-------------------------------------|
| C=COG | A=X5R F=Y5V B=X7R X=X6S Y=X7S |

** 4. CAPACITANCE CODE

Capacitance expressed in pF. 2 significant digits plus number of zeros.
 example) 106=10 × 10⁶=1000000pF
 For Values < 10pF, Letter R denotes decimal point
 example) 1R5=1.5pF

5. TOLERANCE CODE

A=±0.05pF D=±0.5pF J=±5% Z=+80/-20%
 B=±0.1pF F=±1pF, ±1%* K=±10%
 C=±0.25pF G=±2% M=±20%
 *For Values ≤ 10pF, F=±1pF
 Values > 10pF, F=±1%

6. RATED VOLTAGE CODE

R=4V O=16V B=50V E=250V H=630V K=3000V
 Q=6.3V A=25V C=100V F=350V I=1000V
 P=10V L=35V D=200V G=500V J=2000V

*** 7. THICKNESS CODE

3 = 0.30mm A = 0.65mm F = 1.25mm L = 3.20mm S = 1.35mm
 5 = 0.50mm C = 0.85mm H = 1.60mm M = 1.15mm U = 1.80mm
 8 = 0.80mm D = 1.00mm I = 2.00mm P = 1.15mm V = 2.50mm
 9 = 0.90mm E = 1.10mm J = 2.50mm Q = 1.25mm Y = 1.25mm

8. INNER ELECTRODE / TERMINATION / PLATING CODE

A=Normal Product Pd / Ag / Ni barrier / Sn 100%
 N=Normal Product Ni / Cu / Ni barrier / Sn 100%
 G=Normal Product Cu / Cu / Ni barrier / Sn 100%
 L=Low profile Ni / Cu / Ni barrier / Sn 100%
 S=Normal Product Ni/Cu/Ag-Epoxy/Ni barrier / Sn 100%

9. PRODUCT CODE

A= Array(2-element) L=LICC
 B= Array(4-element) N=Normal

| Size Code | *Size tolerance | | | |
|-----------|-----------------|------------|------------|------------|
| | 0201(0603) | 0402(1005) | 0603(1608) | 0805(2012) |
| S | ±0.05 | ±0.07 | ±0.07 | - |
| Q | ±0.07 | ±0.1 | ±0.15 | ±0.15 |
| R | ±0.1 | ±0.15 | ±0.2 | ±0.2 |
| U | - | ±0.2 | - | - |

10. SPECIAL CODE

N= special code

11. PACKAGING CODE

B = Bulk O = Cardboard Tape, 10" Reel E = Embossed Type, 7" Reel
 P = Bulk Case D = Cardboard Tape, 13" Reel(10,000ea) F = Embossed Type, 13" Reel
 C = Cardboard Tape, 7" Reel L = Cardboard Tape, 13" Reel(15,000ea) S = Embossed Type, 10" Reel

Class I (Temperature Compensation)

| Symbol | EIA Code | Operation Temperature Range(°C) | Temperature Coefficient Range(ppm/°C) |
|--------|----------|---------------------------------|---------------------------------------|
| C | COG | -55 ~ +125 | 0 ±30 |

* Class II (High Dielectric Constant)

| Symbol | EIA Code | Operation Temperature Range(°C) | Capacitance Change(ΔC %) |
|--------|----------|---------------------------------|--------------------------|
| A | X5R | -55 ~ +85 | ±15 |
| B | X7R | -55 ~ +125 | ±15 |
| X | X6S | -55 ~ +105 | ±22 |
| F | Y5V | -30 ~ +85 | -82 ~ +22 |
| Y | X7S | -55 ~ +125 | ±22 |

**

| Series | TC | Capacitance Step | | | | | | | | | | | | | | | | | |
|--------|-------------------|------------------|-----|-----|-----|-----|-----|-----|-----|-----|-----|-----|-----|-----|--|--|-----|--|--|
| | | 1.0 | | | 1.5 | | | 2.2 | | | 3.3 | | | | | | | | |
| E-3 | Y5V | 1.0 | | | 2.2 | | | 4.7 | | | | | | | | | | | |
| E-6 | X5R X7R X6S | 1.0 | | | 1.5 | | | 2.2 | | | 3.3 | | | 4.7 | | | 6.8 | | |
| E-12 | COG | 1.0 | 1.2 | 1.5 | 1.8 | 2.2 | 2.7 | 3.3 | 3.9 | 4.7 | 5.6 | 6.8 | 8.2 | | | | | | |

| Size | Code | Thickness(mm) | Spec(mm) | Size | Code | Thickness(mm) | Spec(mm) |
|-------------|------|---------------|-----------|------------|------|---------------|----------|
| 01005(0402) | 2 | 0.20 | ±0.02 | 1210(3225) | H | 1.60 | ±0.20 |
| 0201(0603) | 3 | 0.30 | ±0.03 | | U | 1.80 | ±0.20 |
| 0402(1005) | 5 | 0.50 | ±0.05 | | I | 2.00 | ±0.20 |
| 0603(1608) | 5 | 0.50 | +0.0/-0.1 | | J | 2.50 | ±0.20 |
| | 8 | 0.80 | ±0.10 | V | 2.50 | ±0.30 | |
| 0805(2012) | A | 0.65 | ±0.10 | 1808(4520) | F | 1.25 | ±0.20 |
| | C | 0.85 | ±0.10 | | H | 1.60 | ±0.20 |
| | D | 1.00 | ±0.15 | | I | 2.00 | ±0.20 |
| | F | 1.25 | ±0.10 | | | | |
| | Q | 1.25 | ±0.15 | | | | |
| 1206(3216) | Y | 1.25 | ±0.2 | 1812(4532) | F | 1.25 | ±0.20 |
| | C | 0.85 | ±0.15 | | H | 1.60 | ±0.20 |
| | D | 1.00 | ±0.15 | | I | 2.00 | ±0.20 |
| | E | 1.10 | ±0.10 | | J | 2.50 | ±0.20 |
| | P | 1.15 | ±0.10 | | L | 3.20 | ±0.30 |
| | F | 1.25 | ±0.15 | | | | |
| 1210(3225) | H | 1.60 | ±0.20 | 2220(5750) | F | 1.25 | ±0.20 |
| | C | 0.85 | ±0.15 | | H | 1.60 | ±0.20 |
| | 9 | 0.90 | ±0.10 | | I | 2.00 | ±0.20 |
| | M | 1.15 | ±0.10 | | J | 2.50 | ±0.20 |
| | F | 1.25 | ±0.20 | | L | 3.20 | ±0.30 |
| S | 1.35 | ±0.15 | | | | | |

- * Mark is only applicable to "L" code, 12th code in part number.
- Please discuss with sales person with regard to Pd products.

Part Numbering System

General Capacitors

High Capacitance Capacitors

Super Small Size Capacitors

Medium-High Voltage Capacitors

Array Type Capacitors

Low ESL Capacitors

Reliability Test Condition

Premium Capacitors for Automotive Applications

Packaging Specification

Application Manual for Surface Mounting

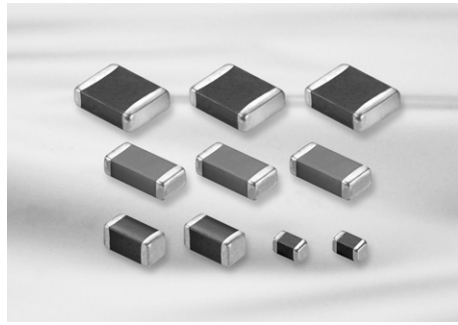

Feature

- Wide selection of size : from 0402 to 2220
- Highly reliable tolerance and high speed automatic chip placement on PCBs
- Wide capacitance range
- Wide temperature compensation and voltage range : from COG to Y5V and from 6.3V to 50V
- Highly reliable performance
- Highly resistant termination metal
- Tape & reel for surface mount assembly

Application

- HHP, DSC, DVC, LCD, TV, Car Navigation, Memory Module, PDA, Game Machine
- Tuner (Product code C is suitable.)
- ※ Medical, Aviation, Automobile device should be following a special specification.

Structure and Dimensions

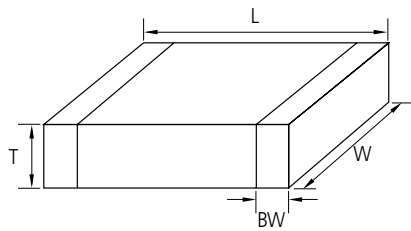

| Size Code | EIA Code | Dimension(mm) | | | | |
|-----------|----------|---------------|-----------|---------------|----------------|---------------|
| | | L | W | T | Thickness Code | BW |
| 05 | 0402 | 1.00±0.05 | 0.50±0.05 | 0.50±0.05 | 5 | 0.2+0.15/-0.1 |
| 10 | 0603 | 1.60±0.10 | 0.80±0.10 | 0.50+0.0/-0.1 | 5 | 0.30±0.20 |
| | | | | 0.80±0.10 | 8 | |
| 21 | 0805 | 2.00±0.10 | 1.25±0.10 | 0.85±0.10 | C | 0.5+0.2/-0.3 |
| | | | | 1.25±0.10 | F | |
| | | | | 1.25±0.15 | Q | |
| | | 2.00±0.15 | 1.25±0.15 | 1.25±0.15 | Y | |
| | | 2.00±0.20 | 1.25±0.20 | 1.25±0.20 | Y | |
| 31 | 1206 | 3.20±0.20 | 1.60±0.20 | 0.60±0.10 | 6 | 0.50±0.30 |
| | | | | 0.85±0.15 | C | |
| | | | | 0.85±0.10(*) | | |
| | | | | 1.15±0.10 | P | |
| | | 3.20±0.15 | 1.60±0.15 | 1.25±0.15 | F | |
| | | 3.20±0.20 | 1.60±0.20 | 1.60±0.20 | H | |
| 32 | 1210 | 3.20±0.30 | 2.50±0.20 | 0.85±0.15 | C | 0.60±0.30 |
| | | | | 0.85±0.10(*) | | |
| | | | | 0.90±0.10 | 9 | |
| | | | | 1.60±0.20 | H | |
| | | | | 1.80±0.20 | U | |
| | | | | 2.00±0.20 | I | |
| | | 2.50±0.20 | J | | | |
| | | 3.20±0.40 | 2.50±0.30 | 2.50±0.30 | v | |
| 42 | 1808 | 4.50±0.40 | 2.00±0.20 | 2.00±0.20 | I | 0.80±0.30 |
| 43 | 1812 | 4.50±0.40 | 3.20±0.30 | 3.20±0.30 | L | 0.80±0.30 |
| 55 | 2220 | 5.70±0.40 | 5.00±0.40 | 3.20±0.30 | L | 1.00±0.30 |

■ * Mark is only applicable to "L" code , 12th code in part number.

General Capacitors Table (COG)

| Size(mm) | Vr(V) | Capacitance | | | | | | | | | | | | | | | | | | | | | |
|------------|-------|---|---|----|----|----|-----|-----|-----|-----|-----|----|-----|-----|-----|-----|----|----|----|----|----|----|-----|
| | | pF | | | | | | | | | | nF | | | | | | | | | | | |
| | | 0.5 | 1 | 10 | 22 | 47 | 100 | 220 | 330 | 470 | 560 | 1 | 2.2 | 3.3 | 4.7 | 6.8 | 10 | 22 | 27 | 33 | 47 | 68 | 100 |
| 0402(1005) | 25 | [Bar chart showing capacitance availability for 0402(1005) at 25V] | | | | | | | | | | | | | | | | | | | | | |
| | 50 | [Bar chart showing capacitance availability for 0402(1005) at 50V] | | | | | | | | | | | | | | | | | | | | | |
| 0603(1608) | 25 | [Bar chart showing capacitance availability for 0603(1608) at 25V] | | | | | | | | | | | | | | | | | | | | | |
| | 50 | [Bar chart showing capacitance availability for 0603(1608) at 50V] | | | | | | | | | | | | | | | | | | | | | |
| 0805(2012) | 25 | [Bar chart showing capacitance availability for 0805(2012) at 25V] | | | | | | | | | | | | | | | | | | | | | |
| | 50 | [Bar chart showing capacitance availability for 0805(2012) at 50V] | | | | | | | | | | | | | | | | | | | | | |
| 1206(3216) | 16 | [Bar chart showing capacitance availability for 1206(3216) at 16V] | | | | | | | | | | | | | | | | | | | | | |
| | 25 | [Bar chart showing capacitance availability for 1206(3216) at 25V] | | | | | | | | | | | | | | | | | | | | | |
| | 50 | [Bar chart showing capacitance availability for 1206(3216) at 50V] | | | | | | | | | | | | | | | | | | | | | |
| 1210(3225) | 50 | [Bar chart showing capacitance availability for 1210(3225) at 50V] | | | | | | | | | | | | | | | | | | | | | |
| 1812(4532) | 25 | [Bar chart showing capacitance availability for 1812(4532) at 25V] | | | | | | | | | | | | | | | | | | | | | |
| | 50 | [Bar chart showing capacitance availability for 1812(4532) at 50V] | | | | | | | | | | | | | | | | | | | | | |
| 2220(5750) | 50 | [Bar chart showing capacitance availability for 2220(5750) at 50V, with 43nF and 130nF highlighted] | | | | | | | | | | | | | | | | | | | | | |

- Part Numbering System
- General Capacitors
- High Capacitance Capacitors
- Super Small Size Capacitors
- Medium-High Voltage Capacitors
- Array Type Capacitors
- Low ESL Capacitors
- Reliability Test Condition
- Premium Capacitors for Automotive Applications
- Packaging Specification
- Application Manual for Surface Mounting

General Capacitors Table (X5R)

| Size(mm) | Vr(V) | Capacitance (uF) | | | | | | | | | | |
|------------|------------|--|--|------|---|-----|-----|----|----|----|-----|--|
| | | 0.1 | 0.22 | 0.47 | 1 | 2.2 | 4.7 | 10 | 22 | 47 | 100 | |
| 0402(1005) | 4 | [Bar chart showing capacitance values for 0.1 to 100 uF] | | | | | | | | | | |
| | 6.3 | [Bar chart showing capacitance values for 0.1 to 100 uF] | | | | | | | | | | |
| | 10 | [Bar chart showing capacitance values for 0.1 to 100 uF] | | | | | | | | | | |
| | 16 | [Bar chart showing capacitance values for 0.1 to 100 uF] | | | | | | | | | | |
| | 25 | [Bar chart showing capacitance values for 0.1 to 100 uF] | | | | | | | | | | |
| 0603(1608) | 4 | [Bar chart showing capacitance values for 0.1 to 100 uF] | | | | | | | | | | |
| | 6.3 | [Bar chart showing capacitance values for 0.1 to 100 uF] | | | | | | | | | | |
| | 10 | [Bar chart showing capacitance values for 0.1 to 100 uF] | | | | | | | | | | |
| | 16 | [Bar chart showing capacitance values for 0.1 to 100 uF] | | | | | | | | | | |
| | 25 | [Bar chart showing capacitance values for 0.1 to 100 uF] | | | | | | | | | | |
| | 50 | [Bar chart showing capacitance values for 0.1 to 100 uF] | | | | | | | | | | |
| 0805(2012) | 4 | [Bar chart showing capacitance values for 0.1 to 100 uF] | | | | | | | | | | |
| | 6.3 | [Bar chart showing capacitance values for 0.1 to 100 uF] | | | | | | | | | | |
| | 10 | [Bar chart showing capacitance values for 0.1 to 100 uF] | | | | | | | | | | |
| | 16 | [Bar chart showing capacitance values for 0.1 to 100 uF] | | | | | | | | | | |
| | 25 | [Bar chart showing capacitance values for 0.1 to 100 uF] | | | | | | | | | | |
| | 50 | [Bar chart showing capacitance values for 0.1 to 100 uF] | | | | | | | | | | |
| 1206(3216) | 6.3 | [Bar chart showing capacitance values for 0.1 to 100 uF] | | | | | | | | | | |
| | 10 | [Bar chart showing capacitance values for 0.1 to 100 uF] | | | | | | | | | | |
| | 16 | [Bar chart showing capacitance values for 0.1 to 100 uF] | | | | | | | | | | |
| | 25 | [Bar chart showing capacitance values for 0.1 to 100 uF] | | | | | | | | | | |
| | 50 | [Bar chart showing capacitance values for 0.1 to 100 uF] | | | | | | | | | | |
| | 1210(3225) | 6.3 | [Bar chart showing capacitance values for 0.1 to 100 uF] | | | | | | | | | |
| | 10 | [Bar chart showing capacitance values for 0.1 to 100 uF] | | | | | | | | | | |
| | 16 | [Bar chart showing capacitance values for 0.1 to 100 uF] | | | | | | | | | | |
| | 25 | [Bar chart showing capacitance values for 0.1 to 100 uF] | | | | | | | | | | |

General Capacitors Table_Low Profile (X5R)

| Size(mm) | Tmax (mm) | Vr(V) | Capacitance (uF) | | | | | | | |
|------------|-----------|-------|---|-----|-----|----|----|----|----|--|
| | | | 1 | 2.2 | 4.7 | 10 | 22 | 33 | 47 | |
| 0402(1005) | 0.3 | 6.3 | [Bar chart showing capacitance values for 1 to 47 uF] | | | | | | | |
| | | 10 | [Bar chart showing capacitance values for 1 to 47 uF] | | | | | | | |
| | | 16 | [Bar chart showing capacitance values for 1 to 47 uF] | | | | | | | |
| 0603(1608) | 0.5 | 6.3 | [Bar chart showing capacitance values for 1 to 47 uF] | | | | | | | |
| | | 10 | [Bar chart showing capacitance values for 1 to 47 uF] | | | | | | | |
| | | 16 | [Bar chart showing capacitance values for 1 to 47 uF] | | | | | | | |
| | 0.5 | 10 | [Bar chart showing capacitance values for 1 to 47 uF] | | | | | | | |
| | | 16 | [Bar chart showing capacitance values for 1 to 47 uF] | | | | | | | |
| | | 25 | [Bar chart showing capacitance values for 1 to 47 uF] | | | | | | | |
| 0805(2012) | 0.95 | 4 | [Bar chart showing capacitance values for 1 to 47 uF] | | | | | | | |
| | | 6.3 | [Bar chart showing capacitance values for 1 to 47 uF] | | | | | | | |
| | | 10 | [Bar chart showing capacitance values for 1 to 47 uF] | | | | | | | |
| | 0.7 | 16 | [Bar chart showing capacitance values for 1 to 47 uF] | | | | | | | |
| | | 25 | [Bar chart showing capacitance values for 1 to 47 uF] | | | | | | | |
| | | 50 | [Bar chart showing capacitance values for 1 to 47 uF] | | | | | | | |
| 1206(3216) | 0.95 | 6.3 | [Bar chart showing capacitance values for 1 to 47 uF] | | | | | | | |
| | | 10 | [Bar chart showing capacitance values for 1 to 47 uF] | | | | | | | |
| | | 16 | [Bar chart showing capacitance values for 1 to 47 uF] | | | | | | | |
| | | 25 | [Bar chart showing capacitance values for 1 to 47 uF] | | | | | | | |
| | | 50 | [Bar chart showing capacitance values for 1 to 47 uF] | | | | | | | |
| 1210(3225) | 2.0 | 16 | [Bar chart showing capacitance values for 1 to 47 uF] | | | | | | | |
| | | 25 | [Bar chart showing capacitance values for 1 to 47 uF] | | | | | | | |
| | | 50 | [Bar chart showing capacitance values for 1 to 47 uF] | | | | | | | |

Part Numbering System

General Capacitors

High Capacitance Capacitors

Super Small Size Capacitors

Medium-High Voltage Capacitors

Array Type Capacitors

Low ESL Capacitors

Reliability Test Condition

Premium Capacitors for Automotive Applications

Packaging Specification

Application Manual for Surface Mounting

General Capacitors Table (X6S)

| Size(mm) | Vr(V) | Capacitance (uF) | | | | | | | | | | |
|------------|-------|------------------|------|------|---|-----|-----|----|----|----|-----|--|
| | | 0.1 | 0.22 | 0.47 | 1 | 2.2 | 4.7 | 10 | 22 | 47 | 100 | |
| 0402(1005) | 4 | | | | | | | | | | | |
| | 6.3 | | | | | | | | | | | |
| | 10 | | | | | | | | | | | |
| 0603(1608) | 4 | | | | | | | | | | | |
| | 6.3 | | | | | | | | | | | |
| | 10 | | | | | | | | | | | |
| | 16 | | | | | | | | | | | |
| | 25 | | | | | | | | | | | |
| 0805(2012) | 4 | | | | | | | | | | | |
| | 6.3 | | | | | | | | | | | |
| | 10 | | | | | | | | | | | |
| | 16 | | | | | | | | | | | |
| | 25 | | | | | | | | | | | |
| 1206(3216) | 6.3 | | | | | | | | | | | |
| | 10 | | | | | | | | | | | |
| | 16 | | | | | | | | | | | |
| | 25 | | | | | | | | | | | |
| 1210(3225) | 6.3 | | | | | | | | | | | |
| | 10 | | | | | | | | | | | |
| | 16 | | | | | | | | | | | |
| | 25 | | | | | | | | | | | |

General Capacitors Table (X7R)

| Size(mm) | Vr(V) | Capacitance (uF) | | | | | | | | | | |
|------------|-------|------------------|------|------|---|-----|-----|----|----|----|-----|--|
| | | 0.1 | 0.22 | 0.47 | 1 | 2.2 | 4.7 | 10 | 22 | 47 | 100 | |
| 0402(1005) | 6.3 | | | | | | | | | | | |
| | 10 | | | | | | | | | | | |
| | 16 | | | | | | | | | | | |
| 0603(1608) | 6.3 | | | | | | | | | | | |
| | 10 | | | | | | | | | | | |
| | 16 | | | | | | | | | | | |
| | 25 | | | | | | | | | | | |
| | 50 | | | | | | | | | | | |
| 0805(2012) | 6.3 | | | | | | | | | | | |
| | 10 | | | | | | | | | | | |
| | 16 | | | | | | | | | | | |
| | 25 | | | | | | | | | | | |
| | 35 | | | | | | | | | | | |
| | 50 | | | | | | | | | | | |
| 1206(3216) | 6.3 | | | | | | | | | | | |
| | 10 | | | | | | | | | | | |
| | 16 | | | | | | | | | | | |
| | 25 | | | | | | | | | | | |
| 1210(3225) | 6.3 | | | | | | | | | | | |
| | 10 | | | | | | | | | | | |
| | 16 | | | | | | | | | | | |
| | 25 | | | | | | | | | | | |
| | 50 | | | | | | | | | | | |

Part Numbering System

General Capacitors

High Capacitance Capacitors

Super Small Size Capacitors

Medium-High Voltage Capacitors

Array Type Capacitors

Low ESL Capacitors

Reliability Test Condition

Premium Capacitors for Automotive Applications

Packaging Specification

Application Manual for Surface Mounting

General Capacitors Table (Y5V)

| Size(mm) | Vr(V) | Capacitance (uF) | | | | | | | | | |
|------------|-------|------------------|------|------|---|-----|-----|----|----|----|--|
| | | 0.1 | 0.22 | 0.47 | 1 | 2.2 | 4.7 | 10 | 22 | 47 | |
| 0402(1005) | 6.3 | | | | | | | | | | |
| | 10 | | | | | | | | | | |
| | 16 | | | | | | | | | | |
| | 6.3 | | | | | | | | | | |
| 0603(1608) | 6.3 | | | | | | | | | | |
| | 10 | | | | | | | | | | |
| | 16 | | | | | | | | | | |
| | 25 | | | | | | | | | | |
| | 50 | | | | | | | | | | |
| 0805(2012) | 6.3 | | | | | | | | | | |
| | 10 | | | | | | | | | | |
| | 16 | | | | | | | | | | |
| | 25 | | | | | | | | | | |
| | 50 | | | | | | | | | | |
| 1206(3216) | 6.3 | | | | | | | | | | |
| | 10 | | | | | | | | | | |
| | 16 | | | | | | | | | | |
| | 25 | | | | | | | | | | |
| | 50 | | | | | | | | | | |
| 1210(3225) | 6.3 | | | | | | | | | | |
| | 10 | | | | | | | | | | |
| | 16 | | | | | | | | | | |
| | 25 | | | | | | | | | | |
| | 35 | | | | | | | | | | |
| | 50 | | | | | | | | | | |
| | 50 | | | | | | | | | | |

Product Lineup (General Capacitors-C0G)

| | Part Number | Size L×W (mm) | Capacitance | Rated Voltage (Vdc) | Capacitance Tolerance | Thickness Max. (mm) |
|----|------------------|---------------|-------------|---------------------|-----------------------|---------------------|
| 1 | CL05C0R5CB5NNN □ | 1.00×0.50 | 0.5pF | 50 | ±0.25pF | 0.55 |
| 2 | CL05CR75CB5NNN □ | | 0.75pF | 50 | ±0.25pF | 0.55 |
| 3 | CL05C010CB5NNN □ | | 1.0pF | 50 | ±0.25pF | 0.55 |
| 4 | CL05C1R2CB5NNN □ | | 1.2pF | 50 | ±0.25pF | 0.55 |
| 5 | CL05C1R5CB5NNN □ | | 1.5pF | 50 | ±0.25pF | 0.55 |
| 6 | CL05C1R8CB5NNN □ | | 1.8pF | 50 | ±0.25pF | 0.55 |
| 7 | CL05C020CB5NNN □ | | 2.0pF | 50 | ±0.25pF | 0.55 |
| 8 | CL05C2R2CB5NNN □ | | 2.2pF | 50 | ±0.25pF | 0.55 |
| 9 | CL05C2R4CB5NNN □ | | 2.4pF | 50 | ±0.25pF | 0.55 |
| 10 | CL05C2R5CB5NNN □ | | 2.5pF | 50 | ±0.25pF | 0.55 |
| 11 | CL05C2R7CB5NNN □ | | 2.7pF | 50 | ±0.25pF | 0.55 |
| 12 | CL05C030CB5NNN □ | | 3.0pF | 50 | ±0.25pF | 0.55 |
| 13 | CL05C3R3CB5NNN □ | | 3.3pF | 50 | ±0.25pF | 0.55 |
| 14 | CL05C3R5CB5NNN □ | | 3.5pF | 50 | ±0.25pF | 0.55 |
| 15 | CL05C3R6CB5NNN □ | | 3.6pF | 50 | ±0.25pF | 0.55 |
| 16 | CL05C3R9CB5NNN □ | | 3.9pF | 50 | ±0.25pF | 0.55 |
| 17 | CL05C040CB5NNN □ | | 4.0pF | 50 | ±0.25pF | 0.55 |
| 18 | CL05C4R3CB5NNN □ | | 4.3pF | 50 | ±0.25pF | 0.55 |
| 19 | CL05C4R7CB5NNN □ | | 4.7pF | 50 | ±0.25pF | 0.55 |
| 20 | CL05C050DB5NNN □ | | 5.0pF | 50 | ±0.5pF | 0.55 |
| 21 | CL05C5R6DB5NNN □ | | 5.6pF | 50 | ±0.5pF | 0.55 |
| 22 | CL05C060DB5NNN □ | | 6.0pF | 50 | ±0.5pF | 0.55 |
| 23 | CL05C6R2DB5NNN □ | | 6.2pF | 50 | ±0.5pF | 0.55 |
| 24 | CL05C6R8DB5NNN □ | | 6.8pF | 50 | ±0.5pF | 0.55 |
| 25 | CL05C070DB5NNN □ | | 7.0pF | 50 | ±0.5pF | 0.55 |
| 26 | CL05C080DB5NNN □ | | 8.0pF | 50 | ±0.5pF | 0.55 |
| 27 | CL05C8R2DB5NNN □ | | 8.2pF | 50 | ±0.5pF | 0.55 |
| 28 | CL05C090DB5NNN □ | | 9.0pF | 50 | ±0.5pF | 0.55 |
| 29 | CL05C9R1DB5NNN □ | | 9.1pF | 50 | ±0.5pF | 0.55 |
| 30 | CL05C100JB5NNN □ | | 10pF | 50 | ±5% | 0.55 |
| 31 | CL05C110JB5NNN □ | | 11pF | 50 | ±5% | 0.55 |
| 32 | CL05C120JB5NNN □ | | 12pF | 50 | ±5% | 0.55 |
| 33 | CL05C130JB5NNN □ | | 13pF | 50 | ±5% | 0.55 |
| 34 | CL05C150JB5NNN □ | | 15pF | 50 | ±5% | 0.55 |
| 35 | CL05C160JB5NNN □ | | 16pF | 50 | ±5% | 0.55 |
| 36 | CL05C180JB5NNN □ | | 18pF | 50 | ±5% | 0.55 |
| 37 | CL05C200JB5NNN □ | | 20pF | 50 | ±5% | 0.55 |
| 38 | CL05C220JA5NNN □ | | 22pF | 25 | ±5% | 0.55 |
| 39 | CL05C220JB5NNN □ | | 22pF | 50 | ±5% | 0.55 |
| 40 | CL05C240JB5NNN □ | | 24pF | 50 | ±5% | 0.55 |
| 41 | CL05C270JB5NNN □ | | 27pF | 50 | ±5% | 0.55 |
| 42 | CL05C270JA5NNN □ | | 27pF | 25 | ±5% | 0.55 |
| 43 | CL05C300JB5NNN □ | | 30pF | 50 | ±5% | 0.55 |
| 44 | CL05C330JB5NNN □ | | 33pF | 50 | ±5% | 0.55 |
| 45 | CL05C360JB5NNN □ | | 36pF | 50 | ±5% | 0.55 |
| 46 | CL05C390JB5NNN □ | | 39pF | 50 | ±5% | 0.55 |
| 47 | CL05C430JB5NNN □ | | 43pF | 50 | ±5% | 0.55 |
| 48 | CL05C470JB5NNN □ | | 47pF | 50 | ±5% | 0.55 |
| 49 | CL05C510JB5NNN □ | | 51pF | 50 | ±5% | 0.55 |
| 50 | CL05C560JB5NNN □ | | 56pF | 50 | ±5% | 0.55 |

※ □ mark means packaging code. If you want to learn the code or quantity in detail, please see p80.

- Part Numbering System
- General Capacitors
- High Capacitance Capacitors
- Super Small Size Capacitors
- Medium-High Voltage Capacitors
- Array Type Capacitors
- Low ESL Capacitors
- Reliability Test Condition
- Premium Capacitors for Automotive Applications
- Packaging Specification
- Application Manual for Surface Mounting

Product Lineup (General Capacitors-C0G)

| | Part Number | Size L × W (mm) | Capacitance | Rated Voltage (Vdc) | Capacitance Tolerance | Thickness Max. (mm) |
|----|------------------|-----------------|-------------|---------------------|-----------------------|---------------------|
| 51 | CL05C620JB5NNN □ | 1.00×0.50 | 62pF | 50 | ±5% | 0.55 |
| 52 | CL05C680JB5NNN □ | | 68pF | 50 | ±5% | 0.55 |
| 53 | CL05C750JB5NNN □ | | 75pF | 50 | ±5% | 0.55 |
| 54 | CL05C820JB5NNN □ | | 82pF | 50 | ±5% | 0.55 |
| 55 | CL05C910JB5NNN □ | | 91pF | 50 | ±5% | 0.55 |
| 56 | CL05C101JB5NNN □ | | 100pF | 50 | ±5% | 0.55 |
| 57 | CL05C121JB5NNN □ | | 120pF | 50 | ±5% | 0.55 |
| 58 | CL05C151JB5NNN □ | | 150pF | 50 | ±5% | 0.55 |
| 59 | CL05C181JB5NNN □ | | 180pF | 50 | ±5% | 0.55 |
| 60 | CL05C201JB5NNN □ | | 200pF | 50 | ±5% | 0.55 |
| 61 | CL05C221JB5NNN □ | | 220pF | 50 | ±5% | 0.55 |
| 62 | CL05C271JB5NNN □ | | 270pF | 50 | ±5% | 0.55 |
| 63 | CL05C331JB5NNN □ | | 330pF | 50 | ±5% | 0.55 |
| 64 | CL05C391JB5NNN □ | | 390pF | 50 | ±5% | 0.55 |
| 65 | CL05C471JB5NNN □ | | 470pF | 50 | ±5% | 0.55 |
| 66 | CL05C471JO5NNN □ | | 470pF | 16 | ±5% | 0.55 |
| 67 | CL05C681JB5NNN □ | | 680pF | 50 | ±5% | 0.55 |
| 68 | CL05C821JB5NNN □ | | 820pF | 50 | ±5% | 0.55 |
| 69 | CL05C102JB5NNN □ | | 1nF | 50 | ±5% | 0.55 |
| 70 | CL05C102JA5NNN □ | | 1nF | 25 | ±5% | 0.55 |
| 71 | CL05C102JO5NNN □ | | 1nF | 16 | ±5% | 0.55 |
| 1 | CL10C0R3CB8NNN □ | 1.60×0.80 | 0.3pF | 50 | ±0.25pF | 0.90 |
| 2 | CL10C0R5CB8NNN □ | | 0.5pF | 50 | ±0.25pF | 0.90 |
| 3 | CL10CR75CB8NNN □ | | 0.75pF | 50 | ±0.25pF | 0.90 |
| 4 | CL10C010CB8NNN □ | | 1.0pF | 50 | ±0.25pF | 0.90 |
| 5 | CL10C1R2CB8NNN □ | | 1.2pF | 50 | ±0.25pF | 0.90 |
| 6 | CL10C1R5CB8NNN □ | | 1.5pF | 50 | ±0.25pF | 0.90 |
| 7 | CL10C1R8CB8NNN □ | | 1.8pF | 50 | ±0.25pF | 0.90 |
| 8 | CL10C020CB8NNN □ | | 2.0pF | 50 | ±0.25pF | 0.90 |
| 9 | CL10C2R2CB8NNN □ | | 2.2pF | 50 | ±0.25pF | 0.90 |
| 10 | CL10C2R4CB8NNN □ | | 2.4pF | 50 | ±0.25pF | 0.90 |
| 11 | CL10C2R5CB8NNN □ | | 2.5pF | 50 | ±0.25pF | 0.90 |
| 12 | CL10C2R7CB8NNN □ | | 2.7pF | 50 | ±0.25pF | 0.90 |
| 13 | CL10C030CB8NNN □ | | 3.0pF | 50 | ±0.25pF | 0.90 |
| 14 | CL10C3R3CB8NNN □ | | 3.3pF | 50 | ±0.25pF | 0.90 |
| 15 | CL10C3R5CB8NNN □ | | 3.5pF | 50 | ±0.25pF | 0.90 |
| 16 | CL10C3R6CB8NNN □ | | 3.6pF | 50 | ±0.25pF | 0.90 |
| 17 | CL10C3R9CB8NNN □ | | 3.9pF | 50 | ±0.25pF | 0.90 |
| 18 | CL10C040CB8NNN □ | | 4.0pF | 50 | ±0.25pF | 0.90 |
| 19 | CL10C4R3CB8NNN □ | | 4.3pF | 50 | ±0.25pF | 0.90 |
| 20 | CL10C4R7CB8NNN □ | | 4.7pF | 50 | ±0.25pF | 0.90 |
| 21 | CL10C050DB8NNN □ | | 5.0pF | 50 | ±0.5pF | 0.90 |
| 22 | CL10C5R6DB8NNN □ | | 5.6pF | 50 | ±0.5pF | 0.90 |
| 23 | CL10C060DB8NNN □ | | 6.0pF | 50 | ±0.5pF | 0.90 |
| 24 | CL10C6R2DB8NNN □ | | 6.2pF | 50 | ±0.5pF | 0.90 |
| 25 | CL10C6R8DB8NNN □ | | 6.8pF | 50 | ±0.5pF | 0.90 |
| 26 | CL10C070DB8NNN □ | | 7.0pF | 50 | ±0.5pF | 0.90 |
| 27 | CL10C7R5DB8NNN □ | | 7.5pF | 50 | ±0.5pF | 0.90 |
| 28 | CL10C080DB8NNN □ | | 8.0pF | 50 | ±0.5pF | 0.90 |
| 29 | CL10C8R2DB8NNN □ | 8.2pF | 50 | ±0.5pF | 0.90 | |

※ □mark means packaging code. If you want to learn the code or quantity in detail, please see p80.

Product Lineup (General Capacitors-C0G)

| | Part Number | Size L × W (mm) | Capacitance | Rated Voltage (Vdc) | Capacitance Tolerance | Thickness Max. (mm) |
|----|------------------|-----------------|-------------|---------------------|-----------------------|---------------------|
| 30 | CL10C090DB8NNN □ | 1.60×0.80 | 9.0pF | 50 | ±0.5pF | 0.90 |
| 31 | CL10C9R1DB8NNN □ | | 9.1pF | 50 | ±0.5pF | 0.90 |
| 32 | CL10C100JB8NNN □ | | 10pF | 50 | ±5% | 0.90 |
| 33 | CL10C110JB8NNN □ | | 11pF | 50 | ±5% | 0.90 |
| 34 | CL10C120JB8NNN □ | | 12pF | 50 | ±5% | 0.90 |
| 35 | CL10C130JB8NNN □ | | 13pF | 50 | ±5% | 0.90 |
| 36 | CL10C140JB8NNN □ | | 14pF | 50 | ±5% | 0.90 |
| 37 | CL10C150JB8NNN □ | | 15pF | 50 | ±5% | 0.90 |
| 38 | CL10C160JB8NNN □ | | 16pF | 50 | ±5% | 0.90 |
| 39 | CL10C180JB8NNN □ | | 18pF | 50 | ±5% | 0.90 |
| 40 | CL10C200JB8NNN □ | | 20pF | 50 | ±5% | 0.90 |
| 41 | CL10C220JB8NNN □ | | 22pF | 50 | ±5% | 0.90 |
| 42 | CL10C240JB8NNN □ | | 24pF | 50 | ±5% | 0.90 |
| 43 | CL10C250JB8NNN □ | | 25pF | 50 | ±5% | 0.90 |
| 44 | CL10C270JB8NNN □ | | 27pF | 50 | ±5% | 0.90 |
| 45 | CL10C300JB8NNN □ | | 30pF | 50 | ±5% | 0.90 |
| 46 | CL10C330JB8NNN □ | | 33pF | 50 | ±5% | 0.90 |
| 47 | CL10C360JB8NNN □ | | 36pF | 50 | ±5% | 0.90 |
| 48 | CL10C390JB8NNN □ | | 39pF | 50 | ±5% | 0.90 |
| 49 | CL10C430JB8NNN □ | | 43pF | 50 | ±5% | 0.90 |
| 50 | CL10C470JB8NNN □ | | 47pF | 50 | ±5% | 0.90 |
| 51 | CL10C510JB8NNN □ | | 51pF | 50 | ±5% | 0.90 |
| 52 | CL10C560JB8NNN □ | | 56pF | 50 | ±5% | 0.90 |
| 53 | CL10C620JB8NNN □ | | 62pF | 50 | ±5% | 0.90 |
| 54 | CL10C680JB8NNN □ | | 68pF | 50 | ±5% | 0.90 |
| 55 | CL10C750JB8NNN □ | | 75pF | 50 | ±5% | 0.90 |
| 56 | CL10C820JB8NNN □ | | 82pF | 50 | ±5% | 0.90 |
| 57 | CL10C910JB8NNN □ | | 91pF | 50 | ±5% | 0.90 |
| 58 | CL10C101JB8NNN □ | | 100pF | 50 | ±5% | 0.90 |
| 59 | CL10C111JB8NNN □ | 110pF | 50 | ±5% | 0.90 | |
| 60 | CL10C121JB8NNN □ | 120pF | 50 | ±5% | 0.90 | |
| 61 | CL10C131JB8NNN □ | 130pF | 50 | ±5% | 0.90 | |
| 62 | CL10C151JB8NNN □ | 150pF | 50 | ±5% | 0.90 | |
| 63 | CL10C161JB8NNN □ | 160pF | 50 | ±5% | 0.90 | |
| 64 | CL10C181JB8NNN □ | 180pF | 50 | ±5% | 0.90 | |
| 65 | CL10C201JB8NNN □ | 200pF | 50 | ±5% | 0.90 | |
| 66 | CL10C221JB8NNN □ | 220pF | 50 | ±5% | 0.90 | |
| 67 | CL10C241JB8NNN □ | 240pF | 50 | ±5% | 0.90 | |
| 68 | CL10C271JB8NNN □ | 270pF | 50 | ±5% | 0.90 | |
| 69 | CL10C301JB8NNN □ | 300pF | 50 | ±5% | 0.90 | |
| 70 | CL10C331JB8NNN □ | 330pF | 50 | ±5% | 0.90 | |
| 71 | CL10C361JB8NNN □ | 360pF | 50 | ±5% | 0.90 | |
| 72 | CL10C391JB8NNN □ | 390pF | 50 | ±5% | 0.90 | |
| 73 | CL10C431JB8NNN □ | 430pF | 50 | ±5% | 0.90 | |
| 74 | CL10C471JB8NNN □ | 470pF | 50 | ±5% | 0.90 | |
| 75 | CL10C511JB8NNN □ | 510pF | 50 | ±5% | 0.90 | |
| 76 | CL10C561JB8NNN □ | 560pF | 50 | ±5% | 0.90 | |
| 77 | CL10C621JB8NNN □ | 620pF | 50 | ±5% | 0.90 | |
| 78 | CL10C681JB8NNN □ | 680pF | 50 | ±5% | 0.90 | |
| 79 | CL10C751JB8NNN □ | 750pF | 50 | ±5% | 0.90 | |

※ □mark means packaging code. If you want to learn the code or quantity in detail, please see p80.

Part Numbering System

General Capacitors

High Capacitance Capacitors

Super Small Size Capacitors

Medium-High Voltage Capacitors

Array Type Capacitors

Low ESL Capacitors

Reliability Test Condition

Premium Capacitors for Automotive Applications

Packaging Specification

Application Manual for Surface Mounting

Product Lineup (General Capacitors-C0G)

| | Part Number | Size L × W (mm) | Capacitance | Rated Voltage (Vdc) | Capacitance Tolerance | Thickness Max. (mm) |
|----|------------------|-----------------|-------------|---------------------|-----------------------|---------------------|
| 80 | CL10C821JB8NNN □ | 1.60×0.80 | 820pF | 50 | ±5% | 0.90 |
| 81 | CL10C102JB8NNN □ | | 1nF | 50 | ±5% | 0.90 |
| 82 | CL10C182JB8NNN □ | | 1.8nF | 50 | ±5% | 0.90 |
| 83 | CL10C222JB8NNN □ | | 2.2nF | 50 | ±5% | 0.90 |
| 84 | CL10C562JB8NNN □ | | 5.6nF | 50 | ±5% | 0.90 |
| 1 | CL21CR47CBANNN □ | 2.00×1.25 | 0.47pF | 50 | ±0.25pF | 0.75 |
| 2 | CL21C0R5CBANNN □ | | 0.5pF | 50 | ±0.25pF | 0.75 |
| 3 | CL21C010CBANNN □ | | 1.0pF | 50 | ±0.25pF | 0.75 |
| 4 | CL21C1R2CBANNN □ | | 1.2pF | 50 | ±0.25pF | 0.75 |
| 5 | CL21C1R5CBANNN □ | | 1.5pF | 50 | ±0.25pF | 0.75 |
| 6 | CL21C1R8CBANNN □ | | 1.8pF | 50 | ±0.25pF | 0.75 |
| 7 | CL21C020CBANNN □ | | 2.0pF | 50 | ±0.25pF | 0.75 |
| 8 | CL21C2R2CBANNN □ | | 2.2pF | 50 | ±0.25pF | 0.75 |
| 9 | CL21C2R4CBANNN □ | | 2.4pF | 50 | ±0.25pF | 0.75 |
| 10 | CL21C2R5CBANNN □ | | 2.5pF | 50 | ±0.25pF | 0.75 |
| 11 | CL21C2R7CBANNN □ | | 2.7pF | 50 | ±0.25pF | 0.75 |
| 12 | CL21C030CBANNN □ | | 3.0pF | 50 | ±0.25pF | 0.75 |
| 13 | CL21C3R2CBANNN □ | | 3.2pF | 50 | ±0.25pF | 0.75 |
| 14 | CL21C3R3CBANNN □ | | 3.3pF | 50 | ±0.25pF | 0.75 |
| 15 | CL21C3R6CBANNN □ | | 3.6pF | 50 | ±0.25pF | 0.75 |
| 16 | CL21C3R9CBANNN □ | | 3.9pF | 50 | ±0.25pF | 0.75 |
| 17 | CL21C040CBANNN □ | | 4.0pF | 50 | ±0.25pF | 0.75 |
| 18 | CL21C4R7CBANNN □ | | 4.7pF | 50 | ±0.25pF | 0.75 |
| 19 | CL21C5R6DBANNN □ | | 5.6pF | 50 | ±0.5pF | 0.75 |
| 20 | CL21C060DBANNN □ | | 6.0pF | 50 | ±0.5pF | 0.75 |
| 21 | CL21C6R8DBANNN □ | | 6.8pF | 50 | ±0.5pF | 0.75 |
| 22 | CL21C070DBANNN □ | | 7.0pF | 50 | ±0.5pF | 0.75 |
| 23 | CL21C7R5DBANNN □ | | 7.5pF | 50 | ±0.5pF | 0.75 |
| 24 | CL21C080DBANNN □ | | 8.0pF | 50 | ±0.5pF | 0.75 |
| 25 | CL21C8R2DBANNN □ | | 8.2pF | 50 | ±0.5pF | 0.75 |
| 26 | CL21C090DBANNN □ | | 9.0pF | 50 | ±0.5pF | 0.75 |
| 27 | CL21C100JBANNN □ | | 10pF | 50 | ±5% | 0.75 |
| 28 | CL21C120JBANNN □ | | 12pF | 50 | ±5% | 0.75 |
| 29 | CL21C130JBANNN □ | | 13pF | 50 | ±5% | 0.75 |
| 30 | CL21C140JBANNN □ | | 14pF | 50 | ±5% | 0.75 |
| 31 | CL21C150JBANNN □ | | 15pF | 50 | ±5% | 0.75 |
| 32 | CL21C160JBANNN □ | | 16pF | 50 | ±5% | 0.75 |
| 33 | CL21C180JBANNN □ | | 18pF | 50 | ±5% | 0.75 |
| 34 | CL21C200JBANNN □ | | 20pF | 50 | ±5% | 0.75 |
| 35 | CL21C220JBANNN □ | | 22pF | 50 | ±5% | 0.75 |
| 36 | CL21C240JBANNN □ | 24pF | 50 | ±5% | 0.75 | |
| 37 | CL21C250JBANNN □ | 25pF | 50 | ±5% | 0.75 | |
| 38 | CL21C270JBANNN □ | 27pF | 50 | ±5% | 0.75 | |
| 39 | CL21C300JBANNN □ | 30pF | 50 | ±5% | 0.75 | |
| 40 | CL21C330JBANNN □ | 33pF | 50 | ±5% | 0.75 | |
| 41 | CL21C360JBANNN □ | 36pF | 50 | ±5% | 0.75 | |
| 42 | CL21C390JBANNN □ | 39pF | 50 | ±5% | 0.75 | |
| 43 | CL21C430JBANNN □ | 43pF | 50 | ±5% | 0.75 | |
| 44 | CL21C470JBANNN □ | 47pF | 50 | ±5% | 0.75 | |
| 45 | CL21C510JBANNN □ | 51pF | 50 | ±5% | 0.75 | |

※ □ mark means packaging code. If you want to learn the code or quantity in detail, please see p80.

Product Lineup (General Capacitors-C0G)

| | Part Number | Size L × W (mm) | Capacitance | Rated Voltage (Vdc) | Capacitance Tolerance | Thickness Max. (mm) |
|----|-------------------|-----------------|-------------|---------------------|-----------------------|---------------------|
| 46 | CL21C560JBANNN □ | 2.00×1.25 | 56pF | 50 | ±5% | 0.75 |
| 47 | CL21C620JBANNN □ | | 62pF | 50 | ±5% | 0.75 |
| 48 | CL21C680JBANNN □ | | 68pF | 50 | ±5% | 0.75 |
| 49 | CL21C750JBANNN □ | | 75pF | 50 | ±5% | 0.75 |
| 50 | CL21C820JBANNN □ | | 82pF | 50 | ±5% | 0.75 |
| 51 | CL21C910JBANNN □ | | 91pF | 50 | ±5% | 0.75 |
| 52 | CL21C101JBANNN □ | | 100pF | 50 | ±5% | 0.75 |
| 53 | CL21C111JBANNN □ | | 110pF | 50 | ±5% | 0.75 |
| 54 | CL21C121JBANNN □ | | 120pF | 50 | ±5% | 0.75 |
| 55 | CL21C131JBANNN □ | | 130pF | 50 | ±5% | 0.75 |
| 56 | CL21C151JBANNN □ | | 150pF | 50 | ±5% | 0.75 |
| 57 | CL21C161JBANNN □ | | 160pF | 50 | ±5% | 0.75 |
| 58 | CL21C181JBANNN □ | | 180pF | 50 | ±5% | 0.75 |
| 59 | CL21C201JBANNN □ | | 200pF | 50 | ±5% | 0.75 |
| 60 | CL21C221JBANNN □ | | 220pF | 50 | ±5% | 0.75 |
| 61 | CL21C241JBANNN □ | | 240pF | 50 | ±5% | 0.75 |
| 62 | CL21C271JBANNN □ | | 270pF | 50 | ±5% | 0.75 |
| 63 | CL21C301JBANNN □ | | 300pF | 50 | ±5% | 0.75 |
| 64 | CL21C331JBANNN □ | | 330pF | 50 | ±5% | 0.75 |
| 65 | CL21C361JBANNN □ | | 360pF | 50 | ±5% | 0.75 |
| 66 | CL21C391JBANNN □ | | 390pF | 50 | ±5% | 0.75 |
| 67 | CL21C431JBANNN □ | | 430pF | 50 | ±5% | 0.75 |
| 68 | CL21C471JBANNN □ | | 470pF | 50 | ±5% | 0.75 |
| 69 | CL21C511JBANNN □ | | 510pF | 50 | ±5% | 0.75 |
| 70 | CL21C561JBANNN □ | | 560pF | 50 | ±5% | 0.75 |
| 71 | CL21C621JBCN NN □ | | 620pF | 50 | ±5% | 0.95 |
| 72 | CL21C681JBCN NN □ | | 680pF | 50 | ±5% | 0.95 |
| 73 | CL21C751JBCN NN □ | | 750pF | 50 | ±5% | 0.95 |
| 74 | CL21C821JBCN NN □ | | 820pF | 50 | ±5% | 0.95 |
| 75 | CL21C102JBCN NN □ | | 1nF | 50 | ±5% | 0.95 |
| 76 | CL21C122JBFN NN □ | | 1.2nF | 50 | ±5% | 1.35 |
| 77 | CL21C152JBFN NN □ | | 1.5nF | 50 | ±5% | 1.35 |
| 78 | CL21C182JBFN NN □ | | 1.8nF | 50 | ±5% | 1.35 |
| 79 | CL21C222JBFN NN □ | | 2.2nF | 50 | ±5% | 1.35 |
| 80 | CL21C332JAFN NN □ | | 3.3nF | 25 | ±5% | 1.35 |
| 81 | CL21C332JBFN NN □ | 3.3nF | 50 | ±5% | 1.35 | |
| 82 | CL21C392JAAN NN □ | 3.9nF | 25 | ±5% | 0.75 | |
| 83 | CL21C392JBFN NN □ | 3.9nF | 50 | ±5% | 1.35 | |
| 84 | CL21C472JAFN NN □ | 4.7nF | 25 | ±5% | 1.35 | |
| 85 | CL21C472JBFN NN □ | 4.7nF | 50 | ±5% | 1.35 | |
| 86 | CL21C562JBFN NN □ | 5.6nF | 50 | ±5% | 1.35 | |
| 87 | CL21C822JAFN NN □ | 8.2nF | 25 | ±5% | 1.35 | |
| 88 | CL21C103JBFN NN □ | 10nF | 50 | ±5% | 1.35 | |
| 1 | CL31C0R5CBCN NN □ | 3.20×1.60 | 0.5pF | 50 | ±0.25pF | 1.0 |
| 2 | CL31C010CBCN NN □ | | 1.0pF | 50 | ±0.25pF | 1.0 |
| 3 | CL31C1R5CBCN NN □ | | 1.5pF | 50 | ±0.25pF | 1.0 |
| 4 | CL31C1R8CBCN NN □ | | 1.8pF | 50 | ±0.25pF | 1.0 |
| 5 | CL31C020CBCN NN □ | | 2.0pF | 50 | ±0.25pF | 1.0 |
| 6 | CL31C2R2CBCN NN □ | | 2.2pF | 50 | ±0.25pF | 1.0 |
| 7 | CL31C2R7CBCN NN □ | | 2.7pF | 50 | ±0.25pF | 1.0 |

※ □ mark means packaging code. If you want to learn the code or quantity in detail, please see p80.

Part Numbering System

General Capacitors

High Capacitance Capacitors

Super Small Size Capacitors

Medium-High Voltage Capacitors

Array Type Capacitors

Low ESL Capacitors

Reliability Test Condition

Premium Capacitors for Automotive Applications

Packaging Specification

Application Manual for Surface Mounting

Product Lineup (General Capacitors-C0G)

| | Part Number | Size L × W (mm) | Capacitance | Rated Voltage (Vdc) | Capacitance Tolerance | Thickness Max. (mm) | |
|----|------------------|-----------------|-------------|---------------------|-----------------------|---------------------|------|
| 8 | CL31C030CBCNNN □ | 3.20×1.60 | 3.0pF | 50 | ±0.25pF | 1.0 | |
| 9 | CL31C3R3CBCNNN □ | | 3.3pF | 50 | ±0.25pF | 1.0 | |
| 10 | CL31C040CBCNNN □ | | 4.0pF | 50 | ±0.25pF | 1.0 | |
| 11 | CL31C4R7CBCNNN □ | | 4.7pF | 50 | ±0.25pF | 1.0 | |
| 12 | CL31C100JBCNNN □ | | 10pF | 50 | ±5% | 1.0 | |
| 13 | CL31C120JBCNNN □ | | 12pF | 50 | ±5% | 1.0 | |
| 14 | CL31C150JBCNNN □ | | 15pF | 50 | ±5% | 1.0 | |
| 15 | CL31C180JBCNNN □ | | 18pF | 50 | ±5% | 1.0 | |
| 16 | CL31C200JBCNNN □ | | 20pF | 50 | ±5% | 1.0 | |
| 17 | CL31C220JBCNNN □ | | 22pF | 50 | ±5% | 1.0 | |
| 18 | CL31C270JBCNNN □ | | 27pF | 50 | ±5% | 1.0 | |
| 19 | CL31C300JBCNNN □ | | 30pF | 50 | ±5% | 1.0 | |
| 20 | CL31C330JBCNNN □ | | 33pF | 50 | ±5% | 1.0 | |
| 21 | CL31C390JBCNNN □ | | 39pF | 50 | ±5% | 1.0 | |
| 22 | CL31C470JBCNNN □ | | 47pF | 50 | ±5% | 1.0 | |
| 23 | CL31C510JBCNNN □ | | 51pF | 50 | ±5% | 1.0 | |
| 24 | CL31C560JBCNNN □ | | 56pF | 50 | ±5% | 1.0 | |
| 25 | CL31C680JBCNNN □ | | 68pF | 50 | ±5% | 1.0 | |
| 26 | CL31C750JBCNNN □ | | 75pF | 50 | ±5% | 1.0 | |
| 27 | CL31C820JBCNNN □ | | 82pF | 50 | ±5% | 1.0 | |
| 28 | CL31C101JBCNNN □ | | 100pF | 50 | ±5% | 1.0 | |
| 29 | CL31C121JBCNNN □ | | 120pF | 50 | ±5% | 1.0 | |
| 30 | CL31C151JBCNNN □ | | 150pF | 50 | ±5% | 1.0 | |
| 31 | CL31C181JBCNNN □ | | 180pF | 50 | ±5% | 1.0 | |
| 32 | CL31C221JBCNNN □ | | 220pF | 50 | ±5% | 1.0 | |
| 33 | CL31C271JBCNNN □ | | 270pF | 50 | ±5% | 1.0 | |
| 34 | CL31C331JBCNNN □ | | 330pF | 50 | ±5% | 1.0 | |
| 35 | CL31C391JBCNNN □ | | 390pF | 50 | ±5% | 1.0 | |
| 36 | CL31C471JBCNNN □ | | 470pF | 50 | ±5% | 1.0 | |
| 37 | CL31C561JBCNNN □ | | 560pF | 50 | ±5% | 1.0 | |
| 38 | CL31C681JBCNNN □ | | 680pF | 50 | ±5% | 1.0 | |
| 39 | CL31C821JBCNNN □ | | 820pF | 50 | ±5% | 1.0 | |
| 40 | CL31C102JBCNNN □ | | 1nF | 50 | ±5% | 1.0 | |
| 41 | CL31C122JBCNNN □ | | 1.2nF | 50 | ±5% | 1.0 | |
| 42 | CL31C152JBCNNN □ | | 1.5nF | 50 | ±5% | 1.0 | |
| 43 | CL31C182JBCNNN □ | | 1.8nF | 50 | ±5% | 1.0 | |
| 44 | CL31C222JBCNNN □ | | 2.2nF | 50 | ±5% | 1.0 | |
| 45 | CL31C272JBFNNN □ | | 2.7nF | 50 | ±5% | 1.4 | |
| 46 | CL31C332JBFNNN □ | | 3.3nF | 50 | ±5% | 1.4 | |
| 47 | CL31C472JBFNNN □ | | 4.7nF | 50 | ±5% | 1.4 | |
| 48 | CL31C682JBHNNN □ | | 6.8nF | 50 | ±5% | 1.8 | |
| 49 | CL31C103JAFNNN □ | | 10nF | 25 | ±5% | 1.4 | |
| 50 | CL31C223JBHNNN □ | | 22nF | 50 | ±5% | 1.8 | |
| 51 | CL31C333JBHNNN □ | | 33nF | 50 | ±5% | 1.8 | |
| 1 | CL32C472JBFNNN □ | | 3.20×2.50 | 4.7nF | 50 | ±5% | 1.45 |
| 2 | CL32C103JBFNNN □ | | | 10nF | 50 | ±5% | 1.45 |
| 3 | CL32C223JBHNNN □ | | | 22nF | 50 | ±5% | 1.80 |

※ □mark means packaging code. If you want to learn the code or quantity in detail, please see p80.

Product Lineup (General Capacitors-X7R)

| | Part Number | Size L × W (mm) | Capacitance | Rated Voltage (Vdc) | Capacitance Tolerance | Thickness Max. (mm) |
|----|------------------|-----------------|-------------|---------------------|-----------------------|---------------------|
| 1 | CL05B471KB5NNN □ | 1.00×0.50 | 470pF | 50 | ±10% | 0.55 |
| 2 | CL05B221KB5NNN □ | | 220pF | 50 | ±10% | 0.55 |
| 3 | CL05B681KB5NNN □ | | 680pF | 50 | ±10% | 0.55 |
| 4 | CL05B102KB5NNN □ | | 1nF | 50 | ±10% | 0.55 |
| 5 | CL05B102KA5NNN □ | | 1nF | 25 | ±10% | 0.55 |
| 6 | CL05B222KB5NNN □ | | 2.2nF | 50 | ±10% | 0.55 |
| 7 | CL05B472KB5NNN □ | | 4.7nF | 50 | ±10% | 0.55 |
| 8 | CL05B472KA5NNN □ | | 4.7nF | 25 | ±10% | 0.55 |
| 9 | CL05B682KB5NNN □ | | 6.8nF | 50 | ±10% | 0.55 |
| 10 | CL05B682KA5NNN □ | | 6.8nF | 25 | ±10% | 0.55 |
| 11 | CL05B103KB5NNN □ | | 10nF | 50 | ±10% | 0.55 |
| 12 | CL05B103KA5NNN □ | | 10nF | 25 | ±10% | 0.55 |
| 13 | CL05B223KA5NNN □ | | 22nF | 25 | ±10% | 0.55 |
| 14 | CL05B473KO5NNN □ | | 47nF | 16 | ±10% | 0.55 |
| 15 | CL05B473KP5NNN □ | | 47nF | 10 | ±10% | 0.55 |
| 16 | CL05B683KO5NNN □ | | 68nF | 16 | ±10% | 0.55 |
| 17 | CL05B683KP5NNN □ | | 68nF | 10 | ±10% | 0.55 |
| 18 | CL05B104KO5NNN □ | | 100nF | 16 | ±10% | 0.55 |
| 19 | CL05B104KP5NNN □ | | 100nF | 10 | ±10% | 0.55 |
| 20 | CL05B104KQ5NNN □ | | 100nF | 6.3 | ±10% | 0.55 |
| 1 | CL10B101KB8NNN □ | 1.60×0.80 | 100pF | 50 | ±10% | 0.9 |
| 2 | CL10B221KB8NNN □ | | 220pF | 50 | ±10% | 0.9 |
| 3 | CL10B471KB8NNN □ | | 470pF | 50 | ±10% | 0.9 |
| 4 | CL10B681KB8NNN □ | | 680pF | 50 | ±10% | 0.9 |
| 5 | CL10B102KB8NNN □ | | 1nF | 50 | ±10% | 0.9 |
| 6 | CL10B102KA8NNN □ | | 1nF | 25 | ±10% | 0.9 |
| 7 | CL10B222KB8NNN □ | | 2.2nF | 50 | ±10% | 0.9 |
| 8 | CL10B472KB8NNN □ | | 4.7nF | 50 | ±10% | 0.9 |
| 9 | CL10B472KA8NNN □ | | 4.7nF | 25 | ±10% | 0.9 |
| 10 | CL10B682KB8NNN □ | | 6.8nF | 50 | ±10% | 0.9 |
| 11 | CL10B103KB8NNN □ | | 10nF | 50 | ±10% | 0.9 |
| 12 | CL10B103KA8NNN □ | | 10nF | 25 | ±10% | 0.9 |
| 13 | CL10B223KA8NNN □ | | 22nF | 25 | ±10% | 0.9 |
| 14 | CL10B473KB8NNN □ | | 47nF | 50 | ±10% | 0.9 |
| 15 | CL10B473KA8NNN □ | | 47nF | 25 | ±10% | 0.9 |
| 16 | CL10B683KB8NNN □ | | 68nF | 50 | ±10% | 0.9 |
| 17 | CL10B683KA8NNN □ | | 68nF | 25 | ±10% | 0.9 |
| 18 | CL10B104KB8NNN □ | | 100nF | 50 | ±10% | 0.9 |
| 19 | CL10B224KA8NNN □ | | 220nF | 25 | ±10% | 0.9 |
| 20 | CL10B224KO8NNN □ | | 220nF | 16 | ±10% | 0.9 |
| 21 | CL10B225KQ8NNN □ | | 2.2uF | 63 | ±10% | 0.9 |
| 1 | CL21B221KBANNN □ | 2.00×1.25 | 220pF | 50 | ±10% | 0.75 |
| 2 | CL21B471KBANNN □ | | 470pF | 50 | ±10% | 0.75 |
| 3 | CL21B681KBANNN □ | | 680pF | 50 | ±10% | 0.75 |
| 4 | CL21B102KBANNN □ | | 1nF | 50 | ±10% | 0.75 |
| 5 | CL21B102KBCNNN □ | | 1nF | 50 | ±10% | 0.95 |
| 6 | CL21B222KBANNN □ | | 2.2nF | 50 | ±10% | 0.75 |
| 7 | CL21B222KBCNNN □ | | 2.2nF | 50 | ±10% | 0.95 |
| 8 | CL21B682KBANNN □ | | 6.8nF | 50 | ±10% | 0.75 |
| 9 | CL21B103KBANNN □ | | 10nF | 50 | ±10% | 0.75 |

※ □mark means packaging code. If you want to learn the code or quantity in detail, please see p80.

※ For parts of higher capacitance than those above listed, refer to the product lineup of 'High Capacitance' subcategory.

Part Numbering System

General Capacitors

High Capacitance Capacitors

Super Small Size Capacitors

Medium-High Voltage Capacitors

Array Type Capacitors

Low ESL Capacitors

Reliability Test Condition

Premium Capacitors for Automotive Applications

Packaging Specification

Application Manual for Surface Mounting

Product Lineup (General Capacitors-X7R)

| | Part Number | Size L × W (mm) | Capacitance | Rated Voltage (Vdc) | Capacitance Tolerance | Thickness Max. (mm) | |
|----|------------------|-----------------|-------------|---------------------|-----------------------|---------------------|-----|
| 10 | CL21B103KBCNNN □ | 2.00×1.25 | 10nF | 50 | ±10% | 0.95 | |
| 11 | CL21B223KBANNN □ | | 22nF | 50 | ±10% | 0.75 | |
| 12 | CL21B223KBCNNN □ | | 22nF | 50 | ±10% | 0.95 | |
| 13 | CL21B473KBANNN □ | | 47nF | 50 | ±10% | 0.75 | |
| 14 | CL21B473KBCNNN □ | | 47nF | 50 | ±10% | 0.95 | |
| 15 | CL21B683KAANNN □ | | 68nF | 25 | ±10% | 0.75 | |
| 16 | CL21B683KBCNNN □ | | 68nF | 50 | ±10% | 0.95 | |
| 17 | CL21B683KBFNNN □ | | 68nF | 50 | ±10% | 1.35 | |
| 18 | CL21B104KBCNNN □ | | 100nF | 50 | ±10% | 0.95 | |
| 19 | CL21B104KBFNNN □ | | 100nF | 50 | ±10% | 1.35 | |
| 20 | CL21B224KBFNNN □ | | 220nF | 50 | ±10% | 1.35 | |
| 21 | CL21B224KAFNNN □ | | 220nF | 25 | ±10% | 1.35 | |
| 22 | CL21B224KOCNNN □ | | 220nF | 16 | ±10% | 0.95 | |
| 23 | CL21B224KOFNNN □ | | 220nF | 16 | ±10% | 1.35 | |
| 24 | CL21B474KBFNNN □ | | 470nF | 50 | ±10% | 1.35 | |
| 25 | CL21B474KAFNNN □ | | 470nF | 25 | ±10% | 1.35 | |
| 26 | CL21B474KOFNNN □ | | 470nF | 16 | ±10% | 1.35 | |
| 27 | CL21B684KOFNNN □ | | 680nF | 16 | ±10% | 1.35 | |
| 28 | CL21B684KPFNNN □ | | 680nF | 10 | ±10% | 1.35 | |
| 1 | CL31B221KBCNNN □ | | 3.20×1.60 | 220pF | 50 | ±10% | 1.0 |
| 2 | CL31B471KBCNNN □ | | | 470pF | 50 | ±10% | 1.0 |
| 3 | CL31B681KBCNNN □ | | | 680pF | 50 | ±10% | 1.0 |
| 4 | CL31B102KBCNNN □ | | | 1nF | 50 | ±10% | 1.0 |
| 5 | CL31B222KBCNNN □ | | | 2.2nF | 50 | ±10% | 1.0 |
| 6 | CL31B472KBCNNN □ | | | 4.7nF | 50 | ±10% | 1.0 |
| 7 | CL31B682KBCNNN □ | | | 6.8nF | 50 | ±10% | 1.0 |
| 8 | CL31B103KBCNNN □ | | | 10nF | 50 | ±10% | 1.0 |
| 9 | CL31B223KBCNNN □ | | | 22nF | 50 | ±10% | 1.0 |
| 10 | CL31B473KBCNNN □ | 47nF | | 50 | ±10% | 1.0 | |
| 11 | CL31B683KBCNNN □ | 68nF | | 50 | ±10% | 1.0 | |
| 12 | CL31B104KBCNNN □ | 100nF | | 50 | ±10% | 1.0 | |
| 13 | CL31B104KACNNN □ | 100nF | | 25 | ±10% | 1.0 | |
| 14 | CL31B224KBCNNN □ | 220nF | | 50 | ±10% | 1.0 | |
| 15 | CL31B224KAFNNN □ | 220nF | | 25 | ±10% | 1.4 | |
| 16 | CL31B474KBFNNN □ | 470nF | | 50 | ±10% | 1.4 | |
| 17 | CL31B474KAHNNN □ | 470nF | | 25 | ±10% | 1.8 | |
| 18 | CL31B474KOCNNN □ | 470nF | | 16 | ±10% | 1.0 | |
| 19 | CL31B684KBHNNN □ | 680nF | | 50 | ±10% | 1.8 | |
| 20 | CL31B684KAHNNN □ | 680nF | | 25 | ±10% | 1.8 | |
| 21 | CL31B105KBHNNN □ | 1μF | | 50 | ±10% | 1.8 | |
| 22 | CL31B105KAHNNN □ | 1μF | | 25 | ±10% | 1.8 | |
| 23 | CL31B105KOFNNN □ | 1μF | | 16 | ±10% | 1.4 | |
| 24 | CL31B225KBHNNN □ | 2.2μF | | 50 | ±10% | 1.8 | |
| 25 | CL31B225KAHNNN □ | 2.2μF | | 25 | ±10% | 1.8 | |
| 26 | CL31B225KOHNNN □ | 2.2μF | | 16 | ±10% | 1.8 | |
| 27 | CL31B225KPFNNN □ | 2.2μF | | 10 | ±10% | 1.4 | |
| 1 | CL32B104KBFNNN □ | 3.20×2.50 | 100nF | 50 | ±10% | 1.45 | |
| 2 | CL32B224KBFNNN □ | | 220nF | 50 | ±10% | 1.45 | |
| 3 | CL32B105KBFNNN □ | | 1μF | 50 | ±10% | 1.45 | |
| 4 | CL32B105KAHNNN □ | | 1μF | 25 | ±10% | 1.8 | |

※ □mark means packaging code. If you want to learn the code or quantity in detail, please see p80.

※ For parts of higher capacitance than those above listed, refer to the product lineup of 'High Capacitance' subcategory.

Product Lineup (General Capacitors-X7R)

| | Part Number | Size L × W (mm) | Capacitance | Rated Voltage (Vdc) | Capacitance Tolerance | Thickness Max. (mm) | |
|----|------------------|-----------------|-------------|---------------------|-----------------------|---------------------|------|
| 5 | CL32B104KBFNNN □ | 3.20×2.50 | 100nF | 50 | ±10% | 1.45 | |
| 6 | CL32B224KBFNNN □ | | 220nF | 50 | ±10% | 1.45 | |
| 7 | CL32B105KBFNNN □ | | 1μF | 50 | ±10% | 1.45 | |
| 8 | CL32B105KAHNNN □ | | 1μF | 25 | ±10% | 1.8 | |
| 9 | CL32B225KBINNN □ | | 2.2μF | 50 | ±10% | 2.2 | |
| 10 | CL32B225KAJNNN □ | | 2.2μF | 25 | ±10% | 2.7 | |
| 11 | CL32B474KBFNNN □ | | 470nF | 50 | ±10% | 1.45 | |
| 12 | CL32B474KAFNNN □ | | 470nF | 25 | ±10% | 1.45 | |
| 13 | CL32B475KONNNN □ | | 4.7μF | 16 | ±10% | 2.2 | |
| 1 | CL43B224KBFNNN □ | | 4.50×3.20 | 220nF | 50 | ±10% | 1.45 |
| 2 | CL43B474KBFNNN □ | | | 470nF | 50 | ±10% | 1.45 |
| 3 | CL43B684KBFNNN □ | | | 680nF | 50 | ±10% | 1.45 |
| 4 | CL43B105KBFNNN □ | | | 1μF | 50 | ±10% | 1.45 |
| 5 | CL43B106KALNNN □ | 10μF | | 25 | ±10% | 3.5 | |
| 6 | CL43B226KJNNN □ | 22μF | | 10 | ±10% | 2.7 | |
| 1 | CL55B475KBJNNN □ | 5.70×5.00 | 4.7μF | 50 | ±10% | 2.7 | |

Product Lineup (General Capacitors-X5R)

| | Part Number | Size L × W (mm) | Capacitance | Rated Voltage (Vdc) | Capacitance Tolerance | Thickness Max. (mm) |
|---|------------------|-----------------|-------------|---------------------|-----------------------|---------------------|
| 1 | CL05A223K05NNN □ | 1.00×0.50 | 22nF | 16 | ±10% | 0.55 |
| 2 | CL05A104KA5NNN □ | | 100nF | 25 | ±10% | 0.55 |
| 3 | CL05A104K05NNN □ | | 100nF | 16 | ±10% | 0.55 |
| 4 | CL05A104KP5NNN □ | | 100nF | 10 | ±10% | 0.55 |
| 5 | CL05A104KQ5NNN □ | | 100nF | 6.3 | ±10% | 0.55 |

※ □mark means packaging code. If you want to learn the code or quantity in detail, please see p80.

※ For parts of higher capacitance than those above listed, refer to the product lineup of 'High Capacitance' subcategory.

Part Numbering System

General Capacitors

High Capacitance Capacitors

Super Small Size Capacitors

Medium-High Voltage Capacitors

Array Type Capacitors

Low ESL Capacitors

Reliability Test Condition

Premium Capacitors for Automotive Applications

Packaging Specification

Application Manual for Surface Mounting

Product Lineup (General Capacitors-Y5V)

| | Part Number | Size L × W (mm) | Capacitance | Rated Voltage (Vdc) | Capacitance Tolerance | Thickness Max. (mm) |
|----|------------------|-----------------|-------------|---------------------|-----------------------|---------------------|
| 1 | CL05F103ZB5NNN □ | 1.0×0.5 | 10nF | 50 | +80%~-20% | 0.55 |
| 2 | CL05F103ZO5NNN □ | | 10nF | 16 | +80%~-20% | 0.55 |
| 3 | CL05F223ZA5NNN □ | | 22nF | 25 | +80%~-20% | 0.55 |
| 4 | CL05F223ZO5NNN □ | | 22nF | 16 | +80%~-20% | 0.55 |
| 5 | CL05F473ZO5NNN □ | | 47nF | 16 | +80%~-20% | 0.55 |
| 6 | CL05F683ZO5NNN □ | | 68nF | 16 | +80%~-20% | 0.55 |
| 7 | CL05F104ZO5NNN □ | | 100nF | 16 | +80%~-20% | 0.55 |
| 1 | CL10F103ZB8NNN □ | 1.6×0.8 | 10nF | 50 | +80%~-20% | 0.9 |
| 2 | CL10F223ZB8NNN □ | | 22nF | 50 | +80%~-20% | 0.9 |
| 3 | CL10F473ZB8NNN □ | | 47nF | 50 | +80%~-20% | 0.9 |
| 4 | CL10F473ZA8NNN □ | | 47nF | 25 | +80%~-20% | 0.9 |
| 5 | CL10F473ZO8NNN □ | | 47nF | 16 | +80%~-20% | 0.9 |
| 6 | CL10F683ZB8NNN □ | | 68nF | 50 | +80%~-20% | 0.9 |
| 7 | CL10F104ZB8NNN □ | | 100nF | 50 | +80%~-20% | 0.9 |
| 8 | CL10F104ZA8NNN □ | | 100nF | 25 | +80%~-20% | 0.9 |
| 9 | CL10F224ZB8NNN □ | | 220nF | 50 | +80%~-20% | 0.9 |
| 10 | CL10F224ZA8NNN □ | | 220nF | 25 | +80%~-20% | 0.9 |
| 11 | CL10F225ZP8NNN □ | | 2.2μF | 10 | +80%~-20% | 0.9 |
| 12 | CL10F225ZQ8NNN □ | | 2.2μF | 6.3 | +80%~-20% | 0.9 |
| 1 | CL21F103ZBANNN □ | 2.0×1.25 | 10nF | 50 | +80%~-20% | 0.75 |
| 2 | CL21F223ZBANNN □ | | 22nF | 50 | +80%~-20% | 0.75 |
| 3 | CL21F473ZBANNN □ | | 47nF | 50 | +80%~-20% | 0.75 |
| 4 | CL21F683ZBANNN □ | | 68nF | 50 | +80%~-20% | 0.75 |
| 5 | CL21F104ZBANNN □ | | 100nF | 50 | +80%~-20% | 0.75 |
| 6 | CL21F104ZBCNNN □ | | 100nF | 50 | +80%~-20% | 0.95 |
| 7 | CL21F224ZBCNNN □ | | 220nF | 50 | +80%~-20% | 0.95 |
| 8 | CL21F224ZBFNNN □ | | 220nF | 50 | +80%~-20% | 1.35 |
| 9 | CL21F224ZOANNN □ | | 220nF | 16 | +80%~-20% | 0.75 |
| 10 | CL21F474ZACNNN □ | | 470nF | 25 | +80%~-20% | 0.95 |
| 11 | CL21F474ZBFNNN □ | | 470nF | 50 | +80%~-20% | 1.35 |
| 12 | CL21F474ZBFNNN □ | | 470nF | 50 | +80%~-20% | 1.35 |
| 13 | CL21F684ZAFNNN □ | | 680nF | 25 | +80%~-20% | 1.35 |
| 14 | CL21F684ZOANNN □ | | 680nF | 16 | +80%~-20% | 0.75 |
| 15 | CL21F225ZAFNNN □ | | 2.2μF | 25 | +80%~-20% | 1.35 |
| 16 | CL21F225ZOFNNN □ | | 2.2μF | 16 | +80%~-20% | 1.35 |
| 1 | CL31F103ZBCNNN □ | 3.2×1.6 | 10nF | 50 | +80%~-20% | 1.0 |
| 2 | CL31F104ZBCNNN □ | | 100nF | 50 | +80%~-20% | 1.0 |
| 3 | CL31F224ZBCNNN □ | | 220nF | 50 | +80%~-20% | 1.0 |
| 4 | CL31F474ZBCNNN □ | | 470nF | 50 | +80%~-20% | 1.0 |
| 5 | CL31F105ZBCNNN □ | | 1μF | 50 | +80%~-20% | 1.0 |
| 6 | CL31F105ZAFNNN □ | | 1μF | 25 | +80%~-20% | 1.4 |
| 7 | CL31F105ZOCNNN □ | | 1μF | 16 | +80%~-20% | 1.0 |
| 8 | CL31F225ZAFNNN □ | | 2.2μF | 25 | +80%~-20% | 1.4 |
| 9 | CL31F225ZOCNNN □ | | 2.2μF | 16 | +80%~-20% | 1.0 |
| 1 | CL32F475ZAHNNN □ | 3.2×2.5 | 4.7μF | 25 | +80%~-20% | 1.8 |
| 1 | CL43A476MQJNNN □ | 4.5×3.2 | 10μF | 6.3 | +80%~-20% | 2.7 |
| 2 | CL43A107MQLNNN □ | | 100μF | 6.3 | +80%~-20% | 3.5 |

※ □ mark means packaging code. If you want to learn the code or quantity in detail, please see p80.

※ For parts of higher capacitance than those above listed, refer to the product lineup of 'High Capacitance' subcategory.

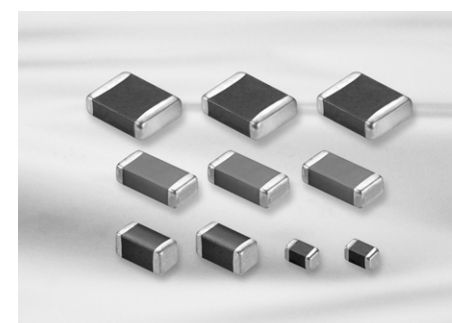

Feature

- Wide selection of size : from 0402 to 1812
- Highly reliable tolerance and high speed automatic chip placement on PCBs
- Wide capacitance range
- Highly reliable performance
- Highly resistant termination metal
- Tape & reel for surface mount assembly

Application

- Desktop PC, Note PC, HHP, DC-DC Converter, DSC
- LCD TV, LCD Monitor
- ※ For using special purpose like Military, Medical, Aviation, Automobile device should be following a special specification.

Structure and Dimensions

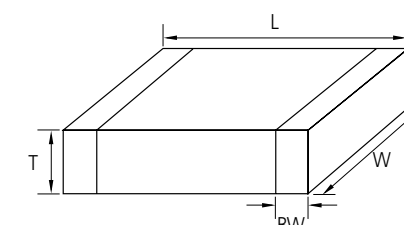

| Size Code | EIA Code | Dimension(mm) | | | | |
|-----------|----------|---------------|-----------|-----------|----------------|---------------|
| | | L | W | T | Thickness Code | BW |
| 05 | 0402 | 1.00±0.05 | 0.50±0.05 | 0.50±0.05 | 5 | 0.2+0.15/-0.1 |
| 10 | 0603 | 1.60±0.10 | 0.80±0.10 | 0.50±0.05 | 5 | 0.30±0.20 |
| | | | | 0.80±0.10 | 8 | |
| 21 | 0805 | 2.00±0.10 | 1.25±0.10 | 0.85±0.10 | C | 0.5+0.2/-0.3 |
| | | | | 1.25±0.10 | F | |
| | | | | 2.00±0.15 | 1.25±0.15 | |
| 31 | 1206 | 3.20±0.20 | 1.60±0.20 | 0.60±0.10 | 6 | 0.50+0.30 |
| | | | | 0.85±0.10 | C | |
| | | | | 1.15±0.10 | P | |
| 32 | 1210 | 3.20±0.30 | 2.50±0.20 | 0.85±0.10 | C | 0.60±0.30 |
| | | | | 0.90±0.10 | 9 | |
| | | | | 1.60±0.20 | H | |
| 42 | 1808 | 4.50±0.40 | 2.00±0.20 | 1.80±0.20 | U | 0.80±0.30 |
| | | | | 2.00±0.20 | I | |
| | | | | 2.50±0.20 | J | |
| 43 | 1812 | 4.50±0.40 | 3.20±0.30 | 2.50±0.30 | v | 0.80±0.30 |

Part Numbering System

General Capacitors

High Capacitance Capacitors

Super Small Size Capacitors

Medium-High Voltage Capacitors

Array Type Capacitors

Low ESL Capacitors

Reliability Test Condition

Premium Capacitors for Automotive Applications

Packaging Specification

Application Manual for Surface Mounting

High Capacitance Table (X5R)

| Size(mm) | Vr(V) | Capacitance (uF) | | | | | | | | | | |
|------------|------------|------------------|------|------|---|-----|-----|----|----|----|-----|--|
| | | 0.1 | 0.22 | 0.47 | 1 | 2.2 | 4.7 | 10 | 22 | 47 | 100 | |
| 0402(1005) | 4 | | | | | | | | | | | |
| | 6.3 | | | | | | | | | | | |
| | 10 | | | | | | | | | | | |
| | 16 | | | | | | | | | | | |
| | 25 | | | | | | | | | | | |
| 0603(1608) | 4 | | | | | | | | | | | |
| | 6.3 | | | | | | | | | | | |
| | 10 | | | | | | | | | | | |
| | 16 | | | | | | | | | | | |
| | 25 | | | | | | | | | | | |
| | 50 | | | | | | | | | | | |
| 0805(2012) | 4 | | | | | | | | | | | |
| | 6.3 | | | | | | | | | | | |
| | 10 | | | | | | | | | | | |
| | 16 | | | | | | | | | | | |
| | 25 | | | | | | | | | | | |
| | 50 | | | | | | | | | | | |
| 1206(3216) | 6.3 | | | | | | | | | | | |
| | 10 | | | | | | | | | | | |
| | 16 | | | | | | | | | | | |
| | 25 | | | | | | | | | | | |
| | 50 | | | | | | | | | | | |
| | 1210(3225) | 6.3 | | | | | | | | | | |
| 10 | | | | | | | | | | | | |
| 16 | | | | | | | | | | | | |
| 25 | | | | | | | | | | | | |

High Capacitance Table_Low Profile (X5R)

| Size(mm) | Tmax (mm) | Vr(V) | Capacitance (uF) | | | | | | | | | |
|------------|-----------|-------|------------------|-----|-----|----|----|----|----|--|------------|--|
| | | | 1 | 2.2 | 4.7 | 10 | 22 | 33 | 47 | | | |
| 0402(1005) | 0.3 | 6.3 | X6S | | | | | | | | | |
| | | 10 | | | | | | | | | | |
| | | 16 | | | | | | | | | | |
| 0603(1608) | 0.5 | 6.3 | | | | | | | | | | |
| | | 10 | | | | | | | | | | |
| | | 16 | | | | | | | | | | |
| | | 25 | | | | | | | | | | |
| 0805(2012) | 0.5 | 10 | | | | | | | | | | |
| | | 16 | | | | | | | | | | |
| | | 25 | | | | | | | | | | |
| | 0.95 | 4 | | | | | | | | | (Tmax=1.0) | |
| | | 6.3 | | | | | | | | | (Tmax=1.0) | |
| | | 10 | | | | | | | | | | |
| 1206(3216) | 0.95 | 16 | | | | | | | | | | |
| | | 25 | | | | | | | | | | |
| | | 50 | | | | | | | | | | |
| | | 0.7 | 10 | | | | | | | | | |
| | | | 6.3 | | | | | | | | | |
| 1210(3225) | 2.0 | 16 | | | | | | | | | | |
| | | 25 | | | | | | | | | | |
| | | 35 | | | | | | | | | | |
| | | 50 | | | | | | | | | | |

Part Numbering System

General Capacitors

High Capacitance Capacitors

Super Small Size Capacitors

Medium-High Voltage Capacitors

Array Type Capacitors

Low ESL Capacitors

Reliability Test Condition

Premium Capacitors for Automotive Applications

Packaging Specification

Application Manual for Surface Mounting

High Capacitance Table (X6S)

| Size(mm) | Vr(V) | Capacitance (uF) | | | | | | | | | | |
|------------|-------|------------------|------|------|---|-----|-----|----|----|----|-----|--|
| | | 0.1 | 0.22 | 0.47 | 1 | 2.2 | 4.7 | 10 | 22 | 47 | 100 | |
| 0402(1005) | 4 | | | | | | | | | | | |
| | 6.3 | | | | | | | | | | | |
| | 10 | | | | | | | | | | | |
| 0603(1608) | 4 | | | | | | | | | | | |
| | 6.3 | | | | | | | | | | | |
| | 10 | | | | | | | | | | | |
| | 16 | | | | | | | | | | | |
| | 25 | | | | | | | | | | | |
| 0805(2012) | 4 | | | | | | | | | | | |
| | 6.3 | | | | | | | | | | | |
| | 10 | | | | | | | | | | | |
| | 16 | | | | | | | | | | | |
| | 25 | | | | | | | | | | | |
| 1206(3216) | 6.3 | | | | | | | | | | | |
| | 10 | | | | | | | | | | | |
| | 16 | | | | | | | | | | | |
| | 25 | | | | | | | | | | | |
| 1210(3225) | 6.3 | | | | | | | | | | | |
| | 10 | | | | | | | | | | | |
| | 16 | | | | | | | | | | | |
| | 25 | | | | | | | | | | | |

High Capacitance Table (X7R)

| Size(mm) | Vr(V) | Capacitance (uF) | | | | | | | | | | |
|------------|-------|------------------|------|------|---|-----|-----|----|----|----|-----|--|
| | | 0.1 | 0.22 | 0.47 | 1 | 2.2 | 4.7 | 10 | 22 | 47 | 100 | |
| 0402(1005) | 6.3 | | | | | | | | | | | |
| | 10 | | | | | | | | | | | |
| | 16 | | | | | | | | | | | |
| 0603(1608) | 6.3 | | | | | | | | | | | |
| | 10 | | | | | | | | | | | |
| | 16 | | | | | | | | | | | |
| | 25 | | | | | | | | | | | |
| | 50 | | | | | | | | | | | |
| 0805(2012) | 6.3 | | | | | | | | | | | |
| | 10 | | | | | | | | | | | |
| | 16 | | | | | | | | | | | |
| | 25 | | | | | | | | | | | |
| | 35 | | | | | | | | | | | |
| | 50 | | | | | | | | | | | |
| 1206(3216) | 6.3 | | | | | | | | | | | |
| | 10 | | | | | | | | | | | |
| | 16 | | | | | | | | | | | |
| | 25 | | | | | | | | | | | |
| | 35 | | | | | | | | | | | |
| 1210(3225) | 6.3 | | | | | | | | | | | |
| | 10 | | | | | | | | | | | |
| | 16 | | | | | | | | | | | |
| | 25 | | | | | | | | | | | |
| | 50 | | | | | | | | | | | |

Part Numbering System

General Capacitors

High Capacitance Capacitors

Super Small Size Capacitors

Medium-High Voltage Capacitors

Array Type Capacitors

Low ESL Capacitors

Reliability Test Condition

Premium Capacitors for Automotive Applications

Packaging Specification

Application Manual for Surface Mounting

High Capacitance Table (Y5V)

| Size(mm) | Vr(V) | Capacitance (uF) | | | | | | | | | |
|------------|-------|------------------|------|------|---|-----|-----|----|----|------------|------------|
| | | 0.1 | 0.22 | 0.47 | 1 | 2.2 | 4.7 | 10 | 22 | 47 | |
| 0402(1005) | 6.3 | | | | | | | | | | |
| | 10 | | | | | | | | | | |
| | 16 | | | | | | | | | | |
| | 6.3 | | | | | | | | | | |
| 0603(1608) | 6.3 | | | | | | | | | | |
| | 10 | | | | | | | | | | |
| | 16 | | | | | | | | | | |
| | 25 | | | | | | | | | | |
| | 50 | | | | | | | | | | |
| 0805(2012) | 6.3 | | | | | | | | | | |
| | 10 | | | | | | | | | | |
| | 16 | | | | | | | | | | |
| | 25 | | | | | | | | | | |
| | 50 | | | | | | | | | | |
| 1206(3216) | 6.3 | | | | | | | | | | |
| | 10 | | | | | | | | | | |
| | 16 | | | | | | | | | | |
| | 25 | | | | | | | | | | |
| | 50 | | | | | | | | | | |
| 1210(3225) | 6.3 | | | | | | | | | | |
| | 10 | | | | | | | | | (Tmax=2.7) | (Tmax=2.0) |
| | 16 | | | | | | | | | (Tmax=1.2) | |
| | 25 | | | | | | | | | (Tmax=1.8) | (Tmax=1.5) |
| | 35 | | | | | | | | | (Tmax=1.4) | (Tmax=1.6) |
| | 50 | | | | | | | | | | |

Product Lineup (High Capacitance-X5R)

| | Part Number | Size L×W (mm) | Capacitance | Rated Voltage (Vdc) | Capacitance Tolerance | Thickness Max. (mm) |
|----|------------------|---------------|-------------|---------------------|-----------------------|---------------------|
| 1 | CL05A224KQ5NNN □ | 100×0.50 | 0.22μF | 6.3 | ±10% | 0.55 |
| 2 | CL05A224KR5NNN □ | | 0.22μF | 4 | ±10% | 0.55 |
| 3 | CL05A224KA5NNN □ | | 0.22μF | 25 | ±10% | 0.55 |
| 4 | CL05A224KQ5NNN □ | | 0.22μF | 16 | ±10% | 0.55 |
| 5 | CL05A224KP5NNN □ | | 0.22μF | 10 | ±10% | 0.55 |
| 6 | CL05A334KA5NNN □ | | 0.33μF | 25 | ±10% | 0.55 |
| 7 | CL05A334KQ5NNN □ | | 0.33μF | 6.3 | ±10% | 0.55 |
| 8 | CL05A334KR5NNN □ | | 0.33μF | 4 | ±10% | 0.55 |
| 9 | CL05A474KA5NNN □ | | 0.47μF | 25 | ±10% | 0.55 |
| 10 | CL05A474KQ5NNN □ | | 0.47μF | 16 | ±10% | 0.55 |
| 11 | CL05A474KP5NNN □ | | 0.47μF | 10 | ±10% | 0.55 |
| 12 | CL05A474KQ5NNN □ | | 0.47μF | 6.3 | ±10% | 0.55 |
| 13 | CL05A474KR5NNN □ | | 0.47μF | 4 | ±10% | 0.55 |
| 14 | CL05A105KA5NQ □ | | 1μF | 25 | ±10% | 0.60 |
| 15 | CL05A105KQ5NNN □ | | 1μF | 16 | ±10% | 0.55 |
| 16 | CL05A105KQ3LQN □ | | 1μF | 16 | ±10% | 0.33 |
| 17 | CL05A105KP5NNN □ | | 1μF | 10 | ±10% | 0.55 |
| 18 | CL05A105KP3LNN □ | | 1μF | 10 | ±10% | 0.33 |
| 19 | CL05A105KQ5NNN □ | | 1μF | 6.3 | ±10% | 0.55 |
| 20 | CL05A105KQ3LNN □ | | 1μF | 6.3 | ±10% | 0.33 |
| 21 | CL05A105KR5NNN □ | | 1μF | 4 | ±10% | 0.55 |
| 22 | CL05A105KR3LNN □ | | 1μF | 4 | ±10% | 0.33 |
| 23 | CL05A225KQ5NQ □ | | 2.2μF | 16 | ±10% | 0.60 |
| 24 | CL05A225MP5NS □ | | 2.2μF | 10 | ±20% | 0.57 |
| 25 | CL05A225KP3LRN □ | | 2.2μF | 10 | ±10% | 0.33 |
| 26 | CL05A225MQ5NNN □ | | 2.2μF | 6.3 | ±20% | 0.55 |
| 27 | CL05A225KQ3LRN □ | | 2.2μF | 6.3 | ±10% | 0.33 |
| 28 | CL05A225MR5NNN □ | | 2.2μF | 4 | ±20% | 0.55 |
| 29 | CL05A225KR3LRN □ | | 2.2μF | 4 | ±10% | 0.33 |
| 30 | CL05A475MP5NRR □ | | 4.7μF | 10 | ±20% | 0.65 |
| 31 | CL05A475MQ5NRR □ | | 4.7μF | 6.3 | ±20% | 0.65 |
| 32 | CL05A475MR5NRR □ | | 4.7μF | 4 | ±20% | 0.65 |
| 33 | CL05A106MQ5NUN □ | | 10μF | 6.3 | ±20% | 0.70 |
| 34 | CL05A106MR5NRR □ | | 10μF | 4 | ±20% | 0.65 |
| 1 | CL10A474KB8NNN □ | 1.60×0.80 | 0.47μF | 50 | ±10% | 0.90 |
| 2 | CL10A474KA8NNN □ | | 0.47μF | 25 | ±10% | 0.90 |
| 3 | CL10A474KP8NNN □ | | 0.47μF | 10 | ±10% | 0.90 |
| 4 | CL10A474KQ8NNN □ | | 0.47μF | 6.3 | ±10% | 0.90 |
| 5 | CL10A474KR8NNN □ | | 0.47μF | 4 | ±10% | 0.90 |
| 6 | CL10A105KB8NNN □ | | 1μF | 50 | ±10% | 0.90 |
| 7 | CL10A105KA85NN □ | | 1μF | 25 | ±10% | 0.55 |
| 8 | CL10A105KA8NNN □ | | 1μF | 25 | ±10% | 0.90 |
| 9 | CL10A105KQ8NNN □ | | 1μF | 16 | ±10% | 0.90 |
| 10 | CL10A105KQ5LNN □ | | 1μF | 16 | ±10% | 0.55 |
| 11 | CL10A105KP8NNN □ | | 1μF | 10 | ±10% | 0.90 |
| 12 | CL10A105KP5LNN □ | | 1μF | 10 | ±10% | 0.55 |
| 13 | CL10A105KQ8NNN □ | | 1μF | 6.3 | ±10% | 0.90 |
| 14 | CL10A105KQ5LNN □ | | 1μF | 6.3 | ±10% | 0.55 |

※ □ mark means packaging code. If you want to learn the code or quantity in detail, please see p80.

- Part Numbering System
- General Capacitors
- High Capacitance Capacitors
- Super Small Size Capacitors
- Medium-High Voltage Capacitors
- Array Type Capacitors
- Low ESL Capacitors
- Reliability Test Condition
- Premium Capacitors for Automotive Applications
- Packaging Specification
- Application Manual for Surface Mounting

Product Lineup (High Capacitance-X5R)

| | Part Number | Size L × W (mm) | Capacitance | Rated Voltage (Vdc) | Capacitance Tolerance | Thickness Max. (mm) | |
|----|------------------|-----------------|-------------|---------------------|-----------------------|---------------------|------|
| 15 | CL10A105KR8NNN □ | 1.60×0.80 | 1 μF | 4 | ±10% | 0.90 | |
| 16 | CL10A105KR5LNN □ | | 1 μF | 4 | ±10% | 0.55 | |
| 17 | CL10A225KA8NNN □ | | 2.2 μF | 25 | ±10% | 0.90 | |
| 18 | CL10A105KA85NN □ | | 2.2 μF | 25 | ±10% | 0.55 | |
| 19 | CL10A225KO8NNN □ | | 2.2 μF | 16 | ±10% | 0.90 | |
| 20 | CL10A225KO5LNN □ | | 2.2 μF | 16 | ±10% | 0.55 | |
| 21 | CL10A225KP8NNN □ | | 2.2 μF | 10 | ±10% | 0.90 | |
| 22 | CL10A225KP5LNN □ | | 2.2 μF | 10 | ±10% | 0.55 | |
| 23 | CL10A225KQ8NNN □ | | 2.2 μF | 6.3 | ±10% | 0.90 | |
| 24 | CL10A225KQ5LNN □ | | 2.2 μF | 6.3 | ±10% | 0.55 | |
| 25 | CL10A225KR8NNN □ | | 2.2 μF | 4 | ±10% | 0.90 | |
| 26 | CL10A225KR5LNN □ | | 2.2 μF | 4 | ±10% | 0.55 | |
| 27 | CL10A335KQ8NNN □ | | 3.3 μF | 6.3 | ±10% | 0.90 | |
| 28 | CL10A335KR8NNN □ | | 3.3 μF | 4 | ±10% | 0.90 | |
| 29 | CL10A475KA8NQ □ | | 4.7 μF | 25 | ±10% | 0.95 | |
| 30 | CL10A475KO8NNN □ | | 4.7 μF | 16 | ±10% | 0.90 | |
| 31 | CL10A475KP8NNN □ | | 4.7 μF | 10 | ±10% | 0.90 | |
| 32 | CL10A475KP5NNN □ | | 4.7 μF | 10 | ±10% | 0.55 | |
| 33 | CL10A475KQ5LNN □ | | 4.7 μF | 6.3 | ±10% | 0.55 | |
| 34 | CL10A475KQ8NNN □ | | 4.7 μF | 6.3 | ±10% | 0.90 | |
| 35 | CL10A475KR5LNN □ | | 4.7 μF | 4 | ±10% | 0.55 | |
| 36 | CL10A475KR8NNN □ | | 4.7 μF | 4 | ±10% | 0.90 | |
| 37 | CL10A106MO8NQ □ | | 10 μF | 16 | ±20% | 0.95 | |
| 38 | CL10A106MP8NNN □ | | 10 μF | 10 | ±20% | 0.90 | |
| 39 | CL10A106KQ8NNN □ | | 10 μF | 6.3 | ±10% | 0.90 | |
| 40 | CL10A106MQ5NRR □ | | 10 μF | 6.3 | ±10% | 0.55 | |
| 41 | CL10A106KR8NNN □ | | 10 μF | 4 | ±10% | 0.90 | |
| 42 | CL10A106MR5NRR □ | | 10 μF | 4 | ±10% | 0.55 | |
| 43 | CL10A226MQ8NRR □ | | 22 μF | 6.3 | ±20% | 1.00 | |
| 44 | CL10A226MR8NRR □ | | 22 μF | 4 | ±20% | 1.00 | |
| 1 | CL21A105KBQNNN □ | | 2.00×1.25 | 1 μF | 50 | ±10% | 1.40 |
| 2 | CL21A105KAFNNN □ | | | 1 μF | 25 | ±10% | 1.35 |
| 3 | CL21A105KA6LNN □ | | | 1 μF | 25 | ±10% | 0.70 |
| 4 | CL21A105KOFNNN □ | | | 1 μF | 16 | ±10% | 1.35 |
| 5 | CL21A105KO6LNN □ | | | 1 μF | 16 | ±10% | 0.70 |
| 6 | CL21A105KQFNNN □ | | | 1 μF | 6.3 | ±10% | 1.35 |
| 7 | CL21A105KRFNNN □ | | | 1 μF | 4 | ±10% | 1.35 |
| 8 | CL21A225KBQNNN □ | | | 2.2 μF | 50 | ±10% | 1.40 |
| 9 | CL21A225KAFNNN □ | | | 2.2 μF | 25 | ±10% | 1.35 |
| 10 | CL21A225KO6LNN □ | | | 2.2 μF | 16 | ±10% | 0.70 |
| 11 | CL21A225KOFNNN □ | | | 2.2 μF | 16 | ±10% | 1.35 |
| 12 | CL21A225KPFNNN □ | | | 2.2 μF | 10 | ±10% | 1.35 |
| 13 | CL21A225KQFNNN □ | | | 2.2 μF | 6.3 | ±10% | 1.35 |
| 14 | CL21A225KRFNNN □ | | | 2.2 μF | 4 | ±10% | 1.35 |
| 15 | CL21A475KBQNNN □ | 4.7 μF | | 50 | ±10% | 1.40 | |
| 16 | CL21A475KAQNNN □ | 4.7 μF | | 25 | ±10% | 1.40 | |
| 17 | CL21A475KAQLRN □ | 4.7 μF | | 25 | ±10% | 0.95 | |
| 18 | CL21A475KOFNNN □ | 4.7 μF | | 16 | ±10% | 1.35 | |
| 19 | CL21A475KOCLNN □ | 4.7 μF | | 16 | ±10% | 0.70 | |
| 20 | CL21A475KPFNNN □ | 4.7 μF | | 10 | ±10% | 1.35 | |

※ □mark means packaging code. If you want to learn the code or quantity in detail, please see p 80.

Product Lineup (High Capacitance-X5R)

| | Part Number | Size L × W (mm) | Capacitance | Rated Voltage (Vdc) | Capacitance Tolerance | Thickness Max. (mm) | |
|----|------------------|-----------------|-------------|---------------------|-----------------------|---------------------|------|
| 21 | CL21A475KPCLNN □ | 2.00×1.25 | 4.7 μF | 10 | ±10% | 0.95 | |
| 22 | CL21A475KQFNNN □ | | 4.7 μF | 6.3 | ±10% | 1.35 | |
| 23 | CL21A475KQCLNN □ | | 4.7 μF | 6.3 | ±10% | 0.95 | |
| 24 | CL21A475KRFNNN □ | | 4.7 μF | 4 | ±10% | 1.35 | |
| 25 | CL21A106KAYNNN □ | | 10 μF | 25 | ±10% | 1.45 | |
| 26 | CL21A106KACLNN □ | | 10 μF | 25 | ±10% | 0.95 | |
| 27 | CL21A106KOFNNN □ | | 10 μF | 16 | ±10% | 1.35 | |
| 28 | CL21A106KQNNN □ | | 10 μF | 16 | ±10% | 1.40 | |
| 29 | CL21A106KOCLRN □ | | 10 μF | 16 | ±10% | 0.70 | |
| 30 | CL21A106KPFNNN □ | | 10 μF | 10 | ±10% | 1.35 | |
| 31 | CL21A106KPCLQN □ | | 10 μF | 10 | ±20% | 0.95 | |
| 32 | CL21A106KQFNNN □ | | 10 μF | 6.3 | ±10% | 1.35 | |
| 33 | CL21A106KQCLNN □ | | 10 μF | 6.3 | ±10% | 0.95 | |
| 34 | CL21A475KRCLNN □ | | 4.7 μF | 4 | ±10% | 0.95 | |
| 35 | CL21A106KRFNNN □ | | 10 μF | 4 | ±10% | 1.35 | |
| 36 | CL21A106KRCLNN □ | | 10 μF | 4 | ±10% | 0.95 | |
| 37 | CL21A226MPQNNN □ | | 22 μF | 10 | ±20% | 1.40 | |
| 38 | CL21A226MPCLRN □ | | 22 μF | 10 | ±20% | 0.95 | |
| 39 | CL21A226MQNNN □ | | 22 μF | 6.3 | ±20% | 1.40 | |
| 40 | CL21A226MQCLRN □ | | 22 μF | 6.3 | ±20% | 0.95 | |
| 41 | CL21A226MRQNNN □ | | 22 μF | 4 | ±20% | 1.40 | |
| 42 | CL21A226MRCLRN □ | | 22 μF | 4 | ±20% | 0.95 | |
| 43 | CL21A336MQELNN □ | | 33 μF | 6.3 | ±20% | 1.20 | |
| 44 | CL21A336MQ9LNN □ | | 33 μF | 6.3 | ±20% | 1.00 | |
| 45 | CL21A336MRELNN □ | | 33 μF | 4 | ±20% | 1.20 | |
| 46 | CL21A336MR9LNN □ | | 33 μF | 4 | ±20% | 1.00 | |
| 47 | CL21A476MQYNNN □ | | 47 μF | 6.3 | ±20% | 1.45 | |
| 48 | CL21A476MRYNNN □ | | 47 μF | 4.0 | ±20% | 1.45 | |
| 1 | CL31A475KBHNNN □ | | 3.20×1.60 | 4.7 μF | 50 | ±10% | 1.80 |
| 2 | CL31A475KB9LNN □ | | | 4.7 μF | 50 | ±10% | 1.00 |
| 3 | CL31A475KAHNNN □ | | | 4.7 μF | 25 | ±10% | 1.80 |
| 4 | CL31A475KAQLNN □ | | | 4.7 μF | 25 | ±10% | 0.95 |
| 5 | CL31A475KOHNNN □ | | | 4.7 μF | 16 | ±10% | 1.80 |
| 6 | CL31A475KOCLNN □ | | | 4.7 μF | 16 | ±10% | 0.95 |
| 7 | CL31A475KPHNNN □ | | | 4.7 μF | 10 | ±10% | 1.80 |
| 8 | CL31A475KQHNNN □ | | | 4.7 μF | 6.3 | ±10% | 1.80 |
| 9 | CL31A475KRHNNN □ | | | 4.7 μF | 4 | ±10% | 1.80 |
| 10 | CL31A106KBHNNN □ | | | 10 μF | 50 | ±10% | 1.80 |
| 11 | CL31A106KAHNNN □ | | | 10 μF | 25 | ±10% | 1.80 |
| 12 | CL31A106KAQLNN □ | | | 10 μF | 25 | ±10% | 0.95 |
| 13 | CL31A106KOHNNN □ | | | 10 μF | 16 | ±10% | 1.80 |
| 14 | CL31A106KOCLNN □ | | | 10 μF | 16 | ±10% | 0.95 |
| 15 | CL31A106KPHNNN □ | | | 10 μF | 10 | ±10% | 1.80 |
| 16 | CL31A106KPCLNN □ | | | 10 μF | 10 | ±10% | 0.95 |
| 17 | CL31A106KQHNNN □ | | | 10 μF | 6.3 | ±10% | 1.80 |
| 18 | CL31A106KRHNNN □ | | | 10 μF | 4 | ±10% | 1.80 |
| 19 | CL31A156KQHNNN □ | | | 15 μF | 6.3 | ±10% | 1.80 |
| 20 | CL31A156KRHNNN □ | | | 15 μF | 4 | ±10% | 1.80 |
| 21 | CL31A226KAHNNN □ | 22 μF | | 25 | ±10% | 1.80 | |
| 22 | CL31A226KOHNNN □ | 22 μF | | 16 | ±10% | 1.80 | |

※ □mark means packaging code. If you want to learn the code or quantity in detail, please see p 80.

- Part Numbering System
- General Capacitors
- High Capacitance Capacitors
- Super Small Size Capacitors
- Medium-High Voltage Capacitors
- Array Type Capacitors
- Low ESL Capacitors
- Reliability Test Condition
- Premium Capacitors for Automotive Applications
- Packaging Specification
- Application Manual for Surface Mounting

Product Lineup (High Capacitance-X5R)

| | Part Number | Size L × W (mm) | Capacitance | Rated Voltage (Vdc) | Capacitance Tolerance | Thickness Max. (mm) |
|----|-------------------|-----------------|-------------|---------------------|-----------------------|---------------------|
| 23 | CL31A226KOCCLNN □ | 3.20 × 1.60 | 22 μ F | 16 | ±10% | 0.95 |
| 24 | CL31A226KPHNNN □ | | 22 μ F | 10 | ±10% | 1.80 |
| 25 | CL31A226KPCCLNN □ | | 22 μ F | 10 | ±10% | 0.95 |
| 26 | CL31A226KQHNNN □ | | 22 μ F | 6.3 | ±10% | 1.80 |
| 27 | CL31A226KRHNNN □ | | 22 μ F | 4.0 | ±10% | 1.80 |
| 28 | CL31A476MQHNNN □ | | 47 μ F | 6.3 | ±20% | 1.80 |
| 29 | CL31A476MRHNNN □ | | 47 μ F | 4.0 | ±20% | 1.80 |
| 30 | CL31A107MQHNNN □ | | 100 μ F | 6.3 | ±20% | 1.80 |
| 31 | CL31A107MRHNNN □ | | 100 μ F | 4.0 | ±20% | 1.80 |
| 1 | CL32A106KQCLNN □ | | 3.20 × 2.50 | 10 μ F | 6.3 | ±10% |
| 2 | CL32A106KRCLNN □ | 10 μ F | | 4.0 | ±10% | 0.95 |
| 3 | CL32A106KBULNN □ | 10 μ F | | 50 | ±10% | 2.00 |
| 4 | CL32A106KAJNNN □ | 10 μ F | | 25 | ±10% | 2.70 |
| 5 | CL32A106KAULNN □ | 10 μ F | | 25 | ±10% | 2.00 |
| 6 | CL32A106KOJNNN □ | 10 μ F | | 16 | ±10% | 2.70 |
| 7 | CL32A106KPJNNN □ | 10 μ F | | 10 | ±10% | 2.70 |
| 8 | CL32A226KAJNNN □ | 22 μ F | | 25 | ±10% | 2.70 |
| 9 | CL32A226KOJNNN □ | 22 μ F | | 16 | ±10% | 2.70 |
| 10 | CL32A226KOCCLNN □ | 22 μ F | | 16 | ±10% | 0.95 |
| 11 | CL32A226KPJNNN □ | 22 μ F | | 10 | ±10% | 2.70 |
| 12 | CL32A226KQJNNN □ | 22 μ F | | 6.3 | ±10% | 2.70 |
| 13 | CL32A226MQCLNN □ | 22 μ F | | 6.3 | ±20% | 0.95 |
| 14 | CL32A226KRJNNN □ | 22 μ F | | 4.0 | ±10% | 2.70 |
| 15 | CL32A226MRCCLNN □ | 22 μ F | | 4.0 | ±20% | 0.95 |
| 16 | CL32A476KPJNNN □ | 47 μ F | | 10 | ±10% | 2.70 |
| 17 | CL32A476MQJNNN □ | 47 μ F | | 6.3 | ±20% | 2.70 |
| 18 | CL32A476MRJNNN □ | 47 μ F | | 4.0 | ±20% | 2.70 |
| 19 | CL32A107MPVNNN □ | 100 μ F | | 10 | ±20% | 2.80 |
| 20 | CL32A107MQVNNN □ | 100 μ F | | 6.3 | ±20% | 2.80 |
| 21 | CL32A107MRVNNN □ | 100 μ F | | 4.0 | ±20% | 2.80 |
| 1 | CL43A476MQJNNN □ | 4.50 × 3.20 | 47 μ F | 6.3 | ±20% | 2.70 |
| 2 | CL43A476MRJNNN □ | | 47 μ F | 4.0 | ±20% | 2.70 |
| 3 | CL43A107KQLNNN □ | | 100 μ F | 6.3 | ±20% | 3.50 |
| 4 | CL43A107KRLNNN □ | | 100 μ F | 4.0 | ±20% | 3.50 |

※ □ mark means packaging code. If you want to learn the code or quantity in detail, please see p 80.

Product Lineup (High Capacitance-X6S)

| | Part Number | Size L × W (mm) | Capacitance | Rated Voltage (Vdc) | Capacitance Tolerance | Thickness Max. (mm) |
|----|------------------|-----------------|--------------|---------------------|-----------------------|---------------------|
| 1 | CL05X224KP5NNN □ | 1.00 × 0.50 | 0.22 μ F | 10 | ±10% | 0.55 |
| 2 | CL05X224KQ5NNN □ | | 0.22 μ F | 6.3 | ±10% | 0.55 |
| 3 | CL05X224KR5NNN □ | | 0.22 μ F | 4 | ±10% | 0.55 |
| 4 | CL05X474KP5NNN □ | | 0.47 μ F | 10 | ±10% | 0.55 |
| 5 | CL05X474KQ5NNN □ | | 0.47 μ F | 6.3 | ±10% | 0.55 |
| 6 | CL05X474KR5NNN □ | | 0.47 μ F | 4 | ±10% | 0.55 |
| 7 | CL05X105KP5NNN □ | | 1 μ F | 10 | ±10% | 0.55 |
| 8 | CL05X105MQ3LNN □ | | 1 μ F | 6.3 | ±20% | 0.33 |
| 9 | CL05X105KQ5NNN □ | | 1 μ F | 6.3 | ±10% | 0.55 |
| 10 | CL05X105MR3LNN □ | | 1 μ F | 4 | ±20% | 0.33 |
| 11 | CL05X105KR5NNN □ | | 1 μ F | 4 | ±10% | 0.55 |
| 12 | CL05X225MQ5NSN □ | | 2.2 μ F | 6.3 | ±20% | 0.57 |
| 13 | CL05X225MR5NSN □ | | 2.2 μ F | 4 | ±20% | 0.57 |
| 1 | CL10X474KA8NNN □ | 1.60 × 0.80 | 0.47 μ F | 25 | ±10% | 0.90 |
| 2 | CL10X474KO8NNN □ | | 0.47 μ F | 16 | ±10% | 0.90 |
| 3 | CL10X474KP8NNN □ | | 0.47 μ F | 10 | ±10% | 0.90 |
| 4 | CL10X474KQ8NNN □ | | 0.47 μ F | 6.3 | ±10% | 0.90 |
| 5 | CL10X474KR8NNN □ | | 0.47 μ F | 4 | ±10% | 0.90 |
| 6 | CL10X105KA8NNN □ | | 1 μ F | 25 | ±10% | 0.90 |
| 7 | CL10X105KO8NNN □ | | 1 μ F | 16 | ±10% | 0.90 |
| 8 | CL10X105KP8NNN □ | | 1 μ F | 10 | ±10% | 0.90 |
| 9 | CL10X105KQ8NNN □ | | 1 μ F | 6.3 | ±10% | 0.90 |
| 10 | CL10X105KR8NNN □ | | 1 μ F | 4 | ±10% | 0.90 |
| 11 | CL10X225KA8NQN □ | | 2.2 μ F | 25 | ±10% | 0.90 |
| 12 | CL10X225KO8NNN □ | | 2.2 μ F | 16 | ±10% | 0.90 |
| 13 | CL10X225KP8NNN □ | | 2.2 μ F | 10 | ±10% | 0.90 |
| 14 | CL10X225KQ8NNN □ | | 2.2 μ F | 6.3 | ±10% | 0.90 |
| 15 | CL10X225KR8NNN □ | | 2.2 μ F | 4 | ±10% | 0.90 |
| 16 | CL10X475KA8NQN □ | | 4.7 μ F | 25 | ±10% | 0.90 |
| 17 | CL10X475KO8NQN □ | | 4.7 μ F | 16 | ±10% | 0.90 |
| 18 | CL10X475KP5NNN □ | | 4.7 μ F | 10 | ±10% | 0.90 |
| 19 | CL10X475KQ8NNN □ | | 4.7 μ F | 6.3 | ±10% | 0.90 |
| 20 | CL10X475KR8NNN □ | | 4.7 μ F | 4 | ±10% | 0.90 |
| 21 | CL10X106MP8NNN □ | | 10 μ F | 10 | ±20% | 0.90 |
| 22 | CL10X106KQ8NNN □ | | 10 μ F | 6.3 | ±10% | 0.90 |
| 23 | CL10X106KR8NNN □ | | 10 μ F | 4 | ±10% | 0.90 |
| 1 | CL21X105KAFNNN □ | 2.00 × 1.25 | 1 μ F | 25 | ±10% | 1.35 |
| 2 | CL21X105KOFNNN □ | | 1 μ F | 16 | ±10% | 1.35 |
| 3 | CL21X105KPFNNN □ | | 1 μ F | 10 | ±10% | 1.35 |
| 4 | CL21X105KQFNNN □ | | 1 μ F | 6.3 | ±10% | 1.35 |
| 5 | CL21X105KRFNNN □ | | 1 μ F | 4 | ±10% | 1.35 |
| 6 | CL21X225KAFNNN □ | | 2.2 μ F | 25 | ±10% | 1.35 |
| 7 | CL21X225KOFNNN □ | | 2.2 μ F | 16 | ±10% | 1.35 |
| 8 | CL21X225KPFNNN □ | | 2.2 μ F | 10 | ±10% | 1.35 |
| 9 | CL21X225KQFNNN □ | | 2.2 μ F | 6.3 | ±10% | 1.35 |
| 10 | CL21X225KRFNNN □ | | 2.2 μ F | 4 | ±10% | 1.35 |
| 11 | CL21X475KAQNNN □ | | 4.7 μ F | 25 | ±10% | 1.40 |
| 12 | CL21X475KOFNNN □ | | 4.7 μ F | 16 | ±10% | 1.35 |
| 13 | CL21X475KPFNNN □ | | 4.7 μ F | 10 | ±10% | 1.35 |
| 14 | CL21X475KQFNNN □ | | 4.7 μ F | 6.3 | ±10% | 1.35 |

※ □ mark means packaging code. If you want to learn the code or quantity in detail, please see p 80.

Part Numbering System

General Capacitors

High Capacitance Capacitors

Super Small Size Capacitors

Medium-High Voltage Capacitors

Array Type Capacitors

Low ESL Capacitors

Reliability Test Condition

Premium Capacitors for Automotive Applications

Packaging Specification

Application Manual for Surface Mounting

Product Lineup (High Capacitance -X7R)

| | Part Number | Size L × W (mm) | Capacitance | Rated Voltage (Vdc) | Capacitance Tolerance | Thickness Max. (mm) |
|----|------------------|-----------------|-------------|---------------------|-----------------------|---------------------|
| 15 | CL21X475KRFNNN □ | 2.00×1.25 | 4.7 μ F | 4 | ±10% | 1.35 |
| 16 | CL21X106KACLRN □ | | 10 μ F | 25 | ±10% | 0.95 |
| 17 | CL21X106KAYNNN □ | | 10 μ F | 25 | ±10% | 1.45 |
| 18 | CL21X106KOYNNN □ | | 10 μ F | 16 | ±10% | 1.45 |
| 19 | CL21X106KPCLNN □ | | 10 μ F | 10 | ±10% | 0.95 |
| 20 | CL21X106KPYNNN □ | | 10 μ F | 10 | ±10% | 1.45 |
| 21 | CL21X106KQJNNN □ | | 10 μ F | 6.3 | ±10% | 1.40 |
| 22 | CL21X106KRQNNN □ | | 10 μ F | 4 | ±10% | 1.40 |
| 23 | CL21X106KRCLNN □ | | 10 μ F | 4 | ±10% | 0.95 |
| 24 | CL21X226MQJNNN □ | | 22 μ F | 6.3 | ±20% | 1.40 |
| 25 | CL21X226MRQNNN □ | | 22 μ F | 4 | ±20% | 1.40 |
| 26 | CL21X476MRYNNN □ | | 47 μ F | 4 | ±20% | 1.45 |
| 1 | CL31X475KAHNNN □ | 3.20×1.60 | 4.7 μ F | 25 | ±10% | 1.80 |
| 2 | CL31X475KACLNN □ | | 4.7 μ F | 25 | ±10% | 0.95 |
| 3 | CL31X475KOHNNN □ | | 4.7 μ F | 16 | ±10% | 1.80 |
| 4 | CL31X475KPHNNN □ | | 4.7 μ F | 10 | ±10% | 1.80 |
| 5 | CL31X475MQHNNN □ | | 4.7 μ F | 6.3 | ±20% | 1.80 |
| 6 | CL31X475KRHNNN □ | | 4.7 μ F | 4 | ±10% | 1.80 |
| 7 | CL31X106KACLNN □ | | 10 μ F | 25 | ±10% | 0.95 |
| 8 | CL31X106KAHNNN □ | | 10 μ F | 25 | ±10% | 1.80 |
| 9 | CL31X106KOHNNN □ | | 10 μ F | 16 | ±10% | 1.80 |
| 10 | CL31X106KPHNNN □ | | 10 μ F | 10 | ±10% | 1.80 |
| 11 | CL31X106KQHNNN □ | | 10 μ F | 6.3 | ±10% | 1.80 |
| 12 | CL31X106KRHNNN □ | | 10 μ F | 4 | ±10% | 1.80 |
| 13 | CL31X226KOHNNN □ | | 22 μ F | 16 | ±10% | 1.80 |
| 14 | CL31X226KPHNNN □ | | 22 μ F | 10 | ±10% | 1.80 |
| 15 | CL31X226KQHNNN □ | | 22 μ F | 6.3 | ±10% | 1.80 |
| 16 | CL31X226KRHNNN □ | | 22 μ F | 4 | ±10% | 1.80 |
| 17 | CL31X107MQHNNN □ | | 100 μ F | 6.3 | ±20% | 1.80 |
| 18 | CL31X107MRHNNN □ | | 100 μ F | 4 | ±20% | 1.80 |
| 1 | CL32X106KAUNNN □ | 3.20×2.50 | 10 μ F | 25 | ±10% | 2.00 |
| 2 | CL32X106KQJNNN □ | | 10 μ F | 16 | ±10% | 2.70 |
| 3 | CL32X106KPJNNN □ | | 10 μ F | 10 | ±10% | 2.70 |
| 4 | CL32X106KQJNNN □ | | 10 μ F | 6.3 | ±10% | 2.70 |
| 5 | CL32X106KRJNNN □ | | 10 μ F | 4 | ±10% | 2.70 |
| 6 | CL32X226KAJNNN □ | | 22 μ F | 25 | ±10% | 2.70 |
| 7 | CL32X226KQJNNN □ | | 22 μ F | 16 | ±10% | 2.70 |
| 8 | CL32X226KPJNNN □ | | 22 μ F | 10 | ±10% | 2.70 |
| 9 | CL32X226KQJNNN □ | | 22 μ F | 6.3 | ±10% | 2.70 |
| 10 | CL32X226KRJNNN □ | | 22 μ F | 4 | ±10% | 2.70 |
| 11 | CL32X476MPJNNN □ | | 47 μ F | 10 | ±20% | 2.70 |
| 12 | CL32X476KQJNNN □ | | 47 μ F | 6.3 | ±10% | 2.70 |
| 13 | CL32X476KRJNNN □ | | 47 μ F | 4 | ±10% | 2.70 |
| 14 | CL32X107MQVNNN □ | | 100 μ F | 6.3 | ±20% | 2.70 |
| 15 | CL32X107MRVNNN □ | | 100 μ F | 4 | ±20% | 2.70 |

※ □mark means packaging code. If you want to learn the code or quantity in detail, please see p80.

Product Lineup (High Capacitance -X7R)

| | Part Number | Size L × W (mm) | Capacitance | Rated Voltage (Vdc) | Capacitance Tolerance | Thickness Max. (mm) |
|----|------------------|-----------------|--------------|---------------------|-----------------------|---------------------|
| 1 | CL05B224KO5NNN □ | 1.00×0.50 | 0.22 μ F | 16 | ±10% | 0.55 |
| 2 | CL05B224KP5NNN □ | | 0.22 μ F | 10 | ±10% | 0.55 |
| 3 | CL05B224KQ5NNN □ | | 0.22 μ F | 6.3 | ±10% | 0.55 |
| 1 | CL10B474KA8NNN □ | 1.60×0.80 | 0.47 μ F | 25 | ±10% | 0.90 |
| 2 | CL10B474KO8NNN □ | | 0.47 μ F | 16 | ±10% | 0.90 |
| 3 | CL10B474KP8NNN □ | | 0.47 μ F | 10 | ±10% | 0.90 |
| 4 | CL10B474KQ8NNN □ | | 0.47 μ F | 6.3 | ±10% | 0.90 |
| 5 | CL10B105KA8NNN □ | | 1 μ F | 25 | ±10% | 0.90 |
| 6 | CL10B105KO8NNN □ | | 1 μ F | 16 | ±10% | 0.90 |
| 7 | CL10B105KP8NNN □ | | 1 μ F | 10 | ±10% | 0.90 |
| 8 | CL10B105KQ8NNN □ | | 1 μ F | 6.3 | ±10% | 0.90 |
| 9 | CL10B225KP8NNN □ | | 2.2 μ F | 10 | ±10% | 0.90 |
| 10 | CL10B225KQ8NNN □ | | 2.2 μ F | 6.3 | ±10% | 0.90 |
| 1 | CL21B105KBFNNN □ | 2.00×1.25 | 1 μ F | 50 | ±10% | 1.35 |
| 2 | CL21B105KLFNNN □ | | 1 μ F | 35 | ±10% | 1.35 |
| 3 | CL21B105KAFNNN □ | | 1 μ F | 25 | ±10% | 1.35 |
| 4 | CL21B105KOFNNN □ | | 1 μ F | 16 | ±10% | 1.35 |
| 5 | CL21B105KPFNNN □ | | 1 μ F | 10 | ±10% | 1.35 |
| 6 | CL21B105KQFNNN □ | | 1 μ F | 6.3 | ±10% | 1.35 |
| 7 | CL21B225KAFNNN □ | | 2.2 μ F | 25 | ±10% | 1.35 |
| 8 | CL21B225KOFNNN □ | | 2.2 μ F | 16 | ±10% | 1.35 |
| 9 | CL21B225KPFNNN □ | | 2.2 μ F | 10 | ±10% | 1.35 |
| 10 | CL21B225KQFNNN □ | | 2.2 μ F | 6.3 | ±10% | 1.35 |
| 11 | CL21B475KOFNFN □ | | 4.7 μ F | 16 | ±10% | 1.35 |
| 12 | CL21B475KPFNFN □ | | 4.7 μ F | 10 | ±10% | 1.35 |
| 13 | CL21B475KQJNNN □ | | 4.7 μ F | 6.3 | ±10% | 1.35 |
| 14 | CL21B106KQJNNN □ | | 10 μ F | 16 | ±10% | 1.40 |
| 15 | CL21B106KQJNNN □ | | 10 μ F | 10 | ±10% | 1.35 |
| 16 | CL21B106KQJNNN □ | | 10 μ F | 6.3 | ±10% | 1.35 |
| 1 | CL31B475KBHNNN □ | 3.20×1.60 | 4.7 μ F | 50 | ±10% | 1.80 |
| 2 | CL31B475KLHNNN □ | | 4.7 μ F | 35 | ±10% | 1.80 |
| 3 | CL31B475KAHNNN □ | | 4.7 μ F | 25 | ±10% | 1.80 |
| 4 | CL31B475KOHNNN □ | | 4.7 μ F | 16 | ±10% | 1.80 |
| 5 | CL31B475KPHNNN □ | | 4.7 μ F | 10 | ±10% | 1.80 |
| 6 | CL31B475KQHNNN □ | | 4.7 μ F | 6.3 | ±10% | 1.80 |
| 7 | CL31B106LHNNN □ | | 10 μ F | 35 | ±10% | 1.80 |
| 8 | CL31B106KAHNNN □ | | 10 μ F | 25 | ±10% | 1.80 |
| 9 | CL31B106KOHNNN □ | | 10 μ F | 16 | ±10% | 1.80 |
| 10 | CL31B106KPHNNN □ | | 10 μ F | 10 | ±10% | 1.80 |
| 11 | CL31B106KQHNNN □ | | 10 μ F | 6.3 | ±10% | 1.80 |
| 1 | CL32B106KBJNNN □ | 3.20×2.50 | 10 μ F | 50 | ±10% | 2.70 |
| 2 | CL32B106KAJNNN □ | | 10 μ F | 25 | ±10% | 2.70 |
| 3 | CL32B106KQJNNN □ | | 10 μ F | 16 | ±10% | 2.70 |
| 4 | CL32B106KPJNNN □ | | 10 μ F | 10 | ±10% | 2.70 |
| 5 | CL32B106KQJNNN □ | | 10 μ F | 6.3 | ±10% | 2.70 |
| 6 | CL32B226KAJNNN □ | | 22 μ F | 25 | ±10% | 2.70 |
| 7 | CL32B226KQJNNN □ | | 22 μ F | 16 | ±10% | 2.70 |
| 8 | CL32B226KPJNNN □ | | 22 μ F | 10 | ±10% | 2.70 |
| 9 | CL32B226KQJNNN □ | | 22 μ F | 6.3 | ±10% | 2.70 |
| 10 | CL32B476MQJNNN □ | | 47 μ F | 6.3 | ±20% | 2.70 |

※ □mark means packaging code. If you want to learn the code or quantity in detail, please see p80.

- Part Numbering System
- General Capacitors
- High Capacitance Capacitors
- Super Small Size Capacitors
- Medium-High Voltage Capacitors
- Array Type Capacitors
- Low ESL Capacitors
- Reliability Test Condition
- Premium Capacitors for Automotive Applications
- Packaging Specification
- Application Manual for Surface Mounting

Product Lineup (High Capacitance -Y5V)

| | Part Number | Size L × W (mm) | Capacitance | Rated Voltage (Vdc) | Capacitance Tolerance | Thickness Max. (mm) | |
|---|------------------|-----------------|-------------|---------------------|-----------------------|---------------------|------|
| 1 | CL05F224Z05NNN □ | 1.00×0.50 | 0.22μF | 16 | 80%/-20% | 0.55 | |
| 2 | CL05F224ZP5NNN □ | | 0.22μF | 10 | 80%/-20% | 0.55 | |
| 3 | CL05F224ZQ5NNN □ | | 0.22μF | 6.3 | 80%/-20% | 0.55 | |
| 4 | CL05F474ZP5NNN □ | | 0.47μF | 10 | 80%/-20% | 0.55 | |
| 5 | CL05F474ZQ5NNN □ | | 0.47μF | 6.3 | 80%/-20% | 0.55 | |
| 6 | CL05F105ZQ5NNN □ | | 1μF | 6.3 | 80%/-20% | 0.55 | |
| 1 | CL10F474ZB8NNN □ | 1.60×0.80 | 0.47μF | 50 | 80%/-20% | 0.90 | |
| 2 | CL10F474ZA8NNN □ | | 0.47μF | 25 | 80%/-20% | 0.90 | |
| 3 | CL10F474ZO8NNN □ | | 0.47μF | 16 | 80%/-20% | 0.90 | |
| 4 | CL10F474ZP8NNN □ | | 0.47μF | 10 | 80%/-20% | 0.90 | |
| 5 | CL10F105ZO8NNN □ | | 1μF | 16 | 80%/-20% | 0.90 | |
| 6 | CL10F105ZP8NNN □ | | 1μF | 10 | 80%/-20% | 0.90 | |
| 7 | CL10F225ZP8NNN □ | | 2.2μF | 10 | 80%/-20% | 0.90 | |
| 8 | CL10F225ZQ8NNN □ | | 2.2μF | 6.3 | 80%/-20% | 0.90 | |
| 9 | CL10F475ZQ8NNN □ | | 4.7μF | 6.3 | 80%/-20% | 0.90 | |
| 1 | CL21F105ZBFNNN □ | 2.00×1.25 | 1μF | 50 | 80%/-20% | 1.35 | |
| 2 | CL21F105ZAFNNN □ | | 1μF | 25 | 80%/-20% | 1.35 | |
| 3 | CL21F105ZOFNNN □ | | 1μF | 16 | 80%/-20% | 1.35 | |
| 4 | CL21F225ZAFNNN □ | | 2.2μF | 25 | 80%/-20% | 1.35 | |
| 5 | CL21F225ZOFNNN □ | | 2.2μF | 16 | 80%/-20% | 1.35 | |
| 6 | CL21F475ZQFNNN □ | | 4.7μF | 6.3 | 80%/-20% | 1.35 | |
| 1 | CL21F475ZOFNNN □ | | 4.7μF | 16 | 80%/-20% | 1.35 | |
| 2 | CL21F475ZPFNNN □ | | 4.7μF | 10 | 80%/-20% | 1.35 | |
| 3 | CL21F106ZPFNNN □ | | 10μF | 10 | 80%/-20% | 1.35 | |
| 4 | CL21F106ZPCLNN □ | | 10μF | 10 | 80%/-20% | 0.95 | |
| 5 | CL21F106ZQFNNN □ | | 10μF | 6.3 | 80%/-20% | 1.35 | |
| 6 | CL21F106ZQCLNN □ | | 10μF | 6.3 | 80%/-20% | 0.95 | |
| 1 | CL31F475ZOHNNN □ | | 3.20×1.60 | 4.7μF | 16 | 80%/-20% | 1.80 |
| 2 | CL31F475ZPHNNN □ | | | 4.7μF | 10 | 80%/-20% | 1.80 |
| 3 | CL31F475ZQHNNN □ | | | 4.7μF | 6.3 | 80%/-20% | 1.80 |
| 4 | CL31F106ZOHNNN □ | | | 10μF | 16 | 80%/-20% | 1.80 |
| 5 | CL31F106ZPHNNN □ | | | 10μF | 10 | 80%/-20% | 1.80 |
| 6 | CL31F106ZQHNNN □ | | | 10μF | 6.3 | 80%/-20% | 1.80 |
| 7 | CL31F226ZPHNNN □ | 22μF | | 10 | 80%/-20% | 1.80 | |
| 8 | CL31F226ZQHNNN □ | 22μF | | 6.3 | 80%/-20% | 1.80 | |
| 1 | CL32F106ZAHLNN □ | 3.20×2.50 | 10μF | 25 | 80%/-20% | 1.80 | |
| 2 | CL32F106ZOELNN □ | | 10μF | 16 | 80%/-20% | 2.00 | |
| 3 | CL32F226ZPJNNN □ | | 22μF | 10 | 80%/-20% | 2.70 | |
| 4 | CL32F226ZPULNN □ | | 22μF | 10 | 80%/-20% | 2.00 | |
| 5 | CL32F476ZQJNNN □ | | 47μF | 6.3 | 80%/-20% | 2.70 | |
| 6 | CL32F107ZQJNNN □ | | 100μF | 6.3 | 80%/-20% | 2.70 | |

※ □mark means packaging code. If you want to learn the code or quantity in detail, please see p80.

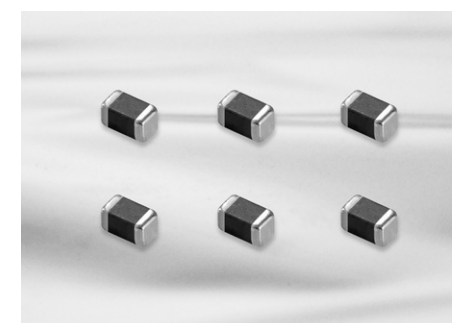

Feature

- Small chip size
- 03 Series(COG) MLCC shows very low ESR value.
- 02 and 03 Series are suited to only reflow soldering
- 02 and 03 Series are suited to miniature RF module, portable equipment and high frequency circuit

Application

- VCO, Tuner, RF Module
- MCM Module
- Mobile phone, Wireless LAN, Note PC
- ※ For using special purpose like Military, Medical, Aviation, Automobile device should be following a special specification.

Structure and Dimensions

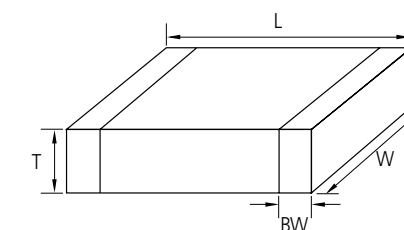

| Code | EIA Code | Dimension(mm) | | | |
|------|----------|---------------|----------|----------|-----------|
| | | L | W | T | BW |
| 02 | 01005 | 0.4±0.02 | 0.2±0.02 | 0.2±0.02 | 0.07~0.14 |
| 03 | 0201 | 0.6±0.03 | 0.3±0.03 | 0.3±0.03 | 0.15±0.05 |

Part Numbering System

General Capacitors

High Capacitance Capacitors

Super Small Size Capacitors

Medium-High Voltage Capacitors

Array Type Capacitors

Low ESL Capacitors

Reliability Test Condition

Premium Capacitors for Automotive Applications

Packaging Specification

Application Manual for Surface Mounting

Super Small Size Capacitance Table (C0G)

| Size(mm) | Tmax (mm) | Vr(V) | Capacitance (pF) | | | | | | | |
|----------|-------------|-------|------------------|---|----|----|----|-----|------|-----|
| | | | 0.5 | 1 | 10 | 22 | 47 | 100 | 220 | 330 |
| C0G | 01005(0402) | 6.3 | | | | | | | | |
| | | 16 | | | | | | | | |
| | 0201(0603) | 25 | | | | | | | | |
| | | 50 | | | | | | | 20pF | |

Super Small Size Capacitance Table (X5R, X7R, Y5V)

| TC | Size (mm) | Vr(V) | Capacitance (uF) | | | | | | | |
|-----|-------------|-------|------------------|------|------|---|-----|-----|----|----|
| | | | 0.1 | 0.22 | 0.47 | 1 | 2.2 | 4.7 | 10 | 22 |
| C0G | 01005(0402) | 6.3 | | | | | | | | |
| | | 4 | X5R or X6S | | | | | | | |
| | 0201(0603) | 6.3 | | | | | | | | |
| | | 10 | | | | | | | | |
| | | 16 | | | | | | | | |
| | | 25 | | | | | | | | |
| X7R | 01005(0402) | 10 | | | | | | | | |
| | | 10 | | | | | | | | |
| | 0201(0603) | 16 | | | | | | | | |
| Y5V | 0201(0603) | 6.3 | | | | | | | | |

Product Lineup (Super Small Size Capacitors -C0G)

| | Part Number | Size L×W (mm) | Capacitance | Rated Voltage (Vdc) | Capacitance Tolerance | Thickness Max. (mm) | |
|----|------------------|---------------|-------------|---------------------|-----------------------|---------------------|--------|
| 1 | CL02C0R5CO2ANN □ | 0.40×0.20 | 0.5pF | 16 | ±0.25pF | 0.22 | |
| 2 | CL02C010CO2ANN □ | | 1.0pF | 16 | ±0.25pF | 0.22 | |
| 3 | CL02C1R2CO2ANN □ | | 1.2pF | 16 | ±0.25pF | 0.22 | |
| 4 | CL02C1R5CO2ANN □ | | 1.5pF | 16 | ±0.25pF | 0.22 | |
| 5 | CL02C1R8CO2ANN □ | | 1.8pF | 16 | ±0.25pF | 0.22 | |
| 6 | CL02C020CO2ANN □ | | 2.0pF | 16 | ±0.25pF | 0.22 | |
| 7 | CL02C2R2CO2ANN □ | | 2.2pF | 16 | ±0.25pF | 0.22 | |
| 8 | CL02C2R7CO2ANN □ | | 2.7pF | 16 | ±0.25pF | 0.22 | |
| 9 | CL02C030CO2ANN □ | | 3.0pF | 16 | ±0.25pF | 0.22 | |
| 10 | CL02C3R3CO2ANN □ | | 3.3pF | 16 | ±0.25pF | 0.22 | |
| 11 | CL02C3R9CO2ANN □ | | 3.9pF | 16 | ±0.25pF | 0.22 | |
| 12 | CL02C4R7CO2ANN □ | | 4.7pF | 16 | ±0.25pF | 0.22 | |
| 13 | CL02C5R6DO2ANN □ | | 5.6pF | 16 | ±0.5pF | 0.22 | |
| 14 | CL02C6R8DO2ANN □ | | 6.8pF | 16 | ±0.5pF | 0.22 | |
| 15 | CL02C8R2DO2ANN □ | | 8.2pF | 16 | ±0.5pF | 0.22 | |
| 16 | CL02C090DO2ANN □ | | 9.0pF | 16 | ±0.5pF | 0.22 | |
| 17 | CL02C100JO2ANN □ | | 10pF | 16 | ±5% | 0.22 | |
| 18 | CL02C150JO2ANN □ | | 15pF | 16 | ±5% | 0.22 | |
| 19 | CL02C180JO2ANN □ | | 18pF | 16 | ±5% | 0.22 | |
| 20 | CL02C220JO2ANN □ | | 22pF | 16 | ±5% | 0.22 | |
| 21 | CL02C270JO2ANN □ | | 27pF | 16 | ±5% | 0.22 | |
| 22 | CL02C330JO2ANN □ | | 33pF | 16 | ±5% | 0.22 | |
| 23 | CL02C390JO2ANN □ | | 39pF | 16 | ±5% | 0.22 | |
| 24 | CL02C470JO2ANN □ | | 47pF | 16 | ±5% | 0.22 | |
| 25 | CL02C560JQ2ANN □ | | 56pF | 6.3 | ±5% | 0.22 | |
| 26 | CL02C680JQ2ANN □ | | 68pF | 6.3 | ±5% | 0.22 | |
| 27 | CL02C820JQ2ANN □ | | 82pF | 6.3 | ±5% | 0.22 | |
| 28 | CL02C101JQ2ANN □ | | 100pF | 6.3 | ±5% | 0.22 | |
| 1 | CL03C0R5CA3GNN □ | 0.60×0.30 | 0.5pF | 25 | ±0.25pF | 0.33 | High-Q |
| 2 | CL03C010CA3GNN □ | | 1.0pF | 25 | ±0.25pF | 0.33 | High-Q |
| 3 | CL03C1R2CA3GNN □ | | 1.2pF | 25 | ±0.25pF | 0.33 | High-Q |
| 4 | CL03C1R5CA3GNN □ | | 1.5pF | 25 | ±0.25pF | 0.33 | High-Q |
| 5 | CL03C1R8CA3GNN □ | | 1.8pF | 25 | ±0.25pF | 0.33 | High-Q |
| 6 | CL03C020CA3GNN □ | | 2.0pF | 25 | ±0.25pF | 0.33 | High-Q |
| 7 | CL03C2R2CA3GNN □ | | 2.2pF | 25 | ±0.25pF | 0.33 | High-Q |
| 8 | CL03C2R7CA3GNN □ | | 2.7pF | 25 | ±0.25pF | 0.33 | High-Q |
| 9 | CL03C030CA3GNN □ | | 3.0pF | 25 | ±0.25pF | 0.33 | High-Q |
| 10 | CL03C3R3CA3GNN □ | | 3.3pF | 25 | ±0.25pF | 0.33 | High-Q |
| 11 | CL03C3R9CA3GNN □ | | 3.9pF | 25 | ±0.25pF | 0.33 | High-Q |
| 12 | CL03C4R7CA3GNN □ | | 4.7pF | 25 | ±0.25pF | 0.33 | High-Q |
| 13 | CL03C5R6DA3GNN □ | | 5.6pF | 25 | ±0.5pF | 0.33 | High-Q |
| 14 | CL03C6R8DA3GNN □ | | 6.8pF | 25 | ±0.5pF | 0.33 | High-Q |
| 15 | CL03C8R2DA3GNN □ | | 8.2pF | 25 | ±0.5pF | 0.33 | High-Q |
| 16 | CL03C090DA3GNN □ | | 9.0pF | 25 | ±0.5pF | 0.33 | High-Q |
| 17 | CL03C100JA3GNN □ | | 10pF | 25 | ±5% | 0.33 | High-Q |
| 18 | CL03C150JA3GNN □ | | 15pF | 25 | ±5% | 0.33 | High-Q |
| 19 | CL03C180JA3GNN □ | | 18pF | 25 | ±5% | 0.33 | High-Q |
| 20 | CL03C220JA3GNN □ | | 22pF | 25 | ±5% | 0.33 | High-Q |
| 21 | CL03C270JA3GNN □ | | 27pF | 25 | ±5% | 0.33 | High-Q |
| 22 | CL03C330JA3GNN □ | | 33pF | 25 | ±5% | 0.33 | High-Q |
| 23 | CL03C390JA3ANN □ | | 39pF | 25 | ±5% | 0.33 | |
| 24 | CL03C470JA3ANN □ | | 47pF | 25 | ±5% | 0.33 | |
| 25 | CL03C101JA3ANN □ | | 100pF | 25 | ±5% | 0.33 | |

Part Numbering System

General Capacitors

High Capacitance Capacitors

Super Small Size Capacitors

Medium-High Voltage Capacitors

Array Type Capacitors

Low ESL Capacitors

Reliability Test Condition

Premium Capacitors for Automotive Applications

Packaging Specification

Application Manual for Surface Mounting

※ □ mark means packaging code. If you want to learn the code or quantity in detail, please see p80.

Product Lineup (Super Small Size Capacitors -X7R)

| | Part Number | Size L × W (mm) | Capacitance | Rated Voltage (Vdc) | Capacitance Tolerance | Thickness Max. (mm) |
|---|------------------|-----------------|-------------|---------------------|-----------------------|---------------------|
| 1 | CL02B101KP2NNN □ | 0.40×0.20 | 100pF | 10 | ±10% | 0.22 |
| 2 | CL02B151KP2NNN □ | | 150pF | 10 | ±10% | 0.22 |
| 3 | CL02B221KP2NNN □ | | 220pF | 10 | ±10% | 0.22 |
| 4 | CL02B331KP2NNN □ | | 330pF | 10 | ±10% | 0.22 |
| 5 | CL02B471KP2NNN □ | | 470pF | 10 | ±10% | 0.22 |
| 6 | CL02B681KP2NNN □ | | 680pF | 10 | ±10% | 0.22 |
| 7 | CL02B102KP2NNN □ | | 1.0nF | 10 | ±10% | 0.22 |
| 1 | CL03B331KO3NNN □ | 0.60×0.30 | 330pF | 16 | ±10% | 0.33 |
| 2 | CL03B102KO3NNN □ | | 1nF | 16 | ±10% | 0.33 |
| 3 | CL03B472KQ3NNN □ | | 4.7nF | 6.3 | ±10% | 0.33 |
| 4 | CL03B103KP3NNN □ | | 10nF | 10 | ±10% | 0.33 |

Product Lineup (Super Small Size Capacitors -X5R)

| | Part Number | Size L × W (mm) | Capacitance | Rated Voltage (Vdc) | Capacitance Tolerance | Thickness Max. (mm) |
|----|------------------|-----------------|-------------|---------------------|-----------------------|---------------------|
| 1 | CL02A151KQ2NNN □ | 0.40×0.20 | 150pF | 6.3 | ±10% | 0.22 |
| 2 | CL02A221KQ2NNN □ | | 220pF | 6.3 | ±10% | 0.22 |
| 3 | CL02A331KQ2NNN □ | | 330pF | 6.3 | ±10% | 0.22 |
| 4 | CL02A471KQ2NNN □ | | 470pF | 6.3 | ±10% | 0.22 |
| 5 | CL02A681KQ2NNN □ | | 680pF | 6.3 | ±10% | 0.22 |
| 6 | CL02A102KQ2NNN □ | | 1nF | 6.3 | ±10% | 0.22 |
| 7 | CL02A152KQ2NNN □ | | 1.5nF | 6.3 | ±10% | 0.22 |
| 8 | CL02A222KQ2NNN □ | | 2.2nF | 6.3 | ±10% | 0.22 |
| 9 | CL02A332KQ2NNN □ | | 3.2nF | 6.3 | ±10% | 0.22 |
| 10 | CL02A472KQ2NNN □ | | 4.7nF | 6.3 | ±10% | 0.22 |
| 11 | CL02A682KQ2NNN □ | | 6.8nF | 6.3 | ±10% | 0.22 |
| 12 | CL02A103KQ2NNN □ | | 10nF | 6.3 | ±10% | 0.22 |
| 13 | CL02A104KQ2NNN □ | | 100nF | 6.3 | ±10% | 0.22 |
| 1 | CL03A103KP3NNN □ | 0.60×0.30 | 10nF | 10 | ±10% | 0.33 |
| 2 | CL03A223KQ3NNN □ | | 22nF | 6.3 | ±10% | 0.33 |
| 3 | CL03A473KQ3NNN □ | | 47nF | 6.3 | ±10% | 0.33 |
| 4 | CL03A104MA3NNN □ | | 100nF | 25 | ±20% | 0.33 |
| 5 | CL03A104KO3NNN □ | | 100nF | 16 | ±10% | 0.33 |
| 6 | CL03A104KP3NNN □ | | 100nF | 10 | ±10% | 0.33 |
| 7 | CL03A104KQ3NNN □ | | 100nF | 6.3 | ±10% | 0.33 |
| 8 | CL03A224KQ3NNN □ | | 220nF | 6.3 | ±10% | 0.33 |
| 9 | CL03A224KP3NNN □ | | 200nF | 10 | ±10% | 0.33 |
| 10 | CL03A105MQ3CSN □ | | 1μF | 6.3 | ±20% | 0.35 |

※ □mark means packaging code. If you want to learn the code or quantity in detail, please see p80.

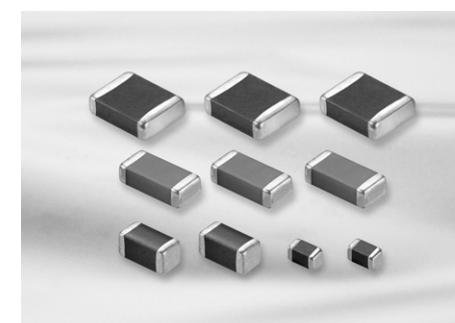

Feature

- Highly reliable performance
- Operating at high voltage level
- Wide voltage level: from 100V to 3000V
- High withstanding voltage
- Tape & reel surface mount assembly

Application

- Switching Power Circuit(SMPS)
 - Lighting Ballast, LCD back lighting inverter
 - DC-DC converter input filter, snubber circuit
 - Phone, Fax, Modem
 - Network(IEEE802.3)
- ※ For using special purpose like Military, Medical, Aviation, Automobile device should be following a special specification.

Structure and Dimensions

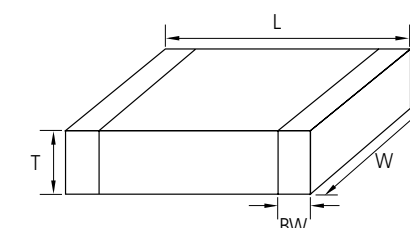

| Code | EIA Code | Dimension(mm) | | | |
|------|----------|---------------|----------|-----------|--------------|
| | | L | W | T | BW |
| 10 | 0603 | 1.6±0.1 | 0.8±0.1 | 0.8±0.1 | 0.3±0.2 |
| 21 | 0805 | 2.0±0.1 | 1.25±0.1 | 1.25±0.1 | 0.5+0.2/-0.3 |
| 31 | 1206 | 3.2±0.2 | 1.6±0.2 | 1.6±0.2 | 0.5±0.3 |
| | | 3.2±0.15 | 1.6±0.15 | 0.85±0.15 | |
| 32 | 1210 | 3.2±0.3 | 2.5±0.2 | 2.5±0.2 | 0.6±0.3 |
| 42 | 1808 | 4.5±0.4 | 2.0±0.2 | 2.0±0.2 | 0.8±0.3 |
| 43 | 1812 | 4.5±0.4 | 3.2±0.3 | 2.5±0.2 | 0.8±0.3 |
| 55 | 2220 | 5.7±0.4 | 5.0±0.4 | 2.5±0.2 | 1.0±0.3 |

Part Numbering System

General Capacitors

High Capacitance Capacitors

Super Small Size Capacitors

Medium-High Voltage Capacitors

Array Type Capacitors

Low ESL Capacitors

Reliability Test Condition

Premium Capacitors for Automotive Applications

Packaging Specification

Application Manual for Surface Mounting

Medium-High Voltage Capacitors Table (C0G)

| Vr | Size(mm) | Capacitance | | | | | | | | | | | | | | | | | | | | | | | | | |
|------|------------|-------------|-----|-----|-----|-----|------|---|-----|-----|-----|-----|-----|-----|-----|-----|-----|-----|-----|----|----|----|----|----|----|----|----|
| | | (pF) | | | | | (nF) | | | | | | | | | | | | | | | | | | | | |
| | | 330 | 390 | 470 | 560 | 680 | 820 | 1 | 1.2 | 1.5 | 1.8 | 2.2 | 2.7 | 3.3 | 3.9 | 4.7 | 5.6 | 6.8 | 8.2 | 10 | 12 | 15 | 18 | 22 | 27 | 33 | 47 |
| 100V | 0603(1608) | ■ | | | | | | | | | | | | | | | | | | | | | | | | | |
| | 0805(2012) | ■ | | | | | | | | | | | | | | | | | | | | | | | | | |
| | 1206(3216) | ■ | | | | | | | | | | | | | | | | | | | | | | | | | |
| | 1210(3225) | | | | | | ■ | | ■ | | | | | | | | | | | | | | | | | | |
| | 1812(4532) | | | | | | | | | | | ■ | | | | | | | | | | | | | | | |
| | 2220(5750) | | | | | | | | | | | | | | | | ■ | | | | | | | | | | |
| 200V | 0603(1608) | ■ | | | | | | | | | | | | | | | | | | | | | | | | | |
| | 0805(2012) | ■ | | | | | | | | | | | | | | | | | | | | | | | | | |
| | 1206(3216) | ■ | | | | | | | | | | | | | | | | | | | | | | | | | |
| | 1210(3225) | | | | | | ■ | | | | | | | | | | | | | | | | | | | | |
| | 1812(4532) | | | | | | | | | | | ■ | | | | | | | | | | | | | | | |
| | 2220(5750) | | | | | | | | | | | | | | | | ■ | | | | | | | | | | |
| 250V | 0603(1608) | ■ | | | | | | | | | | | | | | | | | | | | | | | | | |
| | 0805(2012) | ■ | | | | | | | | | | | | | | | | | | | | | | | | | |
| | 1206(3216) | ■ | | | | | | | | | | | | | | | | | | | | | | | | | |
| | 1210(3225) | | | | | | ■ | | | | | | | | | | | | | | | | | | | | |
| | 1812(4532) | | | | | | | | | | | ■ | | | | | | | | | | | | | | | |
| | 2220(5750) | | | | | | | | | | | | | | | | ■ | | | | | | | | | | |
| 500V | 1206(3216) | ■ | | | | | | | | | | | | | | | | | | | | | | | | | |
| | 1210(3225) | | | | | | ■ | | | | | | | | | | | | | | | | | | | | |
| | 1812(4532) | | | | | | | | | | | ■ | | | | | | | | | | | | | | | |
| | 2220(5750) | | | | | | | | | | | | | | | | ■ | | | | | | | | | | |
| 630V | 1206(3216) | ■ | | | | | | | | | | | | | | | | | | | | | | | | | |
| | 1210(3225) | | | | | | ■ | | | | | | | | | | | | | | | | | | | | |
| | 1812(4532) | | | | | | | | | | | ■ | | | | | | | | | | | | | | | |
| | 2220(5750) | | | | | | | | | | | | | | | | ■ | | | | | | | | | | |

Medium-High Voltage Capacitors Table (C0G)

| Vr | Size(mm) | Capacitance | | | | | | | | | | | | | | | | | | | | | | | | |
|-----|------------|-------------|----|----|----|-----|-----|-----|-----|-----|-----|------|-----|-----|-----|-----|-----|---|-----|-----|-----|-----|-----|-----|-----|-----|
| | | (pF) | | | | | | | | | | (nF) | | | | | | | | | | | | | | |
| | | 47 | 56 | 68 | 82 | 100 | 120 | 150 | 180 | 220 | 270 | 330 | 390 | 470 | 560 | 680 | 820 | 1 | 1.2 | 1.5 | 1.8 | 2.2 | 2.7 | 3.3 | 3.9 | 4.7 |
| 1KV | 1206(3216) | ■ | | | | | | | | | | | | | | | | | | | | | | | | |
| | 1210(3225) | | | | | | | | | | | ■ | | | | | | | | | | | | | | |
| | 1812(4532) | | | | | | | | | | | ■ | | | | | | | | | | | | | | |
| | 2220(5750) | | | | | | | | | | | ■ | | | | | | | | | | | | | | |
| 2KV | 1206(3216) | ■ | | | | | | | | | | | | | | | | | | | | | | | | |
| | 1210(3225) | ■ | | | | | | | | | | | | | | | | | | | | | | | | |
| | 1808(4520) | ■ | | | | | | | | | | | | | | | | | | | | | | | | |
| | 1812(4532) | ■ | | | | | | | | | | | | | | | | | | | | | | | | |
| 3KV | 2220(5750) | | | | | | | | | | | | | | | | ■ | | | | | | | | | |
| | 1808(4520) | ■ | | | | | | | | | | | | | | | | | | | | | | | | |
| | 1812(4532) | | | | | | | | | | | ■ | | | | | | | | | | | | | | |

Part Numbering System

General Capacitors

High Capacitance Capacitors

Super Small Size Capacitors

Medium-High Voltage Capacitors

Array Type Capacitors

Low ESL Capacitors

Reliability Test Condition

Premium Capacitors for Automotive Applications

Packaging Specification

Application Manual for Surface Mounting

Medium-High Voltage Capacitors Table (X7R)

| Size(mm) | Vr(V) | Capacitance (nF) | | | | | | | | | | | | | | | | | |
|----------|------------|------------------|----|---------------|----|----|--------------|----|-----|-----|-----|-----|-----|-----|------|------|------|------|--|
| | | 4.7 | 10 | 15 | 22 | 33 | 47 | 68 | 100 | 150 | 220 | 330 | 470 | 680 | 1000 | 1500 | 2200 | 4700 | |
| 100V | 0603(1608) | ■ | | | | | | | | | | | | | | | | | |
| | 0805(2012) | ■ | | | | | | | | | | | | | | | | | |
| | 1206(3216) | ■ | | | | | | | | | | | | | | | | | |
| | 1210(3225) | ■ | | | | | | | | | | | | | | | | | |
| | 1812(4532) | | | | | | | | ■ | | | | | | | | | | |
| | 2220(5750) | | | | | | | | | | | | | ■ | | | | | |
| 200V | 0805(2012) | ■ | | | | | | | | | | | | | | | | | |
| | 1206(3216) | ■ | | | | | | | | | | | | | | | | | |
| | 1210(3225) | | | | | | | ■ | | | | | | | | | | | |
| | 1812(4532) | | | | | ■ | | | | | | | | | | | | | |
| | 2220(5750) | | | | | | | | | | | ■ | | | | | | | |
| 250V | 0805(2012) | ■ | | | | | | | | | | | | | | | | | |
| | 1206(3216) | | | | | | ■ | | | | | | | | | | | | |
| | 1210(3225) | | | | | | | | ■ | | | | | | | | | | |
| | 1812(4532) | | | | | | | | | ■ | | | | | | | | | |
| | 2220(5750) | | | | | | | | | | | | ■ | | | | | | |
| 350V | 1206(3216) | ■ (Tmax=1.0) | | ■ (Tmax=1.25) | | | ■ (Tmax=1.8) | | | | | | | | | | | | |
| 500V | 1206(3216) | ■ | | | | | | | | | | | | | | | | | |
| | 1210(3225) | ■ | | | | | | | | | | | | | | | | | |
| | 1812(4532) | ■ | | | | ■ | | | | | | | | | | | | | |
| | 2220(5750) | | | | | | | | | | | ■ | | | | | | | |
| 630V | 1206(3216) | ■ | | | | | | | | | | | | | | | | | |
| | 1210(3225) | ■ | | | | | | | | | | | | | | | | | |
| | 1812(4532) | ■ | | | | ■ | | | | | | | | | | | | | |
| | 2220(5750) | | | | | | | | | | | ■ | | | | | | | |

Medium-High Voltage Capacitors Table (X7R)

| Size(mm) | Vr(V) | Capacitance (nF) | | | | | | | | | | | | | | | |
|----------|------------|------------------|-----|-----|-----|-----|-----|----|----|----|----|----|----|-----|-----|-----|-----|
| | | 1 | 1.5 | 2.2 | 3.3 | 4.7 | 6.8 | 10 | 15 | 22 | 33 | 47 | 68 | 100 | 150 | 220 | 330 |
| 1K | 1206(3216) | ■ | | | | | | | | | | | | | | | |
| | 1210(3225) | | | | | | | | | | | | ■ | | | | |
| | 1812(4532) | | | | | ■ | | | | | | | | | | | |
| | 2220(5750) | | | | | | | | | | | | | ■ | | | |
| 2KV | 1206(3216) | ■ | | | | | | | | | | | | | | | |
| | 1210(3225) | ■ | | | | | | | | | | | | | | | |
| | 1808(4520) | ■ | | | | | | | | | | | | | | | |
| | 1812(4532) | ■ | | | | | | | | | | | | | | | |
| 3KV | 1808(4520) | ■ | | | | | | | | | | | | | | | |

Part Numbering System

General Capacitors

High Capacitance Capacitors

Super Small Size Capacitors

Medium-High Voltage Capacitors

Array Type Capacitors

Low ESL Capacitors

Reliability Test Condition

Premium Capacitors for Automotive Applications

Packaging Specification

Application Manual for Surface Mounting

Product Lineup (Medium-High Voltage Capacitors-C0G)

| | Part Number | Size L × W (mm) | Capacitance | Rated Voltage (Vdc) | Capacitance Tolerance | Thickness Max. (mm) |
|----|-------------------|-----------------|-------------|---------------------|-----------------------|---------------------|
| 1 | CL10C100JC8NNN □ | 1.60×0.80 | 10pF | 100 | ±5% | 0.90 |
| 2 | CL10C150JC8NNN □ | | 15pF | 100 | ±5% | 0.90 |
| 3 | CL10C330JC8NNN □ | | 33pF | 100 | ±5% | 0.90 |
| 4 | CL10C390JC8NNN □ | | 39pF | 100 | ±5% | 0.90 |
| 5 | CL10C470JC8NNN □ | | 47pF | 100 | ±5% | 0.90 |
| 6 | CL10C560JC8NNN □ | | 560pF | 100 | ±5% | 0.90 |
| 7 | CL10C101JC8NNN □ | | 100pF | 100 | ±5% | 0.90 |
| 8 | CL10C121JC8NNN □ | | 120pF | 100 | ±5% | 0.90 |
| 9 | CL10C151JC8NNN □ | | 150pF | 100 | ±5% | 0.90 |
| 10 | CL10C331JC8NNN □ | | 330pF | 100 | ±5% | 0.90 |
| 11 | CL10C331JD8NNN □ | | 330pF | 200 | ±5% | 0.90 |
| 12 | CL10C331JE8NNN □ | | 330pF | 250 | ±5% | 0.90 |
| 13 | CL10C391JD8NNN □ | | 390pF | 200 | ±5% | 0.90 |
| 14 | CL10C391JE8NNN □ | | 390pF | 250 | ±5% | 0.90 |
| 15 | CL10C471JC8NNN □ | | 470pF | 100 | ±5% | 0.90 |
| 16 | CL10C471JD8NNN □ | | 470pF | 200 | ±5% | 0.90 |
| 17 | CL10C471JE8NNN □ | | 470pF | 250 | ±5% | 0.90 |
| 18 | CL10C561JD8NNN □ | | 560pF | 200 | ±5% | 0.90 |
| 19 | CL10C561JE8NNN □ | | 560pF | 250 | ±5% | 0.90 |
| 20 | CL10C681JC8NNN □ | | 680pF | 100 | ±5% | 0.90 |
| 21 | CL10C681JD8NNN □ | | 680pF | 200 | ±5% | 0.90 |
| 22 | CL10C681JE8NNN □ | | 680pF | 250 | ±5% | 0.90 |
| 23 | CL10C821JC8NNN □ | | 820pF | 100 | ±5% | 0.90 |
| 24 | CL10C102JC8NNN □ | | 1nF | 100 | ±5% | 0.90 |
| 25 | CL10C122JC8NNN □ | | 1.2nF | 100 | ±5% | 0.90 |
| 1 | CL21C100JCANNN □ | 2.00×1.25 | 10pF | 100 | ±5% | 0.75 |
| 2 | CL21C120JCANNN □ | | 12pF | 100 | ±5% | 0.75 |
| 3 | CL21C150JDCNND □ | | 15pF | 200 | ±5% | 0.95 |
| 4 | CL21C150JCANNN □ | | 15pF | 100 | ±5% | 0.75 |
| 5 | CL21C180JDCNND □ | | 18pF | 200 | ±5% | 0.95 |
| 6 | CL21C180JCANNN □ | | 18pF | 100 | ±5% | 0.75 |
| 7 | CL21C220JCANNN □ | | 22pF | 100 | ±5% | 0.75 |
| 8 | CL21C270JCANNN □ | | 27pF | 100 | ±5% | 0.75 |
| 9 | CL21C330JCANNN □ | | 33pF | 100 | ±5% | 0.75 |
| 10 | CL21C330JDCNND □ | | 33pF | 200 | ±5% | 0.95 |
| 11 | CL21C390JDCNND □ | | 39pF | 200 | ±5% | 0.95 |
| 12 | CL21C470JCANNN □ | | 47pF | 100 | ±5% | 0.75 |
| 13 | CL21C470JDCNND □ | | 47pF | 200 | ±5% | 0.95 |
| 14 | CL21C560JCCNND □ | | 56pF | 100 | ±5% | 0.95 |
| 15 | CL21C560JDCNND □ | | 56pF | 200 | ±5% | 0.95 |
| 16 | CL21C680JCANNN □ | | 68pF | 100 | ±5% | 0.75 |
| 17 | CL21C680JDCNND □ | | 68pF | 200 | ±5% | 0.95 |
| 18 | CL21C820JCCNND □ | | 82pF | 100 | ±5% | 0.95 |
| 19 | CL21C101JDCNND □ | | 100pF | 200 | ±5% | 0.95 |
| 20 | CL21C101J ECNNN □ | | 100pF | 250 | ±5% | 0.95 |
| 21 | CL21C101JCANNN □ | | 100pF | 100 | ±5% | 0.75 |
| 22 | CL21C121JDCNND □ | | 120pF | 200 | ±5% | 0.95 |
| 23 | CL21C151JCANNN □ | | 150pF | 100 | ±5% | 0.75 |
| 24 | CL21C221JCANNN □ | | 220pF | 100 | ±5% | 0.75 |
| 25 | CL21C221JDCNND □ | | 220pF | 200 | ±5% | 0.95 |

※ □ mark means packaging code. If you want to learn the code or quantity in detail, please see p80.

Product Lineup (Medium-High Voltage Capacitors-C0G)

| | Part Number | Size L × W (mm) | Capacitance | Rated Voltage (Vdc) | Capacitance Tolerance | Thickness Max. (mm) |
|----|-------------------|-----------------|-------------|---------------------|-----------------------|---------------------|
| 26 | CL21C331JCANNN □ | 2.00×1.25 | 330pF | 100 | ±5% | 0.75 |
| 27 | CL21C471JCCNND □ | | 470pF | 100 | ±5% | 0.95 |
| 28 | CL21C561JCCNND □ | | 560pF | 100 | ±5% | 0.95 |
| 29 | CL21C681JCCNND □ | | 680pF | 100 | ±5% | 0.95 |
| 30 | CL21C102JCFNND □ | | 1nF | 100 | ±5% | 1.35 |
| 31 | CL21C102JDFNND □ | | 1nF | 200 | ±5% | 1.35 |
| 32 | CL21C272JDFNND □ | | 2.7nF | 200 | ±5% | 1.35 |
| 33 | CL21C272JEFNND □ | | 2.7nF | 250 | ±5% | 1.35 |
| 34 | CL21C472JCFNND □ | | 4.7nF | 100 | ±5% | 1.35 |
| 1 | CL31C150JGFNND □ | | 3.20×1.60 | 15pF | 500 | ±5% |
| 2 | CL31C180JGFNND □ | 18pF | | 500 | ±5% | 1.40 |
| 3 | CL31C220JGFNND □ | 22pF | | 500 | ±5% | 1.40 |
| 4 | CL31C220JHNNND □ | 22pF | | 2000 | ±5% | 1.80 |
| 5 | CL31C270JGFNND □ | 27pF | | 500 | ±5% | 1.40 |
| 6 | CL31C330JGFNND □ | 33pF | | 500 | ±5% | 1.40 |
| 7 | CL31C390JGFNND □ | 39pF | | 500 | ±5% | 1.40 |
| 8 | CL31C470JHFNND □ | 47pF | | 630 | ±5% | 1.40 |
| 9 | CL31C470JGFNND □ | 47pF | | 500 | ±5% | 1.40 |
| 10 | CL31C470JHNNND □ | 47pF | | 2000 | ±5% | 1.80 |
| 11 | CL31C560JGFNND □ | 56pF | | 500 | ±5% | 1.40 |
| 12 | CL31C680JCCNND □ | 68pF | | 100 | ±5% | 1.00 |
| 13 | CL31C680JHFNND □ | 68pF | | 630 | ±5% | 1.40 |
| 14 | CL31C680JGFNND □ | 68pF | | 500 | ±5% | 1.40 |
| 15 | CL31C680JIFNND □ | 68pF | | 1000 | ±5% | 1.40 |
| 16 | CL31C820JGFNND □ | 82pF | | 500 | ±5% | 1.40 |
| 17 | CL31C101JGFNND □ | 100pF | | 500 | ±5% | 1.40 |
| 18 | CL31C101JHFNND □ | 100pF | | 630 | ±5% | 1.40 |
| 19 | CL31C101JIFNND □ | 100pF | | 1000 | ±5% | 1.40 |
| 20 | CL31C101JHNNND □ | 100pF | | 2000 | ±5% | 1.80 |
| 21 | CL31C121JGFNND □ | 120pF | | 500 | ±5% | 1.40 |
| 22 | CL31C151JGFNND □ | 150pF | | 500 | ±5% | 1.40 |
| 23 | CL31C181JGFNND □ | 180pF | | 500 | ±5% | 1.40 |
| 24 | CL31C221JGFNND □ | 220pF | | 500 | ±5% | 1.40 |
| 25 | CL31C271JGFNND □ | 270pF | | 500 | ±5% | 1.40 |
| 26 | CL31C271JCCNND □ | 270pF | | 100 | ±5% | 1.00 |
| 27 | CL31C331JGFNND □ | 330pF | | 500 | ±5% | 1.40 |
| 28 | CL31C331JHNNND □ | 330pF | | 1000 | ±5% | 1.80 |
| 29 | CL31C391JCCNND □ | 390pF | | 100 | ±5% | 1.00 |
| 30 | CL31C471JGFNND □ | 470pF | | 500 | ±5% | 1.40 |
| 31 | CL31C561JCCNND □ | 560pF | | 100 | ±5% | 1.00 |
| 32 | CL31C561JGFNND □ | 560pF | | 500 | ±5% | 1.40 |
| 33 | CL31C681JGFNND □ | 680pF | | 500 | ±5% | 1.80 |
| 34 | CL31C102JCCNND □ | 1nF | | 100 | ±5% | 1.00 |
| 35 | CL31C102JGHNNND □ | 1nF | | 500 | ±5% | 1.80 |
| 36 | CL31C152JCCNND □ | 1.5nF | | 100 | ±5% | 1.00 |
| 37 | CL31C222JCCNND □ | 2.2nF | | 100 | ±5% | 1.00 |
| 38 | CL31C332JGHNNND □ | 3.3nF | | 500 | ±5% | 1.80 |
| 39 | CL31C332JHNNND □ | 3.3nF | | 630 | ±5% | 1.80 |
| 40 | CL31C392JCHNNND □ | 3.9nF | | 100 | ±5% | 1.80 |
| 41 | CL31C822JHNNND □ | 8.2nF | | 200 | ±5% | 1.80 |

※ □ mark means packaging code. If you want to learn the code or quantity in detail, please see p80.

Part Numbering System

General Capacitors

High Capacitance Capacitors

Super Small Size Capacitors

Medium-High Voltage Capacitors

Array Type Capacitors

Low ESL Capacitors

Reliability Test Condition

Premium Capacitors for Automotive Applications

Packaging Specification

Application Manual for Surface Mounting

Product Lineup (Medium-High Voltage Capacitors-C0G)

| | Part Number | Size L × W (mm) | Capacitance | Rated Voltage (Vdc) | Capacitance Tolerance | Thickness Max. (mm) |
|----|-------------------|-----------------|-------------|---------------------|-----------------------|---------------------|
| 42 | CL31C822JEHNNN □ | 3.20×1.60 | 8.2nF | 250 | ±5% | 1.80 |
| 43 | CL31C183JCHNNN □ | | 18nF | 100 | ±5% | 1.80 |
| 1 | CL32C101JFNNN □ | 3.20×2.50 | 100pF | 2000 | ±5% | 1.45 |
| 2 | CL32C471JJJNNN □ | | 470pF | 2000 | ±5% | 2.70 |
| 3 | CL32C821JIIJNNN □ | | 820pF | 1000 | ±5% | 2.70 |
| 4 | CL32C103JGJNNN □ | | 10nF | 500 | ±5% | 2.70 |
| 5 | CL32C103JHJNNN □ | | 10nF | 630 | ±5% | 2.70 |
| 6 | CL32C273JDJNNN □ | | 27nF | 200 | ±5% | 2.70 |
| 7 | CL32C273JEJNNN □ | | 27nF | 250 | ±5% | 2.70 |
| 8 | CL32C563JCJNNN □ | | 56nF | 100 | ±5% | 2.70 |
| 1 | CL42C100JFNNN □ | 4.50×2.00 | 10pF | 3000 | ±5% | 1.45 |
| 2 | CL42C151JKINNN □ | | 150pF | 3000 | ±5% | 2.20 |
| 3 | CL42C221JJHNNN □ | | 220pF | 2000 | ±5% | 1.80 |
| 1 | CL43C391JKJNNN □ | 4.50×3.20 | 390pF | 2000 | ±5% | 2.70 |
| 2 | CL43C102JIIHNNN □ | | 1.0nF | 1000 | ±5% | 1.80 |
| 3 | CL43C122JIIJNNN □ | | 1.2nF | 1000 | ±5% | 2.20 |
| 4 | CL43C182JIIJNNN □ | | 1.8nF | 1000 | ±5% | 2.70 |
| 5 | CL43C182JJJNNN □ | | 1.8nF | 2000 | ±5% | 2.70 |
| 6 | CL43C223JGJNNN □ | | 22nF | 500 | ±5% | 2.70 |
| 7 | CL43C223JHJNNN □ | | 22nF | 630 | ±5% | 2.70 |
| 8 | CL43C473JDJNNN □ | | 47nF | 200 | ±5% | 2.70 |
| 9 | CL43C473JEJNNN □ | | 47nF | 250 | ±5% | 2.70 |
| 10 | CL43C563JCJNNN □ | | 56nF | 100 | ±5% | 2.70 |
| 1 | CL55C102JJJNNN □ | 5.70×5.00 | 1nF | 2000 | ±5% | 2.70 |
| 2 | CL55C102JKJNNN □ | | 1nF | 3000 | ±5% | 2.70 |
| 3 | CL55C362JIIJNNN □ | | 3.3nF | 1000 | ±5% | 2.70 |
| 4 | CL55C223JGJNNN □ | | 22nF | 500 | ±5% | 2.70 |
| 5 | CL55C223JHJNNN □ | | 22nF | 630 | ±5% | 2.70 |
| 6 | CL55C473JDJNNN □ | | 47nF | 200 | ±5% | 2.70 |
| 7 | CL55C473JEJNNN □ | | 47nF | 250 | ±5% | 2.70 |
| 8 | CL55C683JCJNNN □ | | 68nF | 100 | ±5% | 2.70 |

※ □mark means packaging code. If you want to learn the code or quantity in detail, please see p80.

Product Lineup (Medium-High Voltage Capacitors-X7R)

| | Part Number | Size L × W (mm) | Capacitance | Rated Voltage (Vdc) | Capacitance Tolerance | Thickness Max. (mm) |
|----|------------------|-----------------|-------------|---------------------|-----------------------|---------------------|
| 1 | CL10B102KC8NNN □ | 1.60×0.80 | 1nF | 100 | ±10% | 0.90 |
| 2 | CL10B472KC8NNN □ | | 4.7nF | 100 | ±10% | 0.90 |
| 3 | CL10B103KC8NNN □ | | 10nF | 100 | ±10% | 0.90 |
| 1 | CL21B221KDCNNN □ | 2.00×1.25 | 220pF | 200 | ±10% | 0.95 |
| 2 | CL21B221KCANNN □ | | 220pF | 100 | ±10% | 0.75 |
| 3 | CL21B331KDCNNN □ | | 330pF | 200 | ±10% | 0.95 |
| 4 | CL21B471KCANNN □ | | 470pF | 100 | ±10% | 0.75 |
| 5 | CL21B102KDCNNN □ | | 1nF | 200 | ±10% | 0.95 |
| 6 | CL21B102KCANNN □ | | 1nF | 100 | ±10% | 0.75 |
| 7 | CL21B222KDCNNN □ | | 2.2nF | 200 | ±10% | 0.95 |
| 8 | CL21B222KCANNN □ | | 2.2nF | 100 | ±10% | 0.75 |
| 9 | CL21B332KCANNN □ | | 3.3nF | 100 | ±10% | 0.75 |
| 10 | CL21B472KDCNNN □ | | 4.7nF | 200 | ±10% | 0.95 |
| 11 | CL21B472KCANNN □ | | 4.7nF | 100 | ±10% | 0.75 |
| 12 | CL21B682KCANNN □ | | 6.8nF | 100 | ±10% | 0.75 |
| 13 | CL21B103KDCNNN □ | | 10nF | 200 | ±10% | 0.95 |
| 14 | CL21B103KCANNN □ | | 10nF | 100 | ±10% | 0.75 |
| 15 | CL21B153KEFNNN □ | | 15nF | 250 | ±10% | 1.35 |
| 16 | CL21B153KDFNNN □ | | 15nF | 200 | ±10% | 1.35 |
| 17 | CL21B153KCCNNN □ | | 15nF | 100 | ±10% | 0.95 |
| 18 | CL21B223KCFNNN □ | | 22nF | 100 | ±10% | 1.35 |
| 19 | CL21B473KCFNNN □ | | 47nF | 100 | ±10% | 1.35 |
| 20 | CL21B683KCFNNN □ | | 68nF | 100 | ±10% | 1.35 |
| 21 | CL21B104KCFNNN □ | | 100nF | 100 | ±10% | 1.35 |
| 22 | CL21B154KCFNNN □ | | 150nF | 100 | ±10% | 1.35 |
| 23 | CL21B224KCFNNN □ | | 220nF | 100 | ±10% | 1.35 |
| 1 | CL31B221KGFNNN □ | 3.20×1.60 | 220pF | 500 | ±10% | 1.40 |
| 2 | CL31B471KGFNNN □ | | 470pF | 500 | ±10% | 1.40 |
| 3 | CL31B471KDCNNN □ | | 470pF | 200 | ±10% | 1.00 |
| 4 | CL31B102KJHNNN □ | | 1nF | 2000 | ±10% | 1.80 |
| 5 | CL31B102KIFNNN □ | | 1nF | 1000 | ±10% | 1.40 |
| 6 | CL31B102KGFNNN □ | | 1nF | 500 | ±10% | 1.40 |
| 7 | CL31B102KHFNNN □ | | 1nF | 630 | ±10% | 1.40 |
| 8 | CL31B152KGFNNN □ | | 1.5nF | 500 | ±10% | 1.40 |
| 9 | CL31B152KJHNNN □ | | 1.5nF | 2000 | ±10% | 1.80 |
| 10 | CL31B222KIFNNN □ | | 2.2nF | 1000 | ±10% | 1.40 |
| 11 | CL31B222KDCNNN □ | | 2.2nF | 200 | ±10% | 1.00 |
| 12 | CL31B222KGFNNN □ | | 2.2nF | 500 | ±10% | 1.40 |
| 13 | CL31B222KJHNNN □ | | 2.2nF | 2000 | ±10% | 1.80 |
| 14 | CL31B332KGFNNN □ | | 3.3nF | 500 | ±10% | 1.40 |
| 15 | CL31B332KIFNNN □ | | 3.3nF | 1000 | ±10% | 1.40 |
| 16 | CL31B472KGFNNN □ | | 4.7nF | 500 | ±10% | 1.40 |

※ □mark means packaging code. If you want to learn the code or quantity in detail, please see p80.

Part Numbering System

General Capacitors

High Capacitance Capacitors

Super Small Size Capacitors

Medium-High Voltage Capacitors

Array Type Capacitors

Low ESL Capacitors

Reliability Test Condition

Premium Capacitors for Automotive Applications

Packaging Specification

Application Manual for Surface Mounting

Product Lineup (Medium-High Voltage Capacitors-X7R)

| | Part Number | Size L × W (mm) | Capacitance | Rated Voltage (Vdc) | Capacitance Tolerance | Thickness Max. (mm) | |
|----|-------------------|-----------------|-------------|---------------------|-----------------------|---------------------|------|
| 17 | CL31B472KDCNNN □ | 3.20×1.60 | 4.7nF | 200 | ±10% | 1.00 | |
| 18 | CL31B682KGFNNN □ | | 6.8nF | 500 | ±10% | 1.40 | |
| 19 | CL31B103KHFNNN □ | | 10nF | 630 | ±10% | 1.40 | |
| 20 | CL31B103KGFNNN □ | | 10nF | 500 | ±10% | 1.40 | |
| 21 | CL31B103KFCNNN □ | | 10nF | 350 | ±10% | 1.00 | |
| 22 | CL31B153KDCNNN □ | | 15nF | 200 | ±10% | 1.00 | |
| 23 | CL31B153KFCNNN □ | | 15nF | 350 | ±10% | 1.00 | |
| 24 | CL31B153KCCNNN □ | | 15nF | 100 | ±10% | 1.00 | |
| 25 | CL31B153KGFNNN □ | | 15nF | 500 | ±10% | 1.40 | |
| 26 | CL31B153KHFNNN □ | | 15nF | 630 | ±10% | 1.40 | |
| 27 | CL31B223KDCNNN □ | | 22nF | 200 | ±10% | 1.00 | |
| 28 | CL31B223KCCNNN □ | | 22nF | 100 | ±10% | 1.00 | |
| 29 | CL31B223KFCNNN □ | | 22nF | 350 | ±10% | 1.00 | |
| 30 | CL31B223KGHNNN □ | | 22nF | 500 | ±10% | 1.80 | |
| 31 | CL31B223KHHNNN □ | | 22nF | 630 | ±10% | 1.80 | |
| 32 | CL31B333KDFNNN □ | | 33nF | 200 | ±10% | 1.40 | |
| 33 | CL31B333KFESNN □ | | 33nF | 350 | ±10% | 1.25 | |
| 34 | CL31B333KCCNNN □ | | 33nF | 100 | ±10% | 1.00 | |
| 35 | CL31B333KGHNNN □ | | 33nF | 500 | ±10% | 1.80 | |
| 36 | CL31B333KHHNNN □ | | 33nF | 630 | ±10% | 1.80 | |
| 37 | CL31B473KDFNNN □ | | 47nF | 200 | ±10% | 1.40 | |
| 38 | CL31B473KFHSNN □ | | 47nF | 350 | ±10% | 1.80 | |
| 39 | CL31B473KCCNNN □ | | 47nF | 100 | ±10% | 1.00 | |
| 40 | CL31B473KEHNNN □ | | 47nF | 250 | ±10% | 1.80 | |
| 41 | CL31B683KEHNNN □ | | 68nF | 250 | ±10% | 1.80 | |
| 42 | CL31B104KDHNNN □ | | 100nF | 200 | ±10% | 1.80 | |
| 43 | CL31B104KCFNNN □ | | 100nF | 100 | ±10% | 1.40 | |
| 44 | CL31B104KEHNNN □ | | 100nF | 250 | ±10% | 1.80 | |
| 45 | CL31B154KCHNNN □ | | 150nF | 100 | ±10% | 1.80 | |
| 46 | CL31B105KCHNNN □ | | 1μF | 100 | ±10% | 1.80 | |
| 47 | CL31B155KCHNNN □ | | 1.5μF | 100 | ±10% | 1.80 | |
| 48 | CL31B225KCHNNN □ | | 2.2μF | 100 | ±10% | 1.80 | |
| 1 | CL32B102KJFNNN □ | | 3.20×2.50 | 1nF | 2000 | ±10% | 1.45 |
| 2 | CL32B472KHFNNN □ | | | 4.7nF | 630 | ±10% | 1.45 |
| 3 | CL32B472KIFNNN □ | | | 4.7nF | 1000 | ±10% | 1.45 |
| 4 | CL32B682KIFNNN □ | | | 6.8nF | 1000 | ±10% | 1.45 |
| 5 | CL32B103KCFNNN □ | | | 10nF | 100 | ±10% | 1.45 |
| 6 | CL32B153KGFNNN □ | | | 15nF | 500 | ±10% | 1.45 |
| 7 | CL32B223KGFNNN □ | | | 22nF | 500 | ±10% | 1.45 |
| 8 | CL32B333KHHNNN □ | | | 33nF | 630 | ±10% | 1.80 |
| 9 | CL32B333KGHNNN □ | | | 33nF | 500 | ±10% | 1.80 |
| 10 | CL32B473KHHNNN □ | | | 47nF | 630 | ±10% | 1.80 |
| 11 | CL32B473KDHNNN □ | | 3.20×2.50 | 47nF | 200 | ±10% | 1.80 |
| 12 | CL32B473KGHNNN □ | | | 47nF | 500 | ±10% | 1.80 |
| 13 | CL32B683KDINNN □ | | | 68nF | 200 | ±10% | 2.20 |
| 14 | CL32B104KE JNNN □ | | | 100nF | 250 | ±10% | 2.70 |
| 15 | CL32B104KDINNN □ | | | 100nF | 200 | ±10% | 2.20 |
| 16 | CL32B154KCFNNN □ | | | 150nF | 100 | ±10% | 1.45 |
| 17 | CL32B154KDJNNN □ | 150nF | | 200 | ±10% | 2.70 | |
| 18 | CL32B154KJNNN □ | 150nF | | 250 | ±10% | 2.70 | |
| 19 | CL32B224KCHNNN □ | 220nF | | 100 | ±10% | 1.80 | |
| 20 | CL32B224KDJNNN □ | 220nF | | 200 | ±10% | 2.70 | |
| 21 | CL32B224KEJNNN □ | 220nF | | 250 | ±10% | 2.70 | |
| 22 | CL32B334KCHNNN □ | 330nF | | 100 | ±10% | 1.80 | |
| 23 | CL32B474KCIINN □ | 470nF | | 100 | ±10% | 2.20 | |
| 24 | CL32B105KCIINN □ | 1μF | | 100 | ±10% | 2.70 | |
| 25 | CL32B155KCHNNN □ | 1.5μF | | 100 | ±10% | 1.80 | |
| 26 | CL32B225KCIINN □ | 2.2μF | | 100 | ±10% | 2.70 | |
| 1 | CL43B102KJFNNN □ | 4.50×3.20 | | 1nF | 2000 | ±10% | 1.45 |
| 2 | CL43B152KJFNNN □ | | | 1.5nF | 2000 | ±10% | 1.45 |
| 3 | CL43B222KIFNNN □ | | | 2.2nF | 1000 | ±10% | 1.45 |
| 4 | CL43B222KJFNNN □ | | | 2.2nF | 2000 | ±10% | 1.45 |
| 5 | CL43B332KJFNNN □ | | | 3.3nF | 2000 | ±10% | 1.45 |
| 6 | CL43B103KIFNNN □ | | | 10nF | 1000 | ±10% | 1.45 |
| 7 | CL43B333KIJNNN □ | | | 33nF | 1000 | ±10% | 2.70 |
| 8 | CL43B473KGFNNN □ | | | 47nF | 500 | ±10% | 1.45 |
| 9 | CL43B473KHFNNN □ | | | 47nF | 630 | ±10% | 1.45 |
| 10 | CL43B473KIJNNN □ | | | 47nF | 1000 | ±10% | 2.70 |
| 11 | CL43B104KGIINN □ | | 100nF | 500 | ±10% | 2.20 | |
| 12 | CL43B104KDFNNN □ | | 100nF | 200 | ±10% | 1.45 | |
| 13 | CL43B104KHINNN □ | | 100nF | 630 | ±10% | 2.20 | |
| 14 | CL43B224KCFNNN □ | | 220nF | 100 | ±10% | 1.45 | |
| 15 | CL43B334KCFNNN □ | | 330nF | 100 | ±10% | 1.45 | |
| 16 | CL43B474KEJNNN □ | | 470nF | 250 | ±10% | 2.70 | |
| 17 | CL43B474KCHNNN □ | | 470nF | 100 | ±10% | 1.80 | |
| 18 | CL43B474KDJNNN □ | | 470nF | 200 | ±10% | 2.70 | |
| 19 | CL43B105KCIINN □ | | 1μF | 100 | ±10% | 2.70 | |
| 1 | CL55B103KJHNNN □ | 5.70×5.00 | 10nF | 2000 | ±10% | 1.80 | |
| 2 | CL55B473KIINNN □ | | 47nF | 1000 | ±10% | 2.20 | |
| 3 | CL55B224KJNNN □ | | 220nF | 500 | ±10% | 2.70 | |
| 4 | CL55B224KHJNNN □ | | 220nF | 630 | ±10% | 2.70 | |
| 5 | CL55B105KCHNNN □ | | 1μF | 100 | ±10% | 1.80 | |
| 6 | CL55B105KDJNNN □ | | 1μF | 200 | ±10% | 2.70 | |
| 7 | CL55B105KEJNNN □ | | 1μF | 250 | ±10% | 2.70 | |
| 8 | CL55B475KJNNN □ | | 4.7uF | 100 | ±10% | 2.70 | |

※ □ mark means packaging code. If you want to learn the code or quantity in detail, please see p80.

Product Lineup (Medium-High Voltage Capacitors-X7R)

| | Part Number | Size L × W (mm) | Capacitance | Rated Voltage (Vdc) | Capacitance Tolerance | Thickness Max. (mm) | |
|----|-------------------|-----------------|-------------|---------------------|-----------------------|---------------------|------|
| 11 | CL32B473KDHNNN □ | 3.20×2.50 | 47nF | 200 | ±10% | 1.80 | |
| 12 | CL32B473KGHNNN □ | | 47nF | 500 | ±10% | 1.80 | |
| 13 | CL32B683KDINNN □ | | 68nF | 200 | ±10% | 2.20 | |
| 14 | CL32B104KE JNNN □ | | 100nF | 250 | ±10% | 2.70 | |
| 15 | CL32B104KDINNN □ | | 100nF | 200 | ±10% | 2.20 | |
| 16 | CL32B154KCFNNN □ | | 150nF | 100 | ±10% | 1.45 | |
| 17 | CL32B154KDJNNN □ | | 150nF | 200 | ±10% | 2.70 | |
| 18 | CL32B154KJNNN □ | | 150nF | 250 | ±10% | 2.70 | |
| 19 | CL32B224KCHNNN □ | | 220nF | 100 | ±10% | 1.80 | |
| 20 | CL32B224KDJNNN □ | | 220nF | 200 | ±10% | 2.70 | |
| 21 | CL32B224KEJNNN □ | | 220nF | 250 | ±10% | 2.70 | |
| 22 | CL32B334KCHNNN □ | | 330nF | 100 | ±10% | 1.80 | |
| 23 | CL32B474KCIINN □ | | 470nF | 100 | ±10% | 2.20 | |
| 24 | CL32B105KCIINN □ | | 1μF | 100 | ±10% | 2.70 | |
| 25 | CL32B155KCHNNN □ | | 1.5μF | 100 | ±10% | 1.80 | |
| 26 | CL32B225KCIINN □ | | 2.2μF | 100 | ±10% | 2.70 | |
| 1 | CL43B102KJFNNN □ | | 4.50×3.20 | 1nF | 2000 | ±10% | 1.45 |
| 2 | CL43B152KJFNNN □ | | | 1.5nF | 2000 | ±10% | 1.45 |
| 3 | CL43B222KIFNNN □ | | | 2.2nF | 1000 | ±10% | 1.45 |
| 4 | CL43B222KJFNNN □ | | | 2.2nF | 2000 | ±10% | 1.45 |
| 5 | CL43B332KJFNNN □ | | | 3.3nF | 2000 | ±10% | 1.45 |
| 6 | CL43B103KIFNNN □ | | | 10nF | 1000 | ±10% | 1.45 |
| 7 | CL43B333KIJNNN □ | | | 33nF | 1000 | ±10% | 2.70 |
| 8 | CL43B473KGFNNN □ | | | 47nF | 500 | ±10% | 1.45 |
| 9 | CL43B473KHFNNN □ | | | 47nF | 630 | ±10% | 1.45 |
| 10 | CL43B473KIJNNN □ | | | 47nF | 1000 | ±10% | 2.70 |
| 11 | CL43B104KGIINN □ | 100nF | | 500 | ±10% | 2.20 | |
| 12 | CL43B104KDFNNN □ | 100nF | | 200 | ±10% | 1.45 | |
| 13 | CL43B104KHINNN □ | 100nF | | 630 | ±10% | 2.20 | |
| 14 | CL43B224KCFNNN □ | 220nF | | 100 | ±10% | 1.45 | |
| 15 | CL43B334KCFNNN □ | 330nF | | 100 | ±10% | 1.45 | |
| 16 | CL43B474KEJNNN □ | 470nF | | 250 | ±10% | 2.70 | |
| 17 | CL43B474KCHNNN □ | 470nF | | 100 | ±10% | 1.80 | |
| 18 | CL43B474KDJNNN □ | 470nF | | 200 | ±10% | 2.70 | |
| 19 | CL43B105KCIINN □ | 1μF | | 100 | ±10% | 2.70 | |
| 1 | CL55B103KJHNNN □ | 5.70×5.00 | 10nF | 2000 | ±10% | 1.80 | |
| 2 | CL55B473KIINNN □ | | 47nF | 1000 | ±10% | 2.20 | |
| 3 | CL55B224KJNNN □ | | 220nF | 500 | ±10% | 2.70 | |
| 4 | CL55B224KHJNNN □ | | 220nF | 630 | ±10% | 2.70 | |
| 5 | CL55B105KCHNNN □ | | 1μF | 100 | ±10% | 1.80 | |
| 6 | CL55B105KDJNNN □ | | 1μF | 200 | ±10% | 2.70 | |
| 7 | CL55B105KEJNNN □ | | 1μF | 250 | ±10% | 2.70 | |
| 8 | CL55B475KJNNN □ | | 4.7uF | 100 | ±10% | 2.70 | |

※ □ mark means packaging code. If you want to learn the code or quantity in detail, please see p80.

- Part Numbering System
- General Capacitors
- High Capacitance Capacitors
- Super Small Size Capacitors
- Medium-High Voltage Capacitors
- Array Type Capacitors
- Low ESL Capacitors
- Reliability Test Condition
- Premium Capacitors for Automotive Applications
- Packaging Specification
- Application Manual for Surface Mounting

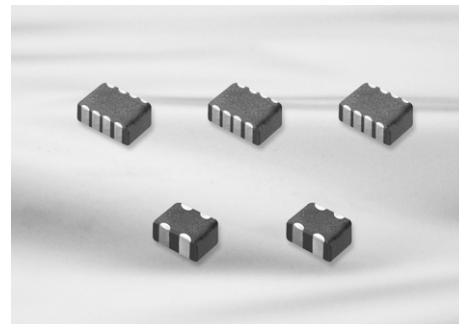

Feature

- Reduction in required space (more than 50%)
- Reduction in cost and time for replacement of PCB
- Reduction in amount of solder joints
- Easier PCB design
- Reduced waste from tape and reel packaging process
- It protect EMI bypassing digital signal line nose

Application

- A bypass for digital and analog signal line noise generated by telecommunication equipment and other common electronic circuits
- ※ For using special purpose like Military, Medical, Aviation, Automobile device should be following a special specification.

Structure and Dimensions

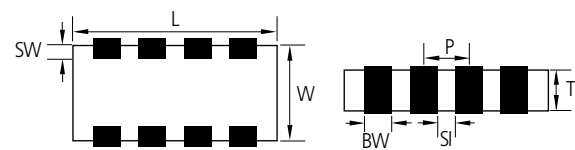

| Code | EIA Code | Dimension(mm) | | | | | |
|------|----------|---------------|-----------|--|----------|-----------|----------|
| | | L | W | T | BW | SW | P |
| A | 0504 | 1.37±0.15 | 1.0±0.15 | 0.35±0.05 0.50±0.05 0.60±0.06 0.80±0.08 | 0.36±0.1 | 0.2±0.1 | 0.64±0.1 |
| A | 0805 | 2.0±0.15 | 1.25±0.15 | 0.85±0.1 | 0.5±0.2 | 0.25±0.15 | 1.0±0.1 |
| B | 0805 | 2.0±0.15 | 1.25±0.15 | 0.85±0.1 | 0.25±0.1 | 0.25±0.15 | 0.5±0.1 |
| B | 1206 | 3.2±0.15 | 1.6±0.15 | 0.85±0.15 | 0.4±0.2 | 0.3±0.15 | 0.8±0.2 |

Structure and Control Code

■ A : ARRAY(2-element)

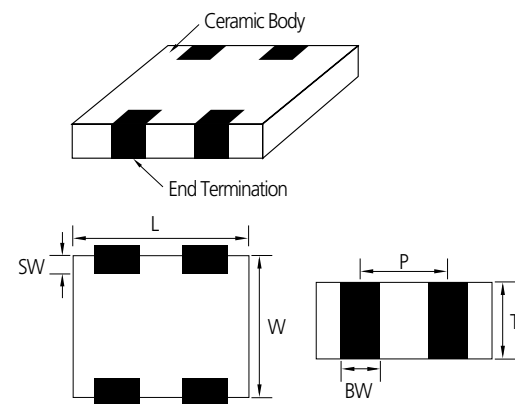

■ B : ARRAY(4-element)

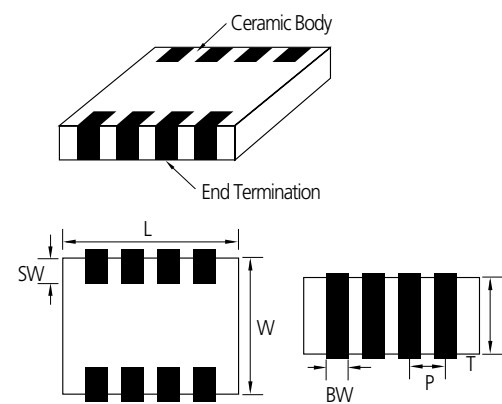

Array Type Capacitors Table (C0G, X5R, X7R, Y5V)

| TC | Size(mm) | Type | Vr(V) | Tmax (mm) | Capacitance (pF) | | | | | | | | | | | | | |
|------------|------------|---------------------|-------|---------------------|---------------------|---------------------|---------------------|---------------------|-----|-----|-----|-----|-----|------|------|--|--|--|
| | | | | | 10 | 22 | 27 | 47 | 100 | 470 | | | | | | | | |
| C0G | 0504(1410) | 2-element | 25 | | [Capacitance Range] | | | | | | | | | | | | | |
| | 1206(3216) | 4-element | 50 | | [Capacitance Range] | | | | | | | | | | | | | |
| TC | Size(mm) | Type | Vr(V) | Tmax (mm) | Capacitance (nF) | | | | | | | | | | | | | |
| | | | | | 1 | 2.2 | 4.7 | 10 | 22 | 47 | 100 | 220 | 470 | 1000 | 2200 | | | |
| X5R | 0504(1410) | 2-element | 4 | 0.5 | [Capacitance Range] | | | | | | | | | | | | | |
| | | | | | 6.3 | [Capacitance Range] | | | | | | | | | | | | |
| | | | | | | 10 | [Capacitance Range] | | | | | | | | | | | |
| | | | 6.3 | 0.88 | | | [Capacitance Range] | | | | | | | | | | | |
| | | | | | 0.66 | | [Capacitance Range] | | | | | | | | | | | |
| | | | | | | 0.55 | [Capacitance Range] | | | | | | | | | | | |
| | | | | 10 | | | 0.88 | [Capacitance Range] | | | | | | | | | | |
| | | | | | 0.66 | | | [Capacitance Range] | | | | | | | | | | |
| | | | | | | 0.55 | | [Capacitance Range] | | | | | | | | | | |
| | | | 16 | 0.88 | | | [Capacitance Range] | | | | | | | | | | | |
| | | | | | 0.66 | | [Capacitance Range] | | | | | | | | | | | |
| | | | | | | 0.55 | [Capacitance Range] | | | | | | | | | | | |
| 25 | 0.88 | [Capacitance Range] | | | | | | | | | | | | | | | | |
| | | 0.66 | | [Capacitance Range] | | | | | | | | | | | | | | |
| | | | | 0.55 | [Capacitance Range] | | | | | | | | | | | | | |
| 0805(2012) | 2-element | | 6.3 | | | [Capacitance Range] | | | | | | | | | | | | |
| | | 10 | 0.95 | | [Capacitance Range] | | | | | | | | | | | | | |
| | | 16 | | [Capacitance Range] | | | | | | | | | | | | | | |
| X7R | 0805(2012) | 4-element | 10 | 0.95 | [Capacitance Range] | | | | | | | | | | | | | |
| | | | 16 | | [Capacitance Range] | | | | | | | | | | | | | |
| | 1206(3216) | 4-element | 16 | | [Capacitance Range] | | | | | | | | | | | | | |
| | | | 25 | 0.95 | [Capacitance Range] | | | | | | | | | | | | | |
| Y5V | 1206(3216) | 4-element | 25 | 1.0 | [Capacitance Range] | | | | | | | | | | | | | |
| | | | 50 | | [Capacitance Range] | | | | | | | | | | | | | |

Part Numbering System

General Capacitors

High Capacitance Capacitors

Super Small Size Capacitors

Medium-High Voltage Capacitors

Array Type Capacitors

Low ESL Capacitors

Reliability Test Condition

Premium Capacitors for Automotive Applications

Packaging Specification

Application Manual for Surface Mounting

Product Lineup (Array Type Capacitors)

| | Part Number | Element Type | Size L×W (mm) | Capacitance | Rated Voltage (Vdc) | Capacitance Tolerance | Thickness Max. (mm) |
|----|--------------------|--------------|---------------|-------------|---------------------|-----------------------|---------------------|
| 1 | CL14C270KA6NAN □ | 2-Array | 1.40×1.00 | 27pF | 25 | +10% | 0.66 |
| 1 | CL31C100 JBCNBN □ | 4-Array | 3.20×1.60 | 10pF | 50 | ±5% | 1.0 |
| 2 | CL31C150 JBCNBN □ | | | 15pF | 50 | ±5% | 1.0 |
| 3 | CL31C220J BCNBN □ | | | 22pF | 50 | ±5% | 1.0 |
| 4 | CL31C270 JBCNBN □ | | | 27pF | 50 | ±5% | 1.0 |
| 5 | CL31C330KBCNBN □ | | | 33pF | 50 | ±10% | 1.0 |
| 6 | CL31C390KBCNBN □ | | | 39pF | 50 | ±10% | 1.0 |
| 7 | CL31C680J BCNBN □ | | | 68pF | 50 | ±5% | 1.0 |
| 8 | CL31C820 JBCNBN □ | | | 82pF | 50 | ±5% | 1.0 |
| 9 | CL31C101JB CNBN □ | | | 100pF | 50 | ±5% | 1.0 |
| 10 | CL31C151KBCNBN □ | | | 150pF | 50 | ±10% | 1.0 |
| 11 | CL31C181JB CNBN □ | | | 180pF | 50 | ±5% | 1.0 |
| 12 | CL31C331J B CNBN □ | | | 330pF | 50 | ±5% | 1.0 |
| 13 | CL31C471JB CNBN □ | | | 470pF | 50 | ±5% | 1.0 |
| 1 | CL21B471KBCNBN □ | 4-Array | 2.00×1.25 | 470pF | 50 | ±10% | 0.95 |
| 2 | CL21B104KOCNBN □ | 4-Array | 2.00×1.25 | 100nF | 16 | ±10% | 0.95 |
| 3 | CL21B104MPCNBN □ | | | 100nF | 10 | ±20% | 0.95 |
| 1 | CL31B102MBCNBN □ | | | 4-Array | 3.20×1.60 | 1nF | 50 |
| 2 | CL31B103MBCNBN □ | 10nF | 50 | | | ±20% | 1.00 |
| 3 | CL31B153KBCNBN □ | 15nF | 50 | | | ±10% | 1.00 |
| 4 | CL31B473KACNBN □ | 47nF | 25 | | | ±10% | 1.00 |
| 5 | CL31B104KACNBN □ | 100nF | 25 | | | ±10% | 1.00 |
| 6 | CL31B104KOCNBN □ | 100nF | 16 | | | ±10% | 1.00 |
| 1 | CL09A104KQ4SAN □ | 2-Array | 0.90×0.60 | 100nF | 6.3 | ±10% | 0.5 |
| 2 | CL09A104KP4SAN □ | 2-Array | 1.40×1.00 | 100nF | 10 | ±10% | 0.5 |
| 1 | CL14A104KA6NAN □ | | | 100nF | 25 | ±10% | 0.66 |
| 2 | CL14A104KO6NAN □ | | | 100nF | 16 | ±10% | 0.66 |
| 3 | CL14A104KP6NAN □ | 2-Array | 1.40×1.00 | 100nF | 10 | ±10% | 0.66 |
| 1 | CL14A105MA5NAN □ | | | 1μF | 25 | ±20% | 0.55 |
| 2 | CL14A105KP8NAN □ | | | 1μF | 10 | ±20% | 0.88 |
| 3 | CL14A105MO3NAN □ | | | 1μF | 16 | ±20% | 0.4 |
| 4 | CL14A105MO8NAN □ | | | 1μF | 16 | ±20% | 0.88 |
| 5 | CL14A105MP3NAN □ | | | 1μF | 10 | ±20% | 0.4 |
| 6 | CL14A105MP5NAN □ | | | 1μF | 10 | ±20% | 0.55 |
| 7 | CL14A225KP8NAN □ | | | 2.2μF | 10 | ±10% | 0.88 |
| 8 | CL14A225KQ8NAN □ | | | 2.2μF | 6.3 | ±10% | 0.88 |
| 9 | CL14A105MO5NAN □ | 1μF | 16 | ±10% | 0.55 | | |
| 1 | CL21A105KOCNAN □ | 2-Array | 2.00×1.25 | 1μF | 16 | ±20% | 0.95 |
| 2 | CL21A105MPCNAN □ | 2-Array | 1.40×1.00 | 1μF | 10 | ±10% | 0.88 |
| 1 | CL31F473ZB CNBN □ | 4-Array | 3.20×1.60 | 47nF | 50 | 80%/-20% | 1.0 |
| 2 | CL31F104ZACNBN □ | | | 100nF | 25 | 80%/-20% | 1.0 |

※ □ mark means packaging code. If you want to learn the code or quantity in detail, please see p80.

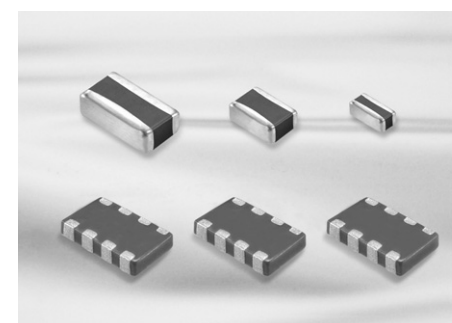

Feature

- Low ESL, good for noise reduction for high frequency
- Highly reliable tolerance and high speed automatic chip placement on PCBs
- Highly reliable performance
- Highly resistant termination metal
- Tape & reel for surface mount assembly

Application

- High Speed Microprocessor
- High Frequency Digital Equipment
- ※ For using special purpose like Military, Medical, Aviation, Automobile device should be following a special specification.

LICC(Low Inductance chip capacitors)

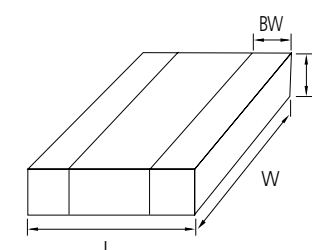

| Code | EIA Code | Dimension(mm) | | | |
|------|----------|---------------|----------|---------------|-----------|
| | | L | W | T | BW |
| L5 | 0204 | 0.52±0.05 | 1.0±0.05 | 0.3±0.05 | 0.18±0.08 |
| 01 | 0306 | 0.8±0.15 | 1.6±0.2 | 0.5+0.05/-0.1 | 0.25±0.15 |

SLIC(Super Low Inductance capacitors)

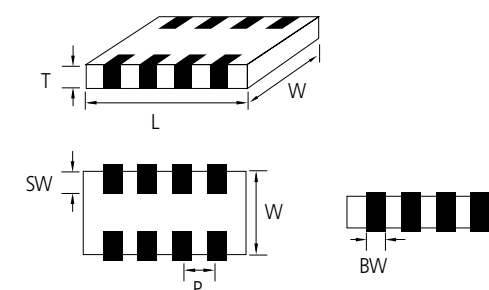

| Code | EIA Code | Dimension(mm) | | | | | |
|------|----------|---------------|----------|---------------|----------|----------|---------|
| | | L | W | T | BW | SW | P |
| 10 | 0603 | 1.6±0.1 | 0.8±0.1 | 0.5/+0.05-0.1 | 0.25±0.1 | 0.15±0.1 | 0.4±0.1 |
| 21 | 0805 | 2.0±0.1 | 1.25±0.1 | 0.5/+0.05-0.1 | 0.25±0.1 | 0.18±0.1 | 0.5±0.1 |

Part Numbering System

General Capacitors

High Capacitance Capacitors

Super Small Size Capacitors

Medium-High Voltage Capacitors

Array Type Capacitors

Low ESL Capacitors

Reliability Test Condition

Premium Capacitors for Automotive Applications

Packaging Specification

Application Manual for Surface Mounting

Low ESL Capacitors Table (LICC)

| TC | Size(mm) | Tmax(mm) | Vr(V) | Capacitance (uF) | | | | | | | | | |
|------|------------|----------|-------|------------------|-------|-------|-----|------|------|---|-----|-----|----|
| | | | | 0.01 | 0.022 | 0.047 | 0.1 | 0.22 | 0.47 | 1 | 2.2 | 4.7 | 10 |
| 0402 | 0204(0510) | 0.35mm | 4 | X6S | | | | | | | | | |
| | | | 6.3 | X7S | | | | | | | | | |
| | 0306(0816) | 0.55mm | 4 | X7S | | | | | | | | | |

| TC | Size(mm) | Tmax(mm) | Vr(V) | Capacitance (uF) | | | | | | | | | |
|-------------|------------|----------|-------|------------------|-------|-------|-----|------|------|---|-----|-----|----|
| | | | | 0.01 | 0.022 | 0.047 | 0.1 | 0.22 | 0.47 | 1 | 2.2 | 4.7 | 10 |
| X7R /X5R | 0.03(0816) | 0.55mm | 6.3 | X7R | | | | | X5R | | | | |
| | | | 0 | X7R | | | | | | | | | |
| | | | 16 | X7R | | | | | | | | | |
| | | | 25 | X7R | | | | | | | | | |
| | | | 50 | X7R | | | | | | | | | |

Low ESL Capacitors Table (SLIC)

| TC | Vr(V) | Tmax(mm) | Vr(V) | Capacitance (uF) | | | | | | | |
|---------------------|------------|----------|-------|------------------|------|------|---|-----|-----|----|----|
| | | | | 0.1 | 0.47 | 0.68 | 1 | 2.2 | 4.7 | 10 | 22 |
| X7R /X5R /X7T | 0603(1608) | 0.55 | 2.5 | | | | | | | | |
| | | | 4 | X7S | | | | | | | |
| | 0805(0212) | 0.55 | 4 | X7S | | | | | | | |
| | | | 6.3 | X7R | | | | | | | |
| | | 16 | X7R | | | | | | | | |

Product Lineup (Low ESL Capacitors-X7R, X6S, X7S)

| | Part Number | Size L×W (mm) | Capacitance | Rated Voltage (Vdc) | Capacitance Tolerance | Thickness Max. (mm) |
|---|------------------|---------------|-------------|---------------------|-----------------------|---------------------|
| 1 | CL21B104MO5NJV □ | 2.00×1.25 | 100nF | 16 | ±20% | 0.55 |
| 2 | CL21B684MO5NJV □ | | 680nF | 16 | ±20% | 0.55 |
| 3 | CL21B684MQ5NJV □ | | 680nF | 6.3 | ±20% | 0.55 |
| 1 | CLL5X224MR3NLN □ | 0.50×1.00 | 220nF | 4 | ±20% | 0.35 |
| 2 | CLL5X474MR3NLN □ | | 470nF | 4 | ±20% | 0.35 |
| 1 | CLL5Y104MQ3NLN □ | 0.50×1.00 | 100nF | 6.3 | ±20% | 0.35 |
| 2 | CL01Y105MR5NLN □ | | 1μF | 4 | ±20% | 0.55 |
| 3 | CL01Y225MR5NLN □ | 0.80×1.60 | 2.2μF | 4 | ±20% | 0.55 |
| 4 | CL10Y474MR5NJV □ | | 470nF | 4 | ±20% | 0.55 |
| 5 | CL10Y105MR5NJV □ | 1.60×0.80 | 1μF | 4 | ±20% | 0.55 |
| 6 | CL10Y225MR5NJV □ | | 2.2μF | 4 | ±20% | 0.55 |
| 7 | CL21Y105MR5NJV □ | 2.00×1.25 | 1μF | 4 | ±20% | 0.55 |
| 8 | CL21Y225MR5NJV □ | | 2.2μF | 4 | ±20% | 0.55 |

※ □ mark means packaging code. If you want to learn the code or quantity in detail, please see p80.

Part Numbering System

General Capacitors

High Capacitance Capacitors

Super Small Size Capacitors

Medium-High Voltage Capacitors

Array Type Capacitors

Low ESL Capacitors

Reliability Test Condition

Premium Capacitors for Automotive Applications

Packaging Specification

Application Manual for Surface Mounting

| No | Item | Performance | Test Condition | | | | | | | | | | | | | | | | | | | | | | | | | | | |
|--|--|---|--|-------------|-----------------------|------------|-----------------------------------|------------|-----------------------------------|----------------|----------------------|---------------|----------------|-------------------|-----------------------------------|-----|-----------------------|-------|----------------------|---------------|------|-----------------|----------------------------------|-----|-----------------------------------|-----|-----------------------|--------|----------|---|
| 1 | Appearance | No abnormal exterior appearance | Visual Inspection through Microscope(× 10) | | | | | | | | | | | | | | | | | | | | | | | | | | | |
| 2 | Insulation Resistance | 10,000MΩ min. or 500MΩ · μF min.(or *100MΩ · μF) product whichever is smaller (Rated voltage ≤ 16V: 10,000MΩ min. or 100MΩ · μF min. product whichever is smaller) | Apply the rated voltage for 60~120 sec. Rated voltage > 500V: Insulation Resistance shall be measured with 500 ± 50Vdc | | | | | | | | | | | | | | | | | | | | | | | | | | | |
| 3 | Withstanding Voltage | No dielectric breakdown or mechanical breakdown | Apply the specified voltage* for 1~5 sec. Charge/Discharge current limit: 50mA max. *CLASS I (Rated Voltage < 100V): 300% of the rated Voltage CLASS II (Rated Voltage < 100V): 250% of the rated Voltage In the case of Vr ≥ 100V products, following condition should be applied. 100V ≤ Rated Voltage < 500V: 200% of the rated Voltage 500V ≤ Rated Voltage < 1000V: 150% of the rated Voltage Rated Voltage ≥ 1000V: 120% of the rated Voltage | | | | | | | | | | | | | | | | | | | | | | | | | | | |
| 4 | Capacitance | CLASS I Within the specified tolerance | <table border="1"> <thead> <tr> <th>Capacitance</th> <th>Frequency</th> <th>Voltage</th> </tr> </thead> <tbody> <tr> <td>≤ 1,000pF</td> <td>1MHz ± 10%</td> <td rowspan="2">0.5 ~ 5 Vrms</td> </tr> <tr> <td>> 1,000pF</td> <td>1KHz ± 10%</td> </tr> </tbody> </table> | Capacitance | Frequency | Voltage | ≤ 1,000pF | 1MHz ± 10% | 0.5 ~ 5 Vrms | > 1,000pF | 1KHz ± 10% | | | | | | | | | | | | | | | | | | | |
| | | Capacitance | Frequency | Voltage | | | | | | | | | | | | | | | | | | | | | | | | | | |
| ≤ 1,000pF | 1MHz ± 10% | 0.5 ~ 5 Vrms | | | | | | | | | | | | | | | | | | | | | | | | | | | | |
| > 1,000pF | 1KHz ± 10% | | | | | | | | | | | | | | | | | | | | | | | | | | | | | |
| CLASS II Within the specified tolerance | <table border="1"> <thead> <tr> <th>Capacitance</th> <th>Frequency</th> <th>Voltage</th> </tr> </thead> <tbody> <tr> <td>≤ 10μF</td> <td>1KHz ± 10%</td> <td>1.0 ± 0.2 Vrms</td> </tr> <tr> <td>> 10μF</td> <td>120Hz ± 20%</td> <td>0.5 ± 0.1 Vrms</td> </tr> <tr> <td>*</td> <td>1KHz ± 10%</td> <td>0.5 ± 0.1 Vrms</td> </tr> </tbody> </table> | Capacitance | Frequency | Voltage | ≤ 10μF | 1KHz ± 10% | 1.0 ± 0.2 Vrms | > 10μF | 120Hz ± 20% | 0.5 ± 0.1 Vrms | * | 1KHz ± 10% | 0.5 ± 0.1 Vrms | | | | | | | | | | | | | | | | | |
| Capacitance | Frequency | Voltage | | | | | | | | | | | | | | | | | | | | | | | | | | | | |
| ≤ 10μF | 1KHz ± 10% | 1.0 ± 0.2 Vrms | | | | | | | | | | | | | | | | | | | | | | | | | | | | |
| > 10μF | 120Hz ± 20% | 0.5 ± 0.1 Vrms | | | | | | | | | | | | | | | | | | | | | | | | | | | | |
| * | 1KHz ± 10% | 0.5 ± 0.1 Vrms | | | | | | | | | | | | | | | | | | | | | | | | | | | | |
| 5 | Tanδ | CLASS I Capacitance ≥ 30pF : Q ≥ 1,000 < 30pF : Q ≥ 400 + 20 × C (C : Capacitance) | <table border="1"> <thead> <tr> <th>Capacitance</th> <th>Frequency</th> <th>Voltage</th> </tr> </thead> <tbody> <tr> <td>≤ 1,000pF</td> <td>1MHz ± 10%</td> <td rowspan="2">0.5 ~ 5 Vrms</td> </tr> <tr> <td>> 1,000pF</td> <td>1KHz ± 10%</td> </tr> </tbody> </table> | Capacitance | Frequency | Voltage | ≤ 1,000pF | 1MHz ± 10% | 0.5 ~ 5 Vrms | > 1,000pF | 1KHz ± 10% | | | | | | | | | | | | | | | | | | | |
| | | Capacitance | Frequency | Voltage | | | | | | | | | | | | | | | | | | | | | | | | | | |
| ≤ 1,000pF | 1MHz ± 10% | 0.5 ~ 5 Vrms | | | | | | | | | | | | | | | | | | | | | | | | | | | | |
| > 1,000pF | 1KHz ± 10% | | | | | | | | | | | | | | | | | | | | | | | | | | | | | |
| CLASS II | <p>1. Characteristic: A(X5R)</p> <table border="1"> <thead> <tr> <th>Rated Voltage</th> <th>Spec</th> </tr> </thead> <tbody> <tr> <td>50V / 35V</td> <td>0.025 max / 0.05 max*</td> </tr> <tr> <td>25V</td> <td>0.025 max / 0.05 max* / 0.10 max*</td> </tr> <tr> <td>16V</td> <td>0.035 max / 0.05 max* / 0.10 max*</td> </tr> <tr> <td>≤ 10V</td> <td>0.05 max / 0.10 max*</td> </tr> </tbody> </table> <p>2. Characteristic: B(X7R), X(X6S), Y(X7S)</p> <table border="1"> <thead> <tr> <th>Rated Voltage</th> <th>Spec</th> </tr> </thead> <tbody> <tr> <td>50V ≥ / 35V / 25V</td> <td>0.025 max / 0.05 max* / 0.10 max*</td> </tr> <tr> <td>16V</td> <td>0.035 max / 0.10 max*</td> </tr> <tr> <td>≤ 10V</td> <td>0.05 max / 0.10 max*</td> </tr> </tbody> </table> <p>3. Characteristic: F(Y5V)</p> <table border="1"> <thead> <tr> <th>Rated Voltage</th> <th>Spec</th> </tr> </thead> <tbody> <tr> <td>50V / 35V / 25V</td> <td>0.05 max / 0.07 max* / 0.09 max*</td> </tr> <tr> <td>16V</td> <td>0.07 max / 0.09 max* / 0.125 max*</td> </tr> <tr> <td>10V</td> <td>0.125 max / 0.16 max*</td> </tr> <tr> <td>≤ 6.3V</td> <td>0.16 max</td> </tr> </tbody> </table> | Rated Voltage | Spec | 50V / 35V | 0.025 max / 0.05 max* | 25V | 0.025 max / 0.05 max* / 0.10 max* | 16V | 0.035 max / 0.05 max* / 0.10 max* | ≤ 10V | 0.05 max / 0.10 max* | Rated Voltage | Spec | 50V ≥ / 35V / 25V | 0.025 max / 0.05 max* / 0.10 max* | 16V | 0.035 max / 0.10 max* | ≤ 10V | 0.05 max / 0.10 max* | Rated Voltage | Spec | 50V / 35V / 25V | 0.05 max / 0.07 max* / 0.09 max* | 16V | 0.07 max / 0.09 max* / 0.125 max* | 10V | 0.125 max / 0.16 max* | ≤ 6.3V | 0.16 max | You can check the specification at the web site or contact sales people for each product with mark* |
| Rated Voltage | Spec | | | | | | | | | | | | | | | | | | | | | | | | | | | | | |
| 50V / 35V | 0.025 max / 0.05 max* | | | | | | | | | | | | | | | | | | | | | | | | | | | | | |
| 25V | 0.025 max / 0.05 max* / 0.10 max* | | | | | | | | | | | | | | | | | | | | | | | | | | | | | |
| 16V | 0.035 max / 0.05 max* / 0.10 max* | | | | | | | | | | | | | | | | | | | | | | | | | | | | | |
| ≤ 10V | 0.05 max / 0.10 max* | | | | | | | | | | | | | | | | | | | | | | | | | | | | | |
| Rated Voltage | Spec | | | | | | | | | | | | | | | | | | | | | | | | | | | | | |
| 50V ≥ / 35V / 25V | 0.025 max / 0.05 max* / 0.10 max* | | | | | | | | | | | | | | | | | | | | | | | | | | | | | |
| 16V | 0.035 max / 0.10 max* | | | | | | | | | | | | | | | | | | | | | | | | | | | | | |
| ≤ 10V | 0.05 max / 0.10 max* | | | | | | | | | | | | | | | | | | | | | | | | | | | | | |
| Rated Voltage | Spec | | | | | | | | | | | | | | | | | | | | | | | | | | | | | |
| 50V / 35V / 25V | 0.05 max / 0.07 max* / 0.09 max* | | | | | | | | | | | | | | | | | | | | | | | | | | | | | |
| 16V | 0.07 max / 0.09 max* / 0.125 max* | | | | | | | | | | | | | | | | | | | | | | | | | | | | | |
| 10V | 0.125 max / 0.16 max* | | | | | | | | | | | | | | | | | | | | | | | | | | | | | |
| ≤ 6.3V | 0.16 max | | | | | | | | | | | | | | | | | | | | | | | | | | | | | |

| No | Item | Performance | Test Condition | | | | | | | | | | | | |
|-----------------------|--|--|--|-----------------|----------------------------|----------------|---|----------|---|----------|--------------|-------------|----------------------------|---|--------|
| 6 | Temperature Characteristics of Capacitance | CLASS I | <table border="1"> <thead> <tr> <th>Characteristic</th> <th>Temp. Coefficient (PPM/°C)</th> </tr> </thead> <tbody> <tr> <td>C</td> <td>0 ± 30</td> </tr> </tbody> </table> | Characteristic | Temp. Coefficient (PPM/°C) | C | 0 ± 30 | | | | | | | | |
| | | Characteristic | Temp. Coefficient (PPM/°C) | | | | | | | | | | | | |
| C | 0 ± 30 | | | | | | | | | | | | | | |
| CLASS II | <table border="1"> <thead> <tr> <th>Characteristic</th> <th>Capacitance Change (%) with No bias</th> </tr> </thead> <tbody> <tr> <td>A(X5R) / B(X7R)</td> <td>± 15%</td> </tr> <tr> <td>X(X6S), Y(X7S)</td> <td>± 22%</td> </tr> <tr> <td>F(Y5V)</td> <td>+22% ~ -82%</td> </tr> </tbody> </table> | Characteristic | Capacitance Change (%) with No bias | A(X5R) / B(X7R) | ± 15% | X(X6S), Y(X7S) | ± 22% | F(Y5V) | +22% ~ -82% | | | | | | |
| Characteristic | Capacitance Change (%) with No bias | | | | | | | | | | | | | | |
| A(X5R) / B(X7R) | ± 15% | | | | | | | | | | | | | | |
| X(X6S), Y(X7S) | ± 22% | | | | | | | | | | | | | | |
| F(Y5V) | +22% ~ -82% | | | | | | | | | | | | | | |
| | | | <p>Capacitance shall be measured by the steps shown in the following table.</p> <table border="1"> <thead> <tr> <th>Step</th> <th>Temperature(°C)</th> </tr> </thead> <tbody> <tr> <td>1</td> <td>25 ± 2</td> </tr> <tr> <td>2</td> <td>Min. Operating Temp. ± 2</td> </tr> <tr> <td>3</td> <td>25 ± 2</td> </tr> <tr> <td>4</td> <td>Max. Operating Temp. ± 2</td> </tr> <tr> <td>5</td> <td>25 ± 2</td> </tr> </tbody> </table> <p>(1) CLASS I Temperature Coefficient shall be calculated from the formula as below Temp. Coefficient = $\frac{C2 - C1}{C1 \times \Delta T} \times 10^6$ [ppm/°C] C1: Capacitance at step 3 C2: Capacitance at 85°C ΔT: 60°C (= 85°C - 25°C)</p> <p>(2) CLASS II Capacitance Change shall be calculated from the formula as below ΔC = $\frac{C2 - C1}{C1} \times 100$ (%) C1: Capacitance at step 3 C2: Capacitance at step 2 or 4</p> | Step | Temperature(°C) | 1 | 25 ± 2 | 2 | Min. Operating Temp. ± 2 | 3 | 25 ± 2 | 4 | Max. Operating Temp. ± 2 | 5 | 25 ± 2 |
| Step | Temperature(°C) | | | | | | | | | | | | | | |
| 1 | 25 ± 2 | | | | | | | | | | | | | | |
| 2 | Min. Operating Temp. ± 2 | | | | | | | | | | | | | | |
| 3 | 25 ± 2 | | | | | | | | | | | | | | |
| 4 | Max. Operating Temp. ± 2 | | | | | | | | | | | | | | |
| 5 | 25 ± 2 | | | | | | | | | | | | | | |
| 7 | Adhesive Strength of Termination | No indication of peeling shall occur on the terminal electrode | <p>Apply 500g.f* pressure for 10 ± 1 sec. *200g.f for 0201 *100g.f for 01005</p> | | | | | | | | | | | | |
| 8 | Bending Strength | Appearance | No indication of peeling shall occur | | | | | | | | | | | | |
| | | Capacitance | <table border="1"> <thead> <tr> <th>Characteristic</th> <th>Capacitance Change</th> </tr> </thead> <tbody> <tr> <td>CLASS I</td> <td>± 5% or ± 0.5 pF whichever is larger</td> </tr> <tr> <td>CLASS II</td> <td>A(X5R), B(X7R), X(X6S), Y(X7S) ± 12.5% F(Y5V) ± 30%</td> </tr> </tbody> </table> | Characteristic | Capacitance Change | CLASS I | ± 5% or ± 0.5 pF whichever is larger | CLASS II | A(X5R), B(X7R), X(X6S), Y(X7S) ± 12.5% F(Y5V) ± 30% | | | | | | |
| Characteristic | Capacitance Change | | | | | | | | | | | | | | |
| CLASS I | ± 5% or ± 0.5 pF whichever is larger | | | | | | | | | | | | | | |
| CLASS II | A(X5R), B(X7R), X(X6S), Y(X7S) ± 12.5% F(Y5V) ± 30% | | | | | | | | | | | | | | |
| 9 | Solderability | More than 75% of the terminal surface is to be soldered newly, so metal part does not come out or dissolve | <table border="1"> <tbody> <tr> <td>Solder</td> <td>Sn-3Ag-0.5Cu</td> </tr> <tr> <td>Solder Temp.</td> <td>245 ± 5°C</td> </tr> <tr> <td>Flux</td> <td>RMA Type</td> </tr> <tr> <td>Dip time</td> <td>3 ± 0.3 sec.</td> </tr> <tr> <td>Pre-heating</td> <td>at 80~120°C for 10~30 sec.</td> </tr> </tbody> </table> | Solder | Sn-3Ag-0.5Cu | Solder Temp. | 245 ± 5°C | Flux | RMA Type | Dip time | 3 ± 0.3 sec. | Pre-heating | at 80~120°C for 10~30 sec. | | |
| Solder | Sn-3Ag-0.5Cu | | | | | | | | | | | | | | |
| Solder Temp. | 245 ± 5°C | | | | | | | | | | | | | | |
| Flux | RMA Type | | | | | | | | | | | | | | |
| Dip time | 3 ± 0.3 sec. | | | | | | | | | | | | | | |
| Pre-heating | at 80~120°C for 10~30 sec. | | | | | | | | | | | | | | |
| 10 | Resistance to Soldering Heat | Appearance | No mechanical damage shall occur | | | | | | | | | | | | |
| | | Capacitance | <table border="1"> <thead> <tr> <th>Characteristic</th> <th>Capacitance Change</th> </tr> </thead> <tbody> <tr> <td>CLASS I</td> <td>± 2.5% or ± 0.25 pF whichever is larger</td> </tr> <tr> <td>CLASS II</td> <td>A(X5R), B(X7R) X(X6S), Y(X7S) ± 7.5% F(Y5V) ± 20%</td> </tr> </tbody> </table> | Characteristic | Capacitance Change | CLASS I | ± 2.5% or ± 0.25 pF whichever is larger | CLASS II | A(X5R), B(X7R) X(X6S), Y(X7S) ± 7.5% F(Y5V) ± 20% | | | | | | |
| | | Characteristic | Capacitance Change | | | | | | | | | | | | |
| | | CLASS I | ± 2.5% or ± 0.25 pF whichever is larger | | | | | | | | | | | | |
| | | CLASS II | A(X5R), B(X7R) X(X6S), Y(X7S) ± 7.5% F(Y5V) ± 20% | | | | | | | | | | | | |
| | | Q (CLASS I) | Within the specified initial value | | | | | | | | | | | | |
| Tanδ (CLASS II) | Within the specified initial value | | | | | | | | | | | | | | |
| Insulation resistance | Within the specified initial value | | | | | | | | | | | | | | |
| Withstanding voltage | Within the specified initial value | | | | | | | | | | | | | | |
| | | | <p>Solder temperature: 270 ± 5°C DIP TIME: 10 ± 1 sec. Each termination shall be fully immersed and preheated as below:</p> <table border="1"> <thead> <tr> <th>Step</th> <th>Temperature(°C)</th> <th>Time (sec.)</th> </tr> </thead> <tbody> <tr> <td>1</td> <td>80~100</td> <td>60</td> </tr> <tr> <td>2</td> <td>150~180</td> <td>60</td> </tr> </tbody> </table> <p>Leave the capacitor in ambient condition for specified time* before measurement *24 ± 2 hours(CLASS I) 24 ± 2 hours(CLASS II)</p> | Step | Temperature(°C) | Time (sec.) | 1 | 80~100 | 60 | 2 | 150~180 | 60 | | | |
| Step | Temperature(°C) | Time (sec.) | | | | | | | | | | | | | |
| 1 | 80~100 | 60 | | | | | | | | | | | | | |
| 2 | 150~180 | 60 | | | | | | | | | | | | | |

Part Numbering System

General Capacitors

High Capacitance Capacitors

Super Small Size Capacitors

Medium-High Voltage Capacitors

Array Type Capacitors

Low ESL Capacitors

Reliability Test Condition

Premium Capacitors for Automotive Applications

Packaging Specification

Application Manual for Surface Mounting

| No | Item | Performance | Test Condition | | |
|-----------------------|---|-----------------|--|--|--------|
| 11 | Vibration Test | Appearance | No mechanical damage shall occur | | |
| | | Capacitance | Characteristic | Capacitance Change | |
| | | | CLASS I | ±2.5% or ± 0.25 pF whichever is larger | |
| | | | CLASS II | A(X5R), B(X7R) | ±5% |
| | | | | X(X6S), Y(X7S) | ±10% |
| | | F(Y5V) | | ±20% | |
| | | Q (CLASS I) | Within the specified initial value | | |
| Tanδ (CLASS II) | Within the specified initial value | | | | |
| Insulation resistance | Within the specified initial value | | | | |
| 12 | Moisture Resistance | Appearance | No mechanical damage shall occur | | |
| | | Capacitance | Characteristic | Capacitance Change | |
| | | | CLASS I | ±7.5% or ± 0.75pF whichever is larger | |
| | | | CLASS II | A(X5R), B(X7R), X(X6S), Y(X7S) | ±12.5% |
| | | | | F(Y5V) | ±30% |
| | | Q (CLASS I) | Capacitance ≥ 30pF : Q ≥ 200 < 30pF : Q ≥ 100+10/3 × C (C: Capacitance) | | |
| | | Tanδ (CLASS II) | 1.Capacitance: A(X5R) 0.05 max / 0.075 max* (35V / 50V) 0.05 max / 0.075 max* / 0.125 max*(16V / 25V) 0.075 max / 0.125 max* (≤ 10V) 2.Capacitance: B(X7R), X(X6S) 0.05 max / 0.125 max* (16V / 25V / 35V / 50V ≥) 0.075 max / 0.125 max* (≤ 10V) 3.Capacitance: F(Y5V) 0.09 max (50V) 0.09 max / 0.125 max* (25V / 35V) 0.09 max / 0.125 max* / 0.16 max* (16V) 0.16 max / 0.195 max* (10V) 0.195 max (4V / 6.3V) | | |
| Insulation resistance | 500MΩ min. or 25MΩ · μF min. product whichever is smaller / 12.5MΩ · μF or over* | | | | |
| 13 | High Temperature Resistance | Appearance | No mechanical damage shall occur | | |
| | | Capacitance | Characteristic | Capacitance Change | |
| | | | CLASS I | ±3% or ± 0.3 pF whichever is larger | |
| | | | CLASS II | A(X5R), B(X7R), X(X6S), Y(X7S) | ±12.5% |
| | | | | F(Y5V) | ±30% |
| | | Q (CLASS I) | Capacitance ≥ 30pF : Q ≥ 350 10 ≤ Capacitance < 30pF : Q ≥ 275+2.5 × C Capacitance < 10pF : Q ≥ 200+10 × C (C: Capacitance) | | |
| | | Tanδ (CLASS II) | 1.Capacitance: A(X5R) 0.05 max / 0.075 max* (35V / 50V) 0.05 max / 0.075 max* / 0.125 max*(16V / 25V) 0.075 max / 0.125 max* (≤ 10V) 2.Capacitance: B(X7R), X(X6S) 0.05 max / 0.125 max* (16V / 25V / 35V / 50V ≥) 0.075 max / 0.125 max* (≤ 10V) 3.Capacitance: F(Y5V) 0.09 max (50V) 0.09 max / 0.125 max* (25V / 35V) 0.09 max / 0.125 max* / 0.16 max* (16V) 0.16 max / 0.195 max* (10V) 0.195 max (4V / 6.3V) | | |
| Insulation resistance | 1,000MΩ min. or 50MΩ · μF min. product whichever is smaller / 25MΩ · μF or over* | | | | |

| No | Item | Performance | Test Condition | | | | |
|---|---|---------------|------------------------------------|---------------------------------------|-----------|--------|---|
| 14 | Temperature Cycle | Appearance | No mechanical damage shall occur | | | | |
| | | Capacitance | Characteristic | Capacitance Change | | | |
| | | | CLASS I | ±2.5% or ± 0.25pF whichever is larger | | | |
| | | | CLASS II | A(X5R), B(X7R) | ±7.5% | | |
| | | | | X(X6S), Y(X7S) | ±15% | | |
| | | F(Y5V) | ±20% | | | | |
| | | Q (CLASS I) | Within the specified initial value | | | | |
| Tanδ (CLASS II) | Within the specified initial value | | | | | | |
| Insulation resistance | Within the specified initial value | | | | | | |
| Capacitor shall be subjected to 5 cycles. Condition for 1 cycle: | | | | | | | |
| | | Step | Temperature(°C) | Time(min.) | | | |
| | | 1 | min. operating temperature +0/-3 | 30 | | | |
| | | 2 | 25 | 2~3 | | | |
| | | 3 | max. operating temperature +0/-3 | 30 | | | |
| | | 4 | 25 | 2~3 | | | |
| Leave the capacitor in ambient condition for specified time* before measurement *24 ± 2 hours(CLASS I) 24 ± 2 hours(CLASS II) | | | | | | | |
| Recommended Soldering Method | | | | | | | |
| No | Item | Performance | Test Condition | | | | |
| 15 | Recommended Soldering Method By Size & Capacitance | Size inch(mm) | Temperature Characteristic | Capacitance | | | |
| | | 01005(0402) | - | - | Condition | | |
| | | 0201 (0603) | | | Flow | Reflow | |
| | | 0402 (1005) | | | - | ○ | |
| | | 0603(1608) | Class I | - | ○ | ○ | |
| | | | Class II | C < 1μF | ○ | ○ | |
| | | 0805 (2012) | Class I | - | ○ | ○ | |
| | | | | C < 4.7μF | ○ | ○ | |
| | | | Class II | C ≥ 4.7μF | - | ○ | |
| | | 1206 (3216) | Array | - | - | ○ | |
| | | | Class I | - | ○ | ○ | |
| | | | Class II | C < 10μF | ○ | ○ | |
| | | 1210 (3225) | - | - | - | - | ○ |
| | | | | | | | ○ |
| | | 1808 (4520) | - | - | - | - | ○ |
| 1812 (4532) | ○ | | | | | | |
| 2220 (5750) | ○ | | | | | | |

Note1. Initial Measurement For Class II

Perform the heat treatment at 150°C+0/-10°C for 1 hour. Then Leave the capacitor in ambient condition for 24 ± 2 hours before measurement. Then perform the measurement.

Note2. Latter Measurement

1. CLASS I
Leave the capacitor in ambient condition for 24 ± 2 hours before measurement. Then perform the measurement.

2. CLASS II
Perform the heat treatment at 150°C+0/-10°C for 1 hour. Then Leave the capacitor in ambient condition for 24 ± 2 hours before measurement. Then perform the measurement.

Note3. All Size in Reliability Test Condition Section is "inch"

Note4. Camera Strobe Circuit Capacitors Should be Following a Special Reliability Test Condition.
Please check with our sales representatives or product engineers.

Part Numbering System

General Capacitors

High Capacitance Capacitors

Super Small Size Capacitors

Medium-High Voltage Capacitors

Array Type Capacitors

Low ESL Capacitors

Reliability Test Condition

Premium Capacitors for Automotive Applications

Packaging Specification

Application Manual for Surface Mounting

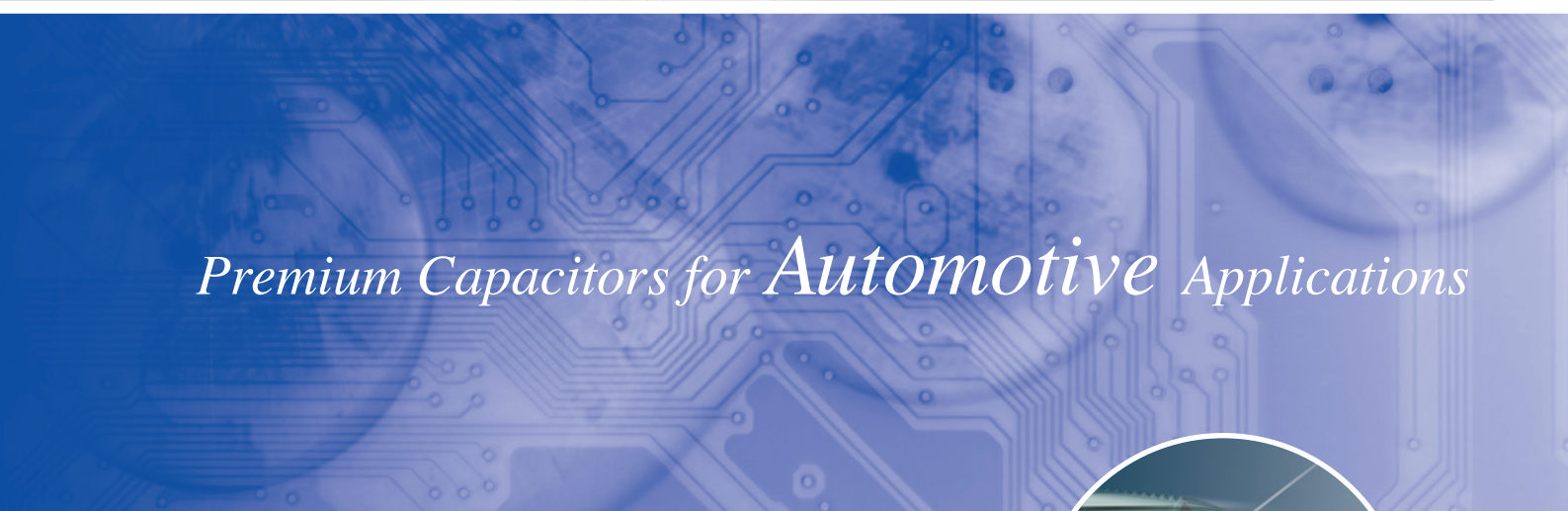
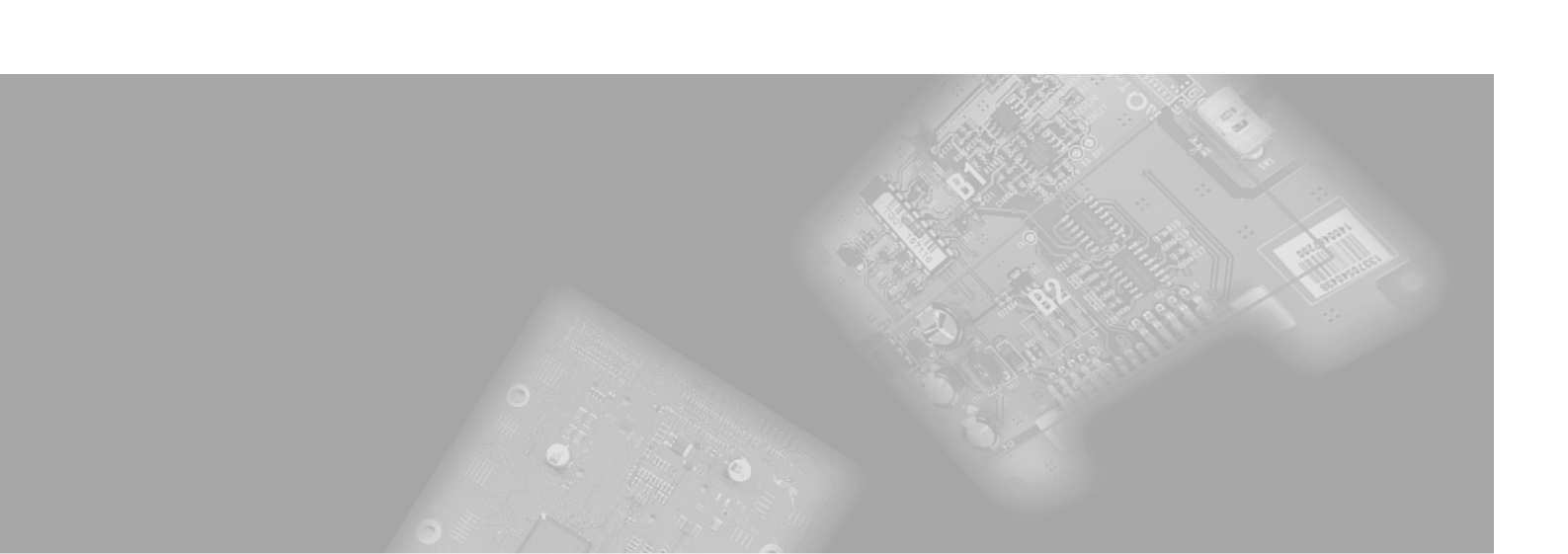
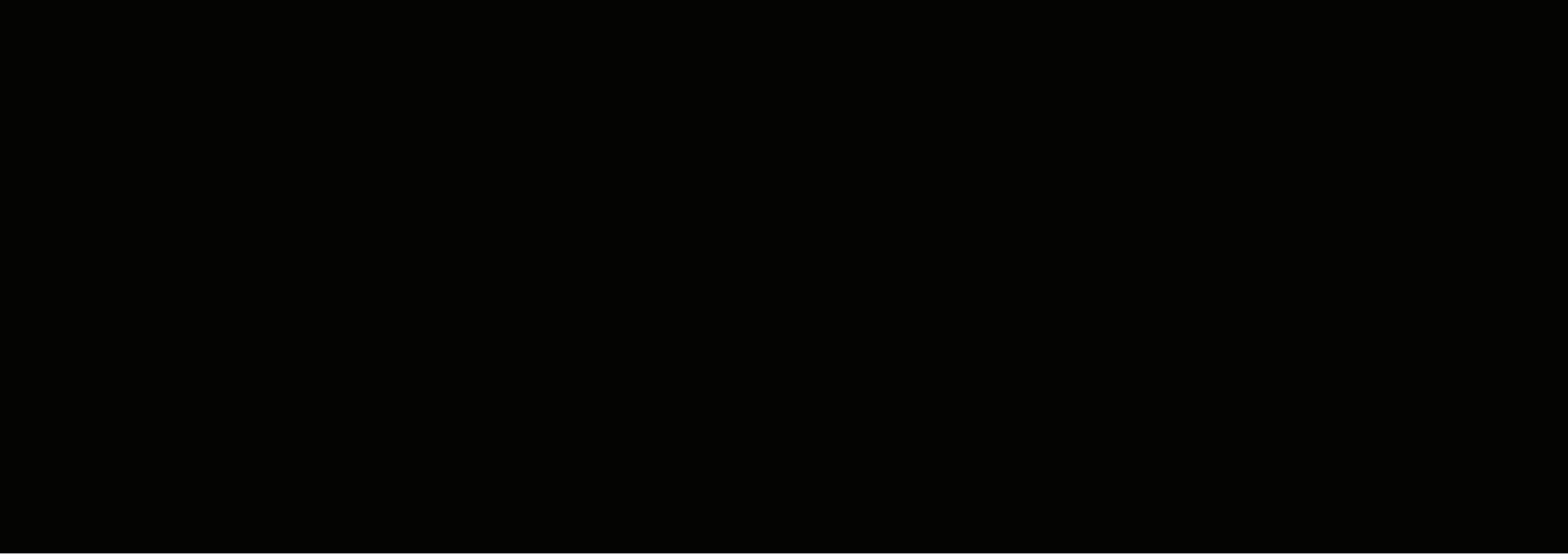

S A M S U N G E L E C T R O - M E C H A N I C S

Premium Capacitors for Automotive Applications

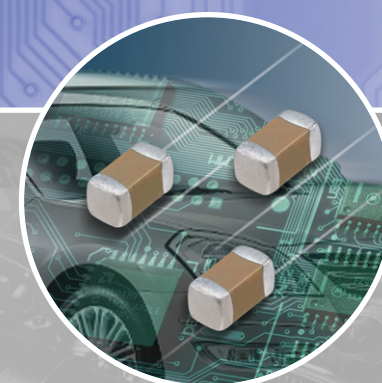

Part Numbering System (Automotive Capacitors)

| | | | | | | | | | | | |
|--|-----------|-----------|----------|------------|----------|----------|----------|----------|----------|-----------|-----------|
| | CL | 10 | B | 104 | K | B | 8 | 5 | P | N | C |
| | 1 | 2 | 3 | 4 | 5 | 6 | 7 | 8 | 9 | 10 | 11 |

- 1. SERIES CODE** _____
CL=Multi layer Ceramic Capacitors
- 2. SIZE CODE** — inch (mm) _____
05=1005(0402) 10=1608(0603) 21=2012(0805)
31=3216(1206) 32=3225(1210)
- 3. DIELECTRIC CODE** _____
C=COG (Class I) B=X7R (Class II)
- 4. CAPACITANCE CODE** _____
Capacitance expressed in pF. 2 significant digits plus number of zeros.
example) 106=10 × 10⁶=10000000pF
For Values < 10pF, Letter R denotes decimal point
example) 1R5=1.5pF
- 5. TOLERANCE CODE** _____
C=±0.25pF D=±0.5pF F=±1pF, ±1%* G=±2%
J=±5% K=±10% M=±20%
*For Values ≤10pF, F=±1pF, Values>10pF, F=±1%
∴This code has only typical specifications. Please refer to individual specifications.
- 6. RATED VOLTAGE CODE** _____
P=10V O=16V
A=25V B=50V C=100V
- 7. THICKNESS CODE** _____
5 = 0.50mm 6= 0.60mm 8 = 0.80mm C = 0.85mm
P = 1.15mm F = 1.25mm H = 1.60mm J = 2.50mm
∴This code has only typical specifications. Please refer to individual specifications.
- 8. DESIGN CODE** _____
1=Ni/Cu/Ni Barrier/Sn 100%/Standard
4=Ni/Cu+Ag-Epoxy/Ni Barrier/Sn 100%/Standard
5=Ni/Cu+Ag-Epoxy/Ni Barrier/Sn 100%/Open Mode
∴This code has only typical specifications. Please refer to individual specifications.
- 9. PRODUCT CODE** _____
P=Automotive product meet JEDEC-020-D requirements.
∴If orders are placed without returned specification, please allow us to judge that specification is accepted by your side.
- 10. GRADE CODE** _____
N=Standard
- 11. PACKAGING CODE** _____
B = Bulk O = Cardboard Tape, 10" Reel E = Embossed Type, 7" Reel
P = Bulk Case D = Cardboard Tape, 13" Reel(10,000ea) F = Embossed Type, 13" Reel
C = Cardboard Tape, 7" Reel L = Cardboard Tape, 13" Reel(15,000ea) S = Embossed Type, 10" Reel

This catalog has only typical specifications because there is no space for detailed specifications.
Please approve our product specifications or transact the approval sheet for product specifications before ordering.

*** Class I**

| Symbol | EIA Code | Operation Temperature Range(°C) | Temperature Coefficient Range(ppm/°C) |
|--------|----------|---------------------------------|---------------------------------------|
| C | COG | -55 ~ +125 | 0 ±30 |

**** Class II**

| Symbol | EIA Code | Operation Temperature Range(°C) | Capacitance Change (ΔC %) |
|--------|----------|---------------------------------|---------------------------|
| B | X7R | -55 ~ +125 | 0 ±15 |

**** Capacitance Tolerance**

| Code | Capacitance Tolerance | TC | Capacitance Step | Rated Capacitance |
|------|-----------------------|-----|------------------|-------------------|
| C | ±0.25 pF | COG | Under 5 pF | E-12 series * |
| D | ±0.5 pF | COG | 6.0 to 9.0 pF | E-12 series * |
| J | ±5% | COG | Over 10 pF | E-12 series |
| K | ±10% | X7R | Under 0.01 μF | E-3 series |
| | | | Over 0.01 μF | E-6 series |
| M | ±20% | X7R | Under 0.01 μF | E-3 series |
| | | | Over 0.01 μF | E-6 series |

*E-24 series is also available

| Series | Capacitance Step | | | | | | | | | | | |
|--------|------------------|-----|-----|-----|-----|-----|-----|-----|-----|-----|-----|-----|
| | 1.0 | | | | 2.2 | | | | 4.7 | | | |
| E-3 | 1.0 | | | | 2.2 | | | | 4.7 | | | |
| E-6 | 1.0 | 1.5 | 2.2 | 3.3 | 4.7 | 6.8 | | | | | | |
| E-12 | 1.0 | 1.2 | 1.5 | 1.8 | 2.2 | 2.7 | 3.3 | 3.9 | 4.7 | 5.6 | 6.8 | 8.2 |
| E-24 | 1.0 | 1.1 | 1.2 | 1.3 | 2.2 | 2.4 | 2.7 | 3.0 | 4.7 | 5.1 | 5.6 | 6.2 |
| | 1.5 | 1.6 | 1.8 | 2.0 | 3.3 | 3.6 | 3.9 | 4.3 | 6.8 | 7.5 | 8.2 | 9.1 |

| Size | Code | Thickness(mm) | Spec(mm) * |
|------------|------|---------------|------------|
| 0402(1005) | 5 | 0.50 | ±0.05 |
| 0603(1608) | 8 | 0.80 | ±0.10 |
| 0805(2012) | 6 | 0.60 | ±0.10 |
| | C | 0.85 | ±0.10 |
| | F | 1.25 | ±0.10 |
| 1206(3216) | C | 0.85 | ±0.15 |
| | P | 1.15 | ±0.10 |
| | H | 1.60 | ±0.20 |

*The tolerance will be changed by Customer' standards and our new products. (High Capacitance)
Please check with our sales representatives or product engineers before ordering.

Part Numbering System

General Capacitors

High Capacitance Capacitors

Super Small Size Capacitors

Medium-High Voltage Capacitors

Array Type Capacitors

Low ESL Capacitors

Reliability Test Condition

Premium Capacitors for Automotive Applications

Packaging Specification

Application Manual for Surface Mounting

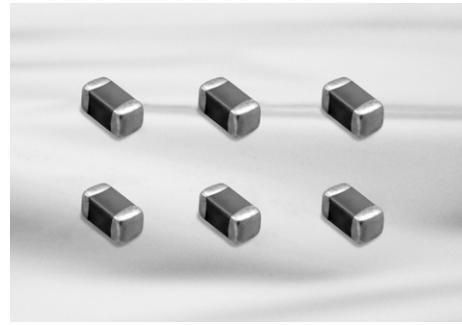

Feature

- Automotive products are manufactured in state of the art facilities recommended for registration to ISO/TS 16949:2002.
- Automotive products meet AEC-Q-200 requirements.
- Automotive products are RoHS compliant.
- Samsung terminations are suitable for all flow and reflow soldering systems. (10/21/31 size type only)
- Automotive products meet JEDEC-020-D requirements.
- COG dielectric components contain BME and copper terminations with a Ni/Sn plated overcoat.
- X7R dielectric components have BME and soft terminations with a Ni/Sn plated overcoat.

Application

- Automotive Electronic Equipment
(Powertrain, Safety, Body & Chassis, Convenience, Infotainment)

Structure and Dimensions

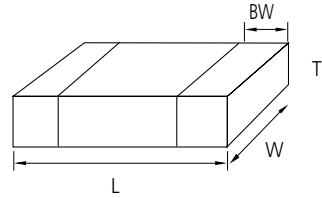

| Code | EIA Code | Dimension(mm) | | | |
|------|----------|---------------|-----------|-------------|---------------|
| | | L | W | T | BW |
| 05 | 0402 | 1.00±0.05 | 0.50±0.05 | 0.50(±0.05) | 0.2+0.15/-0.1 |
| 10 | 0603 | 1.60±0.10 | 0.80±0.10 | 0.80(±0.10) | 0.3±0.2 |
| 21 | 0805 | 2.00±0.10 | 1.25±0.10 | 0.60(±0.10) | 0.5±0.2/-0.3 |
| | | | | 0.85(±0.10) | |
| | | | | 1.25(±0.10) | |
| 31 | 1206 | 3.20±0.20 | 1.60±0.20 | 0.85(±0.15) | 0.5±0.3 |
| | | | | 1.15(±0.10) | |
| | | | | 1.60(±0.20) | |
| | | | | | |

Automotive Capacitors Table (COG, X7R)

| TC | Size(mm) | Vr | Capacitance (pF) | | | Capacitance (nF) | | | | | | |
|-----|------------|-----|--|-----|-----|------------------|-----|-----|----|----|----|-----|
| | | | 100 | 220 | 470 | 1 | 2.2 | 4.7 | 10 | 22 | 47 | 100 |
| COG | 0402(1005) | 50 | [Bar chart showing capacitance values for 0402(1005) at 50Vr] | | | | | | | | | |
| | | 100 | [Bar chart showing capacitance values for 0402(1005) at 100Vr] | | | | | | | | | |
| | 0603(1608) | 50 | [Bar chart showing capacitance values for 0603(1608) at 50Vr] | | | | | | | | | |
| | | 100 | [Bar chart showing capacitance values for 0603(1608) at 100Vr] | | | | | | | | | |
| | 0805(2012) | 50 | [Bar chart showing capacitance values for 0805(2012) at 50Vr] | | | | | | | | | |
| | | 100 | [Bar chart showing capacitance values for 0805(2012) at 100Vr] | | | | | | | | | |

| TC | Size(mm) | Thickness (mm) | Vr | Capacitance (nF) | | | | | | Capacitance (uF) | | | | | |
|-----|------------|----------------|------|---|--|--|-----|-----|-----|------------------|-----|-----|----|--|--|
| | | | | 10 | 22 | 47 | 100 | 220 | 470 | 1 | 2.2 | 4.7 | 10 | | |
| X7R | 0603(1608) | 0.8 | 10 | [Bar chart showing capacitance values for 0603(1608) at 0.8mm thickness, 10Vr] | | | | | | | | | | | |
| | | 0.8 | 16 | [Bar chart showing capacitance values for 0603(1608) at 0.8mm thickness, 16Vr] | | | | | | | | | | | |
| | | 0.8 | 25 | [Bar chart showing capacitance values for 0603(1608) at 0.8mm thickness, 25Vr] | | | | | | | | | | | |
| | | 0.8 | 50 | [Bar chart showing capacitance values for 0603(1608) at 0.8mm thickness, 50Vr] | | | | | | | | | | | |
| | | 0.8 | 100 | [Bar chart showing capacitance values for 0603(1608) at 0.8mm thickness, 100Vr] | | | | | | | | | | | |
| | 0805(2012) | 1.25 | 10 | [Bar chart showing capacitance values for 0805(2012) at 1.25mm thickness, 10Vr] | | | | | | | | | | | |
| | | | 16 | [Bar chart showing capacitance values for 0805(2012) at 1.25mm thickness, 16Vr] | | | | | | | | | | | |
| | | | 25 | [Bar chart showing capacitance values for 0805(2012) at 1.25mm thickness, 25Vr] | | | | | | | | | | | |
| | | 0.6 | 25 | 10 | [Bar chart showing capacitance values for 0805(2012) at 0.6mm thickness, 25Vr] | | | | | | | | | | |
| | | | | 50 | [Bar chart showing capacitance values for 0805(2012) at 0.6mm thickness, 50Vr] | | | | | | | | | | |
| | | | 0.85 | 50 | 10 | [Bar chart showing capacitance values for 0805(2012) at 0.85mm thickness, 50Vr] | | | | | | | | | |
| | | | | | 100 | [Bar chart showing capacitance values for 0805(2012) at 0.85mm thickness, 100Vr] | | | | | | | | | |
| | | 1206(3216) | 1.6 | 10 | [Bar chart showing capacitance values for 1206(3216) at 1.6mm thickness, 10Vr] | | | | | | | | | | |
| | | | | 16 | [Bar chart showing capacitance values for 1206(3216) at 1.6mm thickness, 16Vr] | | | | | | | | | | |
| | | | 0.85 | 25 | 10 | [Bar chart showing capacitance values for 1206(3216) at 0.85mm thickness, 25Vr] | | | | | | | | | |
| | | | | | 50 | [Bar chart showing capacitance values for 1206(3216) at 0.85mm thickness, 50Vr] | | | | | | | | | |
| | | | | | 100 | [Bar chart showing capacitance values for 1206(3216) at 0.85mm thickness, 100Vr] | | | | | | | | | |

Part Numbering System

General Capacitors

High Capacitance Capacitors

Super Small Size Capacitors

Medium-High Voltage Capacitors

Array Type Capacitors

Low ESL Capacitors

Reliability Test Condition

Premium Capacitors for Automotive Applications

Packaging Specification

Application Manual for Surface Mounting

Product Lineup (Automotive Capacitors_COG)

| | Part Number | Size L × W (mm) | Capacitance | Rated Voltage (Vdc) | Capacitance Tolerance | Thickness Max. (mm) |
|----|------------------|-----------------|-------------|---------------------|-----------------------|---------------------|
| 1 | CL05C010CB51PN □ | 1.00×0.50 | 1.0pF | 50 | ±0.25pF | 0.55 |
| 2 | CL05C010CC51PN □ | | 1.0pF | 100 | ±0.25pF | 0.55 |
| 3 | CL05C1R5CB51PN □ | | 1.5pF | 50 | ±0.25pF | 0.55 |
| 4 | CL05C1R5CC51PN □ | | 1.5pF | 100 | ±0.25pF | 0.55 |
| 5 | CL05C2R2CB51PN □ | | 2.2pF | 50 | ±0.25pF | 0.55 |
| 6 | CL05C2R2CC51PN □ | | 2.2pF | 100 | ±0.25pF | 0.55 |
| 7 | CL05C3R3CB51PN □ | | 3.3pF | 50 | ±0.25pF | 0.55 |
| 8 | CL05C3R3CC51PN □ | | 3.3pF | 100 | ±0.25pF | 0.55 |
| 9 | CL05C4R7CB51PN □ | | 4.7pF | 50 | ±0.25pF | 0.55 |
| 10 | CL05C4R7CC51PN □ | | 4.7pF | 100 | ±0.25pF | 0.55 |
| 11 | CL05C6R8DB51PN □ | | 6.8pF | 50 | ±0.5pF | 0.55 |
| 12 | CL05C6R8DC51PN □ | | 6.8pF | 100 | ±0.5pF | 0.55 |
| 13 | CL05C100JB51PN □ | | 10pF | 50 | ±5% | 0.55 |
| 14 | CL05C100JC51PN □ | | 10pF | 100 | ±5% | 0.55 |
| 15 | CL05C120JB51PN □ | | 12pF | 50 | ±5% | 0.55 |
| 16 | CL05C120JC51PN □ | | 12pF | 100 | ±5% | 0.55 |
| 17 | CL05C150JB51PN □ | | 15pF | 50 | ±5% | 0.55 |
| 18 | CL05C150JC51PN □ | | 15pF | 100 | ±5% | 0.55 |
| 19 | CL05C180JB51PN □ | | 18pF | 50 | ±5% | 0.55 |
| 20 | CL05C180JC51PN □ | | 18pF | 100 | ±5% | 0.55 |
| 21 | CL05C220JB51PN □ | | 22pF | 50 | ±5% | 0.55 |
| 22 | CL05C220JC51PN □ | | 22pF | 100 | ±5% | 0.55 |
| 23 | CL05C270JB51PN □ | | 27pF | 50 | ±5% | 0.55 |
| 24 | CL05C270JC51PN □ | | 27pF | 100 | ±5% | 0.55 |
| 25 | CL05C330JB51PN □ | | 33pF | 50 | ±5% | 0.55 |
| 26 | CL05C330JC51PN □ | | 33pF | 100 | ±5% | 0.55 |
| 27 | CL05C390JB51PN □ | | 39pF | 50 | ±5% | 0.55 |
| 28 | CL05C390JC51PN □ | | 39pF | 100 | ±5% | 0.55 |
| 29 | CL05C470JB51PN □ | | 47pF | 50 | ±5% | 0.55 |
| 30 | CL05C470JC51PN □ | | 47pF | 100 | ±5% | 0.55 |
| 31 | CL05C560JB51PN □ | | 56pF | 50 | ±5% | 0.55 |
| 32 | CL05C560JC51PN □ | | 56pF | 100 | ±5% | 0.55 |
| 33 | CL05C680JB51PN □ | | 68pF | 50 | ±5% | 0.55 |
| 34 | CL05C680JC51PN □ | | 68pF | 100 | ±5% | 0.55 |
| 35 | CL05C820JB51PN □ | | 82pF | 50 | ±5% | 0.55 |
| 36 | CL05C820JC51PN □ | | 82pF | 100 | ±5% | 0.55 |
| 37 | CL05C101JB51PN □ | | 100pF | 50 | ±5% | 0.55 |
| 38 | CL05C101JC51PN □ | | 100pF | 100 | ±5% | 0.55 |
| 39 | CL05C121JB51PN □ | | 120pF | 50 | ±5% | 0.55 |
| 40 | CL05C151JB51PN □ | | 150pF | 50 | ±5% | 0.55 |
| 41 | CL05C221JB51PN □ | | 220pF | 50 | ±5% | 0.55 |
| 1 | CL10C010CB81PN □ | 1.60×0.80 | 1.0pF | 50 | ±0.25pF | 0.9 |
| 2 | CL10C010CC81PN □ | | 1.0pF | 100 | ±0.25pF | 0.9 |
| 3 | CL10C1R5CB81PN □ | | 1.5pF | 50 | ±0.25pF | 0.9 |
| 4 | CL10C1R5CC81PN □ | | 1.5pF | 100 | ±0.25pF | 0.9 |

※ □mark means packaging code. If you want to learn the code or quantity in detail, please see p80.

Product Lineup (Automotive Capacitors_COG)

| | Part Number | Size L × W (mm) | Capacitance | Rated Voltage (Vdc) | Capacitance Tolerance | Thickness Max. (mm) |
|----|------------------|-----------------|-------------|---------------------|-----------------------|---------------------|
| 5 | CL10C2R2CB81PN □ | 1.60×0.80 | 2.2pF | 50 | ±0.25pF | 0.9 |
| 6 | CL10C2R2CC81PN □ | | 2.2pF | 100 | ±0.25pF | 0.9 |
| 7 | CL10C3R3CB81PN □ | | 3.3pF | 50 | ±0.25pF | 0.9 |
| 8 | CL10C3R3CC81PN □ | | 3.3pF | 100 | ±0.25pF | 0.9 |
| 9 | CL10C4R7CB81PN □ | | 4.7pF | 50 | ±0.25pF | 0.9 |
| 10 | CL10C4R7CC81PN □ | | 4.7pF | 100 | ±0.25pF | 0.9 |
| 11 | CL10C6R8DB81PN □ | | 6.8pF | 50 | ±0.5pF | 0.9 |
| 12 | CL10C6R8DC81PN □ | | 6.8pF | 100 | ±0.5pF | 0.9 |
| 13 | CL10C100JB81PN □ | | 10pF | 50 | ±5% | 0.9 |
| 14 | CL10C100JC81PN □ | | 10pF | 100 | ±5% | 0.9 |
| 15 | CL10C120JB81PN □ | | 12pF | 50 | ±5% | 0.9 |
| 16 | CL10C120JC81PN □ | | 12pF | 100 | ±5% | 0.9 |
| 17 | CL10C150JB81PN □ | | 15pF | 50 | ±5% | 0.9 |
| 18 | CL10C150JC81PN □ | | 15pF | 100 | ±5% | 0.9 |
| 19 | CL10C180JB81PN □ | | 18pF | 50 | ±5% | 0.9 |
| 20 | CL10C180JC81PN □ | | 18pF | 100 | ±5% | 0.9 |
| 21 | CL10C220JB81PN □ | | 22pF | 50 | ±5% | 0.9 |
| 22 | CL10C220JC81PN □ | | 22pF | 100 | ±5% | 0.9 |
| 23 | CL10C270JB81PN □ | | 27pF | 50 | ±5% | 0.9 |
| 24 | CL10C270JC81PN □ | | 27pF | 100 | ±5% | 0.9 |
| 25 | CL10C330JB81PN □ | | 33pF | 50 | ±5% | 0.9 |
| 26 | CL10C330JC81PN □ | | 33pF | 100 | ±5% | 0.9 |
| 27 | CL10C390JB81PN □ | | 39pF | 50 | ±5% | 0.9 |
| 28 | CL10C390JC81PN □ | | 39pF | 100 | ±5% | 0.9 |
| 29 | CL10C470JB81PN □ | | 47pF | 50 | ±5% | 0.9 |
| 30 | CL10C470JC81PN □ | | 47pF | 100 | ±5% | 0.9 |
| 31 | CL10C560JB81PN □ | | 56pF | 50 | ±5% | 0.9 |
| 32 | CL10C560JC81PN □ | | 56pF | 100 | ±5% | 0.9 |
| 33 | CL10C680JB81PN □ | | 68pF | 50 | ±5% | 0.9 |
| 34 | CL10C680JC81PN □ | | 68pF | 100 | ±5% | 0.9 |
| 35 | CL10C820JB81PN □ | | 82pF | 50 | ±5% | 0.9 |
| 36 | CL10C820JC81PN □ | | 82pF | 100 | ±5% | 0.9 |
| 37 | CL10C101JB81PN □ | | 100pF | 50 | ±5% | 0.9 |
| 38 | CL10C101JC81PN □ | | 100pF | 100 | ±5% | 0.9 |
| 39 | CL10C121JB81PN □ | | 120pF | 50 | ±5% | 0.9 |
| 40 | CL10C151JB81PN □ | | 150pF | 50 | ±5% | 0.9 |
| 41 | CL10C221JB81PN □ | | 220pF | 50 | ±5% | 0.9 |
| 42 | CL10C271JB81PN □ | | 270pF | 50 | ±5% | 0.9 |
| 43 | CL10C331JB81PN □ | | 330pF | 50 | ±5% | 0.9 |
| 44 | CL10C391JB81PN □ | | 390pF | 50 | ±5% | 0.9 |
| 45 | CL10C471JB81PN □ | | 470pF | 50 | ±5% | 0.9 |
| 46 | CL10C561JB81PN □ | | 560pF | 50 | ±5% | 0.9 |
| 47 | CL10C681JB81PN □ | | 680pF | 50 | ±5% | 0.9 |
| 48 | CL10C821JB81PN □ | | 820pF | 50 | ±5% | 0.9 |
| 49 | CL10C102JB81PN □ | | 1000pF | 50 | ±5% | 0.9 |

※ □mark means packaging code. If you want to learn the code or quantity in detail, please see p80.

- Part Numbering System
- General Capacitors
- High Capacitance Capacitors
- Super Small Size Capacitors
- Medium-High Voltage Capacitors
- Array Type Capacitors
- Low ESL Capacitors
- Reliability Test Condition
- Premium Capacitors for Automotive Applications
- Packaging Specification
- Application Manual for Surface Mounting

Product Lineup (Automotive Capacitors_COG)

| | Part Number | Size L × W (mm) | Capacitance | Rated Voltage (Vdc) | Capacitance Tolerance | Thickness Max. (mm) |
|----|------------------|-----------------|-------------|---------------------|-----------------------|---------------------|
| 1 | CL21C100JB61PN □ | 2.00×1.25 | 10pF | 50 | ±5% | 0.7 |
| 2 | CL21C100JC61PN □ | | 10pF | 100 | ±5% | 0.7 |
| 3 | CL21C120JB61PN □ | | 12pF | 50 | ±5% | 0.7 |
| 4 | CL21C120JC61PN □ | | 12pF | 100 | ±5% | 0.7 |
| 5 | CL21C150JB61PN □ | | 15pF | 50 | ±5% | 0.7 |
| 6 | CL21C150JC61PN □ | | 15pF | 100 | ±5% | 0.7 |
| 7 | CL21C180JB61PN □ | | 18pF | 50 | ±5% | 0.7 |
| 8 | CL21C180JC61PN □ | | 18pF | 100 | ±5% | 0.7 |
| 9 | CL21C220JB61PN □ | | 22pF | 50 | ±5% | 0.7 |
| 10 | CL21C220JC61PN □ | | 22pF | 100 | ±5% | 0.7 |
| 11 | CL21C270JC61PN □ | | 27pF | 100 | ±5% | 0.7 |
| 12 | CL21C330JB61PN □ | | 33pF | 50 | ±5% | 0.7 |
| 13 | CL21C330JC61PN □ | | 33pF | 100 | ±5% | 0.7 |
| 14 | CL21C390JB61PN □ | | 39pF | 50 | ±5% | 0.7 |
| 15 | CL21C390JC61PN □ | | 39pF | 100 | ±5% | 0.7 |
| 16 | CL21C470JB61PN □ | | 47pF | 50 | ±5% | 0.7 |
| 17 | CL21C470JC61PN □ | | 47pF | 100 | ±5% | 0.7 |
| 18 | CL21C560JB61PN □ | | 56pF | 50 | ±5% | 0.7 |
| 19 | CL21C560JC61PN □ | | 56pF | 100 | ±5% | 0.7 |
| 20 | CL21C680JB61PN □ | | 68pF | 50 | ±5% | 0.7 |
| 21 | CL21C680JC61PN □ | | 68pF | 100 | ±5% | 0.7 |
| 22 | CL21C820JB61PN □ | | 82pF | 50 | ±5% | 0.7 |
| 23 | CL21C820JC61PN □ | | 82pF | 100 | ±5% | 0.7 |
| 24 | CL21C101JB61PN □ | | 100pF | 50 | ±5% | 0.7 |
| 25 | CL21C101JC61PN □ | | 100pF | 100 | ±5% | 0.7 |
| 26 | CL21C121JB61PN □ | | 120pF | 50 | ±5% | 0.7 |
| 27 | CL21C121JC61PN □ | | 120pF | 100 | ±5% | 0.7 |
| 28 | CL21C151JB61PN □ | | 150pF | 50 | ±5% | 0.7 |
| 29 | CL21C151JC61PN □ | | 150pF | 100 | ±5% | 0.7 |
| 30 | CL21C221JB61PN □ | | 220pF | 50 | ±5% | 0.7 |
| 31 | CL21C221JC61PN □ | | 220pF | 100 | ±5% | 0.7 |
| 32 | CL21C271JB61PN □ | | 270pF | 50 | ±5% | 0.7 |
| 33 | CL21C271JC61PN □ | | 270pF | 100 | ±5% | 0.7 |
| 34 | CL21C331JB61PN □ | | 330pF | 50 | ±5% | 0.7 |

※ □mark means packaging code. If you want to learn the code or quantity in detail, please see p80.

Product Lineup (Automotive Capacitors_COG)

| | Part Number | Size L × W (mm) | Capacitance | Rated Voltage (Vdc) | Capacitance Tolerance | Thickness Max. (mm) |
|----|------------------|-----------------|-------------|---------------------|-----------------------|---------------------|
| 35 | CL21C331JC61PN □ | 2.00×1.25 | 330pF | 100 | ±5% | 0.7 |
| 36 | CL21C471JBC1PN □ | | 470pF | 50 | ±5% | 0.95 |
| 37 | CL21C471JCC1PN □ | | 470pF | 100 | ±5% | 0.95 |
| 38 | CL21C561JBC1PN □ | | 560pF | 50 | ±5% | 0.95 |
| 39 | CL21C561JCC1PN □ | | 560pF | 100 | ±5% | 0.95 |
| 40 | CL21C681JBC1PN □ | | 680pF | 50 | ±5% | 0.95 |
| 41 | CL21C681JCC1PN □ | | 680pF | 100 | ±5% | 0.95 |
| 42 | CL21C821JBC1PN □ | | 820pF | 50 | ±5% | 0.95 |
| 43 | CL21C821JCC1PN □ | | 820pF | 100 | ±5% | 0.95 |
| 44 | CL21C102JBC1PN □ | | 1000pF | 50 | ±5% | 0.95 |
| 45 | CL21C102JCC1PN □ | | 1000pF | 100 | ±5% | 0.95 |
| 46 | CL21C102JCF1PN □ | | 1000pF | 100 | ±5% | 1.35 |
| 47 | CL21C122JBC1PN □ | | 1200pF | 50 | ±5% | 0.95 |
| 48 | CL21C152JBC1PN □ | | 1500pF | 50 | ±5% | 0.95 |
| 49 | CL21C182JBC1PN □ | | 1800pF | 50 | ±5% | 0.95 |
| 50 | CL21C222JBC1PN □ | | 2200pF | 50 | ±5% | 0.95 |
| 51 | CL21C272JBC1PN □ | | 2700pF | 50 | ±5% | 0.95 |
| 52 | CL21C332JBC1PN □ | | 3300pF | 50 | ±5% | 0.95 |
| 53 | CL21C392JBC1PN □ | | 3900pF | 50 | ±5% | 0.95 |
| 54 | CL21C472JBC1PN □ | | 4700pF | 50 | ±5% | 0.95 |
| 55 | CL21C562JBC1PN □ | | 5600pF | 50 | ±5% | 0.95 |
| 56 | CL21C102JBF1PN □ | | 1000pF | 50 | ±5% | 1.35 |
| 57 | CL21C122JBF1PN □ | | 1200pF | 50 | ±5% | 1.35 |
| 58 | CL21C152JBF1PN □ | | 1500pF | 50 | ±5% | 1.35 |
| 59 | CL21C182JBF1PN □ | | 1800pF | 50 | ±5% | 1.35 |
| 60 | CL21C222JBF1PN □ | | 2200pF | 50 | ±5% | 1.35 |
| 61 | CL21C272JBF1PN □ | | 2700pF | 50 | ±5% | 1.35 |
| 62 | CL21C332JBF1PN □ | | 3300pF | 50 | ±5% | 1.35 |
| 63 | CL21C392JBF1PN □ | | 3900pF | 50 | ±5% | 1.35 |
| 64 | CL21C472JBF1PN □ | | 4700pF | 50 | ±5% | 1.35 |
| 65 | CL21C562JBF1PN □ | | 5600pF | 50 | ±5% | 1.35 |
| 66 | CL21C682JBF1PN □ | | 6800pF | 50 | ±5% | 1.35 |
| 67 | CL21C822JBF1PN □ | | 8200pF | 50 | ±5% | 1.35 |
| 68 | CL21C103JBF1PN □ | | 10000pF | 50 | ±5% | 1.35 |

※ □mark means packaging code. If you want to learn the code or quantity in detail, please see p80.

Part Numbering System

General Capacitors

High Capacitance Capacitors

Super Small Size Capacitors

Medium-High Voltage Capacitors

Array Type Capacitors

Low ESL Capacitors

Reliability Test Condition

Premium Capacitors for Automotive Applications

Packaging Specification

Application Manual for Surface Mounting

Product Lineup (Automotive Capacitors_X7R)

| | Part Number | Size L×W (mm) | Capacitance | Rated Voltage (Vdc) | Capacitance Tolerance | Thickness Max. (mm) |
|----|------------------|---------------|-------------|---------------------|-----------------------|---------------------|
| 1 | CL10B221KC85PN □ | 1.60×0.80 | 0.22nF | 100 | ±10% | 0.90 |
| 2 | CL10B471KC85PN □ | | 0.47nF | 100 | ±10% | 0.90 |
| 3 | CL10B102KB85PN □ | | 1.0nF | 50 | ±10% | 0.90 |
| 4 | CL10B102KC85PN □ | | 1.0nF | 100 | ±10% | 0.90 |
| 5 | CL10B222KB85PN □ | | 2.2nF | 50 | ±10% | 0.90 |
| 6 | CL10B222KC85PN □ | | 2.2nF | 100 | ±10% | 0.90 |
| 7 | CL10B472KB85PN □ | | 4.7nF | 50 | ±10% | 0.90 |
| 8 | CL10B472KC85PN □ | | 4.7nF | 100 | ±10% | 0.90 |
| 9 | CL10B103KA85PN □ | | 10nF | 25 | ±10% | 0.90 |
| 10 | CL10B103KB85PN □ | | 10nF | 50 | ±10% | 0.90 |
| 11 | CL10B103KC85PN □ | | 10nF | 100 | ±10% | 0.90 |
| 12 | CL10B153KA85PN □ | | 15nF | 25 | ±10% | 0.90 |
| 13 | CL10B153KB85PN □ | | 15nF | 50 | ±10% | 0.90 |
| 14 | CL10B223KA85PN □ | | 22nF | 25 | ±10% | 0.90 |
| 15 | CL10B223KB85PN □ | | 22nF | 50 | ±10% | 0.90 |
| 16 | CL10B333KA85PN □ | | 33nF | 25 | ±10% | 0.90 |
| 17 | CL10B333KB85PN □ | | 33nF | 50 | ±10% | 0.90 |
| 18 | CL10B473KO85PN □ | | 47nF | 16 | ±10% | 0.90 |
| 19 | CL10B473KA85PN □ | | 47nF | 25 | ±10% | 0.90 |
| 20 | CL10B473KB85PN □ | | 47nF | 50 | ±10% | 0.90 |
| 21 | CL10B683KO85PN □ | | 68nF | 16 | ±10% | 0.90 |
| 22 | CL10B683KA85PN □ | | 68nF | 25 | ±10% | 0.90 |
| 23 | CL10B683KB85PN □ | | 68nF | 50 | ±10% | 0.90 |
| 24 | CL10B104KO85PN □ | | 100nF | 16 | ±10% | 0.90 |
| 25 | CL10B104KA85PN □ | | 100nF | 25 | ±10% | 0.90 |
| 26 | CL10B104KB85PN □ | | 100nF | 50 | ±10% | 0.90 |
| 27 | CL10B154KO84PN □ | | 150nF | 16 | ±10% | 0.90 |
| 28 | CL10B154KA84PN □ | | 150nF | 25 | ±10% | 0.90 |
| 29 | CL10B224KO84PN □ | | 220nF | 16 | ±10% | 0.90 |
| 30 | CL10B224KA84PN □ | | 220nF | 25 | ±10% | 0.90 |
| 31 | CL10B334KO84PN □ | | 330nF | 16 | ±10% | 0.90 |
| 32 | CL10B334KA84PN □ | | 330nF | 25 | ±10% | 0.90 |
| 33 | CL10B474KO84PN □ | | 470nF | 16 | ±10% | 0.90 |
| 34 | CL10B474KA84PN □ | | 470nF | 25 | ±10% | 0.90 |
| 1 | CL21B102KB65PN □ | 2.00×1.25 | 1.0nF | 50 | ±10% | 0.70 |
| 2 | CL21B102KC65PN □ | | 1.0nF | 100 | ±10% | 0.70 |
| 3 | CL21B222KB65PN □ | | 2.2nF | 50 | ±10% | 0.70 |
| 4 | CL21B222KC65PN □ | | 2.2nF | 100 | ±10% | 0.70 |
| 5 | CL21B472KB65PN □ | | 4.7nF | 50 | ±10% | 0.70 |
| 6 | CL21B472KC65PN □ | | 4.7nF | 100 | ±10% | 0.70 |
| 7 | CL21B103KB65PN □ | | 10nF | 50 | ±10% | 0.70 |
| 8 | CL21B103KC65PN □ | | 10nF | 100 | ±10% | 0.70 |
| 9 | CL21B153KB65PN □ | | 15nF | 50 | ±10% | 0.70 |
| 10 | CL21B153KC65PN □ | | 15nF | 100 | ±10% | 0.70 |
| 11 | CL21B223KB65PN □ | | 22nF | 50 | ±10% | 0.70 |
| 12 | CL21B223KC65PN □ | | 22nF | 100 | ±10% | 0.70 |
| 13 | CL21B333KBC5PN □ | | 33nF | 50 | ±10% | 0.95 |
| 14 | CL21B333KCC5PN □ | | 33nF | 100 | ±10% | 0.95 |

※ □mark means packaging code. If you want to learn the code or quantity in detail, please see p80.

Product Lineup (Automotive Capacitors_X7R)

| | Part Number | Size L×W (mm) | Capacitance | Rated Voltage (Vdc) | Capacitance Tolerance | Thickness Max. (mm) | |
|----|------------------|---------------|-------------|---------------------|-----------------------|---------------------|------|
| 15 | CL21B473KAC5PN □ | 2.00×1.25 | 47nF | 25 | ±10% | 0.95 | |
| 16 | CL21B473KBC5PN □ | | 47nF | 50 | ±10% | 0.95 | |
| 17 | CL21B473KCC5PN □ | | 47nF | 100 | ±10% | 0.95 | |
| 18 | CL21B683KAC5PN □ | | 68nF | 25 | ±10% | 0.95 | |
| 19 | CL21B683KBC5PN □ | | 68nF | 50 | ±10% | 0.95 | |
| 20 | CL21B683KCC5PN □ | | 68nF | 100 | ±10% | 0.95 | |
| 21 | CL21B104KOC5PN □ | | 100nF | 16 | ±10% | 0.95 | |
| 22 | CL21B104KAC5PN □ | | 100nF | 25 | ±10% | 0.95 | |
| 23 | CL21B104KBC5PN □ | | 100nF | 50 | ±10% | 0.95 | |
| 24 | CL21B104KBF5PN □ | | 100nF | 50 | ±10% | 1.35 | |
| 25 | CL21B104KCC5PN □ | | 100nF | 100 | ±10% | 0.95 | |
| 26 | CL21B104KCF5PN □ | | 100nF | 100 | ±10% | 1.35 | |
| 27 | CL21B154KOF4PN □ | | 150nF | 16 | ±10% | 1.35 | |
| 28 | CL21B154KAF4PN □ | | 150nF | 25 | ±10% | 1.35 | |
| 29 | CL21B154KBF4PN □ | | 150nF | 50 | ±10% | 1.35 | |
| 30 | CL21B224KOF4PN □ | | 220nF | 16 | ±10% | 1.35 | |
| 31 | CL21B224KAF4PN □ | | 220nF | 25 | ±10% | 1.35 | |
| 32 | CL21B224KBF4PN □ | | 220nF | 50 | ±10% | 1.35 | |
| 33 | CL21B334KOF4PN □ | | 330nF | 16 | ±10% | 1.35 | |
| 34 | CL21B334KAF4PN □ | | 330nF | 25 | ±10% | 1.35 | |
| 35 | CL21B334KBF4PN □ | | 330nF | 50 | ±10% | 1.35 | |
| 36 | CL21B474KOF4PN □ | | 470nF | 16 | ±10% | 1.35 | |
| 37 | CL21B474KAF4PN □ | | 470nF | 25 | ±10% | 1.35 | |
| 38 | CL21B474KBF4PN □ | | 470nF | 50 | ±10% | 1.35 | |
| 39 | CL21B684KOF4PN □ | | 680nF | 16 | ±10% | 1.35 | |
| 40 | CL21B684KAF4PN □ | | 680nF | 25 | ±10% | 1.35 | |
| 41 | CL21B105KOF4PN □ | | 1μF | 16 | ±10% | 1.35 | |
| 42 | CL21B105KAF4PN □ | | 1μF | 25 | ±10% | 1.35 | |
| 1 | CL31B104KBC5PN □ | | 3.20×1.60 | 100nF | 50 | ±10% | 1.00 |
| 2 | CL31B154KBP5PN □ | | | 150nF | 50 | ±10% | 1.25 |
| 3 | CL31B224KAC5PN □ | | | 220nF | 25 | ±10% | 1.00 |
| 4 | CL31B224KBP5PN □ | | | 220nF | 50 | ±10% | 1.25 |
| 5 | CL31B334KAC5PN □ | | | 330nF | 25 | ±10% | 1.00 |
| 6 | CL31B334KBH5PN □ | | | 330nF | 50 | ±10% | 1.80 |
| 7 | CL31B474KAC5PN □ | | | 470nF | 25 | ±10% | 1.00 |
| 8 | CL31B474KBH5PN □ | | | 470nF | 50 | ±10% | 1.80 |
| 9 | CL31B684KAP5PN □ | | | 680nF | 25 | ±10% | 1.25 |
| 10 | CL31B684KBH5PN □ | | | 680nF | 50 | ±10% | 1.80 |
| 11 | CL31B105KOP5PN □ | | | 1μF | 16 | ±10% | 1.25 |
| 12 | CL31B105KAP5PN □ | | | 1μF | 25 | ±10% | 1.25 |
| 13 | CL31B105KBH5PN □ | | | 1μF | 50 | ±10% | 1.80 |
| 14 | CL31B155KOH4PN □ | | | 1.5μF | 16 | ±10% | 1.80 |
| 15 | CL31B155KAH4PN □ | 1.5μF | | 25 | ±10% | 1.80 | |
| 16 | CL31B155KBH4PN □ | 1.5μF | | 50 | ±10% | 1.80 | |
| 17 | CL31B225KOH4PN □ | 2.2μF | | 16 | ±10% | 1.80 | |
| 18 | CL31B225KAH4PN □ | 2.2μF | | 25 | ±10% | 1.80 | |
| 19 | CL31B225KBH4PN □ | 2.2μF | | 50 | ±10% | 1.80 | |

※ □mark means packaging code. If you want to learn the code or quantity in detail, please see p80.

- Part Numbering System
- General Capacitors
- High Capacitance Capacitors
- Super Small Size Capacitors
- Medium-High Voltage Capacitors
- Array Type Capacitors
- Low ESL Capacitors
- Reliability Test Condition
- Premium Capacitors for Automotive Applications
- Packaging Specification
- Application Manual for Surface Mounting

Reliability Test Condition (Automotive Capacitors)

| No | Item | Performance | Test Condition | |
|----|-------------------------------------|--|---|--|
| 1 | Pre-and Post-Stress Electrical Test | - | | |
| 2 | High Temperature Exposure | Appearance | No abnormal exterior appearance Unpowered, 1000hrs@T=150°C Measurement at 24±2hrs after test conclusion | |
| | | Capacitance Change | CLASS I | Within ±2.5% or 0.25pF, (Whichever is larger) |
| | | | CLASS II | Within ±10% |
| | | Q | CLASS I | Capacitance ≥ 30pF : Q ≥ 1,000 < 30pF : Q ≥ 400 + 20 × C (C : Capacitance) |
| | | Tanδ | CLASS II | Rated Voltage ≥ 25V : 0.03 max ≥ 16V : 0.05 max ≥ 10V : 0.075 max |
| IR | | More than 10,000MΩ or 500MΩ × μF (Whichever is smaller) | | |
| 3 | Temperature Cycling | Appearance | No abnormal exterior appearance 1000Cycles Measurement at 24±2hrs after test conclusion | |
| | | Capacitance Change | CLASS I | Within ±2.5% or 0.25pF, (Whichever is larger) |
| | | | CLASS II | Within ±10% |
| | | Q | CLASS I | Capacitance ≥ 30pF : Q ≥ 1,000 < 30pF : Q ≥ 400 + 20 × C (C : Capacitance) |
| | | Tanδ | CLASS II | Rated Voltage ≥ 25V : 0.03 max ≥ 16V : 0.05 max ≥ 10V : 0.075max |
| IR | | More than 10,000MΩ or 500MΩ × μF (Whichever is smaller) | | |
| 4 | Destructive Physical Analysis | No defects or abnormalities | Per EIA 469 | |
| | | | | |
| 5 | Moisture Resistance | Appearance | No abnormal exterior appearance 10Cycles, t=24hrs/cycle Heat (25~65°C) and humidity (80~98%), Unpowered measurement at 24±2hrs after test conclusion | |
| | | Capacitance Change | CLASS I | Within ±2.5% or 0.25pF, (Whichever is larger) |
| | | | CLASS II | Within ±12.5% |
| | | Q | CLASS I | Capacitance ≥ 30pF : Q ≥ 350 < 10pF : Q ≥ 275+(5/2) × C < 10pF : Q ≥ 200+10 × C (C : Capacitance) |
| | | Tanδ | CLASS II | Rated Voltage ≥ 25V : 0.03 max ≥ 16V : 0.05 max ≥ 10V : 0.075max |
| IR | | More than 10,000MΩ or 500MΩ × μF (Whichever is smaller) | | |

| Step | Temperature(°C) | Time(min.) |
|------|-------------------------|------------|
| 1 | Min. operating Temp. ±2 | 15 ± 3 |
| 2 | 25 ± 2 | 1 |
| 3 | Max. operating Temp. ±2 | 15 ± 3 |
| 4 | 25 ± 2 | 1 |

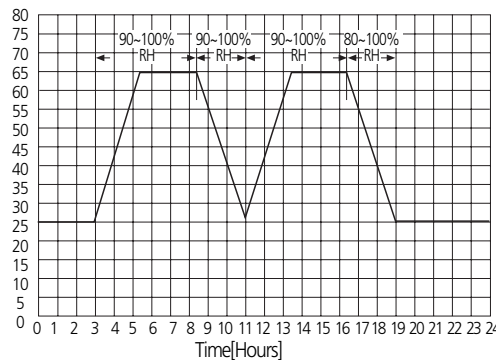

* For the more detail Specification, Please refer to the Samsung MLCC catalogue.

| No | Item | Performance | Test Condition | |
|----|---------------------------------|--|---|--|
| 6 | Biased Humidity | Appearance | No abnormal exterior appearance 1000hrs 85°C/85%RH, Rated Voltate and 1.3~1.5V, (add 100kohm resistor) Measurement at 24±2hrs after test conclusion The charge/discharge current is less than 50mA. | |
| | | Capacitance Change | CLASS I | Within ±2.5% or 0.25pF, (Whichever is larger) |
| | | | CLASS II | Within ±12.5% |
| | | Q | CLASS I | Capacitance ≥ 30pF : Q ≥ 200 < 30pF : Q ≥ 100 + (10/3) × C (C : Capacitance) |
| | | Tanδ | CLASS II | Rated Voltage ≥ 25V : 0.035 max ≥ 16V : 0.05 max ≥ 10V : 0.075max |
| IR | | More than 500MΩ or 25MΩ × μF (Whichever is Smaller) | | |
| 7 | High Temperature Operating Life | Appearance | No abnormal exterior appearance 1000hrs @ TA=125°C, 200% Rated Voltage, Measurement at 24±2hrs after test conclusion The charge/discharge current is less than 50mA. | |
| | | Capacitance Change | CLASS I | Within ±3.0% or 0.3pF, (Whichever is larger) |
| | | | CLASS II | Within ±12.5% |
| | | Q | CLASS I | Capacitance ≥ 30pF : Q ≥ 350 ≥ 10pF : Q ≥ 275+(5/2) × C < 10pF : Q ≥ 200+10 × C (C : Capacitance) |
| | | Tanδ | CLASS II | Rated Voltage ≥ 25V : 0.035 max ≥ 16V : 0.05 max ≥ 10V : 0.075max |
| IR | | More than 1,000MΩ or 50MΩ × μF (Whichever is smaller) | | |
| 8 | External Visual | No abnormal exterior appearance | Microscope (x10) | |
| 9 | Physical Dimensions | Within the specified dimensions | Using the calipers | |
| 10 | Mechanical Shock | Appearance | No abnormal exterior appearance Three shocks in each direction should be applied along 3 mutually perpendicular axes of the test specimen (18 shocks) | |
| | | Capacitance Change | CLASS I | Within ±2.5% or 0.25pF, (Whichever is larger) |
| | | | CLASS II | Within ±10% |
| | | Q | CLASS I | Capacitance ≥ 30pF : Q ≥ 1,000 < 30pF : Q ≥ 400 + 20 × C (C : Capacitance) |
| | | Tanδ | CLASS II | Rated Voltage ≥ 25V : 0.025 max ≥ 16V : 0.035 max ≥ 10V : 0.05max |
| IR | | More than 10,000MΩ or 500MΩ × μF (Whichever is smaller) | | |

| Peakvalue | Duration | Wave |
|-----------|----------|-----------|
| 1,500G | 0.5ms | Half sine |

* For the more detail Specification, Please refer to the Samsung MLCC catalogue.

Part Numbering System

General Capacitors

High Capacitance Capacitors

Super Small Size Capacitors

Medium-High Voltage Capacitors

Array Type Capacitors

Low ESL Capacitors

Reliability Test Condition

Premium Capacitors for Automotive Applications

Packaging Specification

Application Manual for Surface Mounting

| No | Item | | Performance | Test Condition | |
|----|---------------------------|--|---------------------------------|--|--|
| 11 | Vibration | Appearance | No abnormal exterior appearance | 5g's for 20min., 12cycles each of 3 orientations, Use 8" x5" PCB 0.031" Thick 7 secure points on one long side and 2 secure points at corners of opposite sides. Parts mounted within 2" from any secure point. Test from 10~2000 Hz. | |
| | | Capacitance Change | CLASS I | | Within ±2.5% or 0.25pF, (Whichever is larger) |
| | | | CLASS II | | Within ±10% |
| | | Q | CLASS I | | Capacitance ≥ 30pF : Q ≥ 1,000 < 30pF : Q ≥ 400+20×C (C : Capacitance) |
| | | Tanδ | CLASS II | | Rated Voltage ≥ 25V : 0.025 max ≥ 16V : 0.035 max ≥ 10V : 0.05max |
| IR | | More than 10,000MΩ or 500MΩ × μF (Whichever is smaller) | | | |
| 12 | Resistance to Solder Heat | Appearance | No abnormal exterior appearance | Solder pot : 260 ± 5°C, 10 ± 1sec. | |
| | | Capacitance Change | CLASS I | | Within ±2.5% or 0.25pF, (Whichever is larger) |
| | | | CLASS II | | Within ±10% |
| | | Q | CLASS I | | Capacitance ≥ 30pF : Q ≥ 1,000 < 30pF : Q ≥ 400+20×C (C : Capacitance) |
| | | Tanδ | CLASS II | | Rated Voltage ≥ 25V : 0.025 max ≥ 16V : 0.035 max ≥ 10V : 0.05max |
| IR | | More than 10,000MΩ or 500MΩ × μF (Whichever is smaller) | | | |
| 13 | Thermal Shock | Appearance | No abnormal exterior appearance | -55°C/+125°C Note: Number of cycles required - 300, Maximum transfer time-20 sec, Dwell time-15min. Air-Air | |
| | | Capacitance Change | CLASS I | | Within ±2.5% or 0.25pF, (Whichever is larger) |
| | | | CLASS II | | Within ±10% |
| | | Q | CLASS I | | Capacitance ≥ 30pF : Q ≥ 1,000 < 30pF : Q ≥ 400+20×C (C : Capacitance) |
| | | Tanδ | CLASS II | | Rated Voltage ≥ 25V : 0.025 max ≥ 16V : 0.035 max ≥ 10V : 0.05max |
| IR | | More than 10,000MΩ or 500MΩ × μF (Whichever is smaller) | | | |
| 14 | ESD | Appearance | No abnormal exterior appearance | AEC-Q200-002 | |
| | | Capacitance Change | CLASS I | | Within ±2.5% or 0.25pF, (Whichever is larger) |
| | | | CLASS II | | Within ±10% |
| | | Q | CLASS I | | Capacitance ≥ 30pF : Q ≥ 1,000 < 30pF : Q ≥ 400+20×C (C : Capacitance) |
| | | Tanδ | CLASS II | | Rated Voltage ≥ 25V : 0.025 max ≥ 16V : 0.035 max ≥ 10V : 0.05max |
| IR | | More than 10,000MΩ or 500MΩ × μF (Whichever is smaller) | | | |

* For the more detail Specification, Please refer to the Samsung MLCC catalogue.

| No | Item | | Performance | Test Condition | | | | | | | | | | | | | | | | | | | |
|-------------------------|--|---|---|--|---|-----------|-----------------|-----------|---|--------|---|---|-------------------------|--------|---|--------|---|---|-------------------------|--------|---|--------|---|
| 15 | Solderability | | 95% of the terminations is to be soldered evenly and continuously | a) Preheat at 155°C for 4 hours, Immerse in solder for 5s at 235 ± 5°C b) Steam aging for 8 hours, Immerse in solder for 5s at 235 ± 5°C c) Steam aging for 8 hours, Immerse in solder for 120s at 260 ± 5°C solder : a solution ethanol and rosin | | | | | | | | | | | | | | | | | | | |
| 16 | Electrical Characterization | Capacitance | Within specified tolerance | The Capacitance /D.F. should be measured at 25°C, I.R. should be measured with a DC voltage not exceeding Rated Voltage @25°C, @125°C for 60~120 sec. Dielectric Strength : 250% of the rated voltage for 1~5 seconds The charge/discharge current is less than 50mA. | | | | | | | | | | | | | | | | | | | |
| | | Q | CLASS I | | Capacitance ≥ 30pF : Q ≥ 1,000 < 30pF : Q ≥ 400+20×C (C : Capacitance) | | | | | | | | | | | | | | | | | | |
| | | | CLASS II | | Rated Voltage ≥ 25V : 0.025 max ≥ 16V : 0.035 max ≥ 10V : 0.05max | | | | | | | | | | | | | | | | | | |
| | | IR@25°C | CLASS I | | More than 100,000MΩ or 1,000MΩ × μF (Whichever is smaller) | | | | | | | | | | | | | | | | | | |
| | | | CLASS II | | More than 10,000MΩ or 500MΩ × μF (Whichever is smaller) | | | | | | | | | | | | | | | | | | |
| | | IR@125°C | CLASS I | | More than 10,000MΩ or 100MΩ × μF (Whichever is smaller) | | | | | | | | | | | | | | | | | | |
| CLASS II | More than 1,000MΩ or 10MΩ × μF (Whichever is smaller) | | | | | | | | | | | | | | | | | | | | | | |
| Dielectric Strength | | No dielectric breakdown or mechanical breakdown | | | | | | | | | | | | | | | | | | | | | |
| 17 | Board Flex | Appearance | No abnormal exterior appearance | Bending to the limit for 5 seconds Limit : Class I - 3mm Class II - 2mm | | | | | | | | | | | | | | | | | | | |
| | | Capacitance Change | CLASS I | | Within ±5.0% or 0.5pF, (Whichever is larger) | | | | | | | | | | | | | | | | | | |
| CLASS II | Within ±10% | | | | | | | | | | | | | | | | | | | | | | |
| 18 | Terminal Strength(SMD) | Appearance | No abnormal exterior appearance | 18N, for 60 ± 1 sec. * 0603(1608) -10N, 0402(1005) -2N | | | | | | | | | | | | | | | | | | | |
| | | Capacitance Change | CLASS I | | Within ±2.5% or 0.25pF, (Whichever is larger) | | | | | | | | | | | | | | | | | | |
| CLASS II | Within ±10% | | | | | | | | | | | | | | | | | | | | | | |
| 19 | Beam Load | | Destruction value should be exceed Chip Length ≤ 2.5mm a) Chip Thickness > 0.5mm : 20N b) Chip Thickness ≤ 0.5mm : 8N Chip Length ≥ 3.2mm a) Chip Thickness ≥ 1.25mm : 54.5N b) Chip Thickness < 1.25mm : 15N | Beam speed Chip Length ≤ 2.5mm, 0.5 ± 0.05mm/sec Chip Length ≥ 3.2mm, 2.5 ± 0.25mm/sec | | | | | | | | | | | | | | | | | | | |
| 20 | Capacitance Temperature Characteristics | Capacitance Change | CLASS I | 0 ± 30 ppm/°C | <table border="1"> <thead> <tr> <th>Step</th> <th>Temperature(°C)</th> <th>Time(min)</th> </tr> </thead> <tbody> <tr> <td>1</td> <td>25 ± 2</td> <td>1</td> </tr> <tr> <td>2</td> <td>Min. Operating Temp. ±2</td> <td>15 ± 3</td> </tr> <tr> <td>3</td> <td>25 ± 2</td> <td>1</td> </tr> <tr> <td>4</td> <td>Max. Operating Temp. ±2</td> <td>15 ± 3</td> </tr> <tr> <td>5</td> <td>25 ± 2</td> <td>1</td> </tr> </tbody> </table> | Step | Temperature(°C) | Time(min) | 1 | 25 ± 2 | 1 | 2 | Min. Operating Temp. ±2 | 15 ± 3 | 3 | 25 ± 2 | 1 | 4 | Max. Operating Temp. ±2 | 15 ± 3 | 5 | 25 ± 2 | 1 |
| | | | Step | Temperature(°C) | | Time(min) | | | | | | | | | | | | | | | | | |
| | | 1 | 25 ± 2 | 1 | | | | | | | | | | | | | | | | | | | |
| | | 2 | Min. Operating Temp. ±2 | 15 ± 3 | | | | | | | | | | | | | | | | | | | |
| 3 | 25 ± 2 | 1 | | | | | | | | | | | | | | | | | | | | | |
| 4 | Max. Operating Temp. ±2 | 15 ± 3 | | | | | | | | | | | | | | | | | | | | | |
| 5 | 25 ± 2 | 1 | | | | | | | | | | | | | | | | | | | | | |
| CLASS II | Within ±15% | | | | | | | | | | | | | | | | | | | | | | |
| Temperature Coefficient | CLASS I | 0 ± 30 ppm/°C | | | | | | | | | | | | | | | | | | | | | |
| | CLASS II | Within ±0.2% or 0.05pF, (Whichever is larger) | | | | | | | | | | | | | | | | | | | | | |

* For the more detail Specification, Please refer to the Samsung MLCC catalogue.

Part Numbering System

General Capacitors

High Capacitance Capacitors

Super Small Size Capacitors

Medium-High Voltage Capacitors

Array Type Capacitors

Low ESL Capacitors

Reliability Test Condition

Premium Capacitors for Automotive Applications

Packaging Specification

Application Manual for Surface Mounting

Cardboard Paper Tape(4mm)

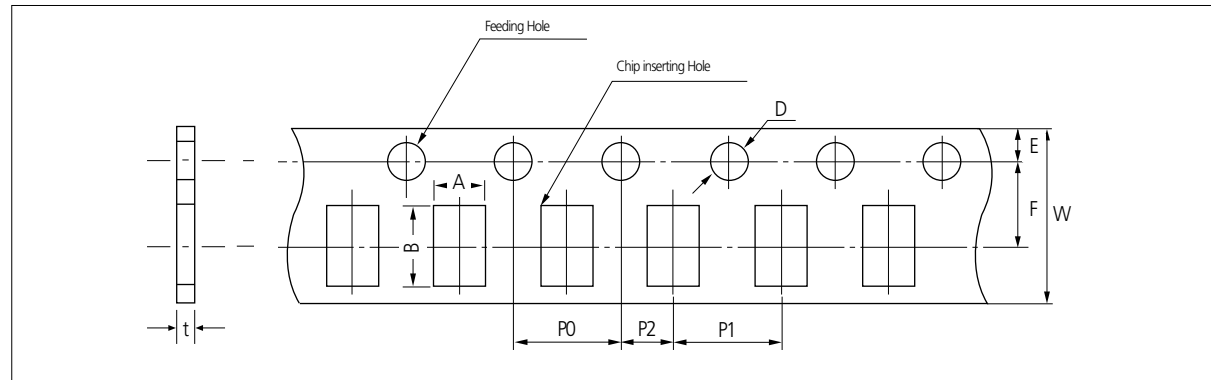

Unit: inch(mm)

| Symbol Type | | A | B | W | F | E | P1 | P2 | P0 | D | t |
|-------------|----------------------------|-------------|-------------|-------------|--------------|--------------|-------------|--------------|-------------|-----------------|--------------|
| Dimension | 0504 (1410) | 1.3 ±0.2 | 1.7 ±0.2 | 8.0 ±0.3 | 3.5 ±0.05 | 1.75 ±0.1 | 4.0 ±0.1 | 2.0 ±0.05 | 4.0 ±0.1 | Ø1.5 +0.1/-0 | 1.1 Below |
| | 0603 0306 (1608) (0816) | 1.1 ±0.2 | 1.9 ±0.2 | | | | | | | | |
| | 0805 0508 (2012) (1220) | 1.6 ±0.2 | 2.4 ±0.2 | | | | | | | | |
| | 1206 0612 (3216) (1632) | 2.0 ±0.2 | 3.6 ±0.2 | | | | | | | | |

Cardboard Paper Tape(2mm)

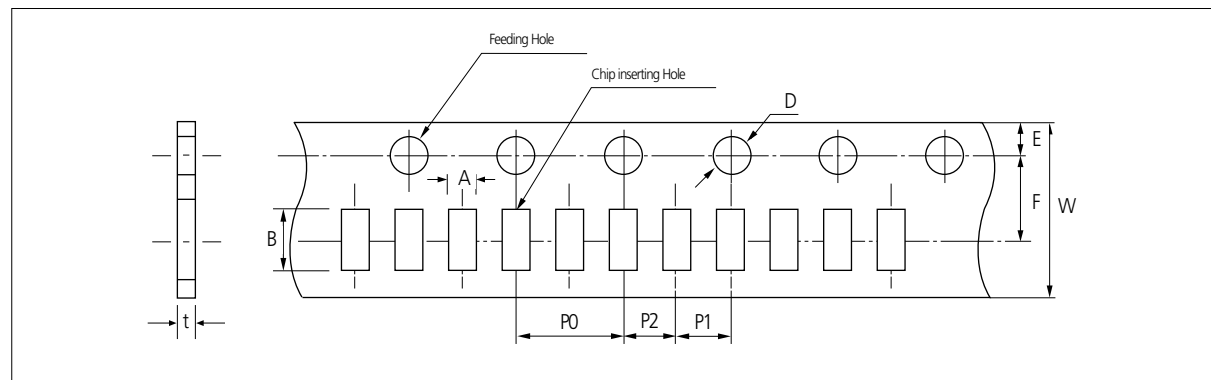

Unit: inch(mm)

| Symbol Type | | A | B | W | F | E | P1 | P2 | P0 | D | t |
|-------------|-----------------|---------------|---------------|-------------|--------------|---------------|--------------|--------------|-------------|--------------------|---------------|
| Dimension | 01005 (0402) | 0.26 ±0.03 | 0.46 ±0.03 | 8.0 ±0.3 | 3.5 ±0.05 | 1.75 ±0.05 | 2.0 ±0.05 | 2.0 ±0.05 | 4.0 ±0.1 | Ø1.550 ±0.02 | 0.26 ±0.03 |
| | 0201 (0603) | 0.38 ±0.03 | 0.68 ±0.03 | | | 1.75 ±0.1 | 2.0 ±0.05 | 2.0 ±0.05 | 4.0 ±0.1 | Ø1.5 +0.1/-0.03 | 0.37 ±0.03 |
| | 0402 (1005) | 0.62 ±0.04 | 1.12 ±0.04 | | | 0.6 ±0.05 | | | | | |

Embossed Plastic Tape

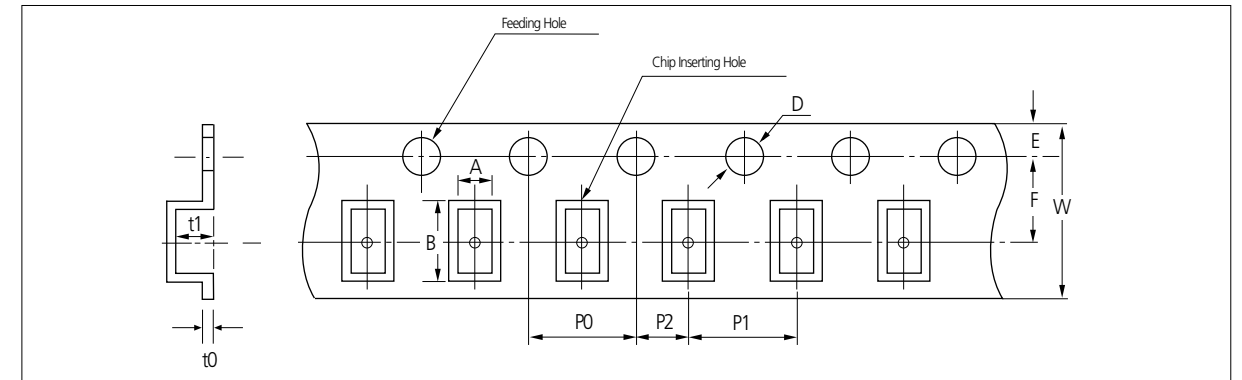

Unit: inch(mm)

| Symbol Type | | A | B | W | F | E | P1 | P2 | P0 | D | t1 | t0 |
|-------------|----------------------------|---------------|--------------|-------------|--------------|--------------|--------------|---------------|-------------|-----------------|------------|--------------|
| Dimension | 0603 (1608) | 1.05 ±0.15 | 1.9 ±0.15 | 8.0 ±0.3 | 3.5 ±0.05 | 1.75 ±0.1 | 4.0 ±0.1 | 2.0 ±0.05 | 4.0 ±0.1 | Ø1.5 +0.1/-0 | 2.8 max | 0.6 BELOW |
| | 0805 (2012) | 1.45 ±0.2 | 2.3 ±0.2 | | | | | | | | | |
| | 1206 0612 (3216) (1632) | 1.9 ±0.2 | 3.5 ±0.2 | | | | | | | | | |
| | 1210 (3225) | 2.8 ±0.2 | 3.6 ±0.2 | | | | 8.0 ±0.1 | 3.8 max | | | | |
| | 1808 (4520) | 2.3 ±0.2 | 4.9 ±0.2 | | | | | | | | | |
| | 1812 (4532) | 3.6 ±0.2 | 4.9 ±0.2 | | | | 12.0 ±0.3 | 5.60 ±0.05 | | | | |
| | 2220 (5750) | 5.5 ±0.2 | 6.2 ±0.2 | | | | | | | | | |

Peeling off of Cover Tape

- 5 g.f ≤ Peel off force ≤ 70 g.f

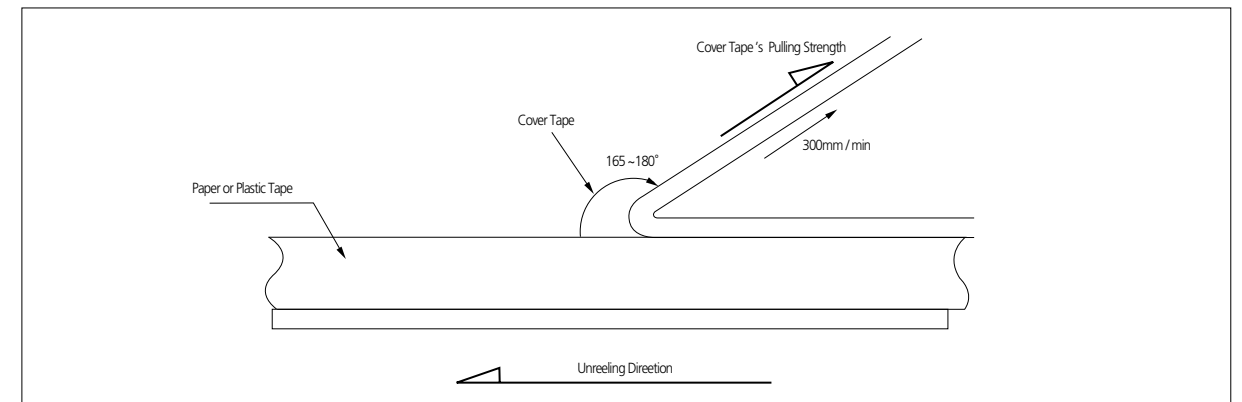

Part Numbering System

General Capacitors

High Capacitance Capacitors

Super Small Size Capacitors

Medium-High Voltage Capacitors

Array Type Capacitors

Low ESL Capacitors

Reliability Test Condition

Premium Capacitors for Automotive Applications

Packaging Specification

Application Manual for Surface Mounting

Taping Size

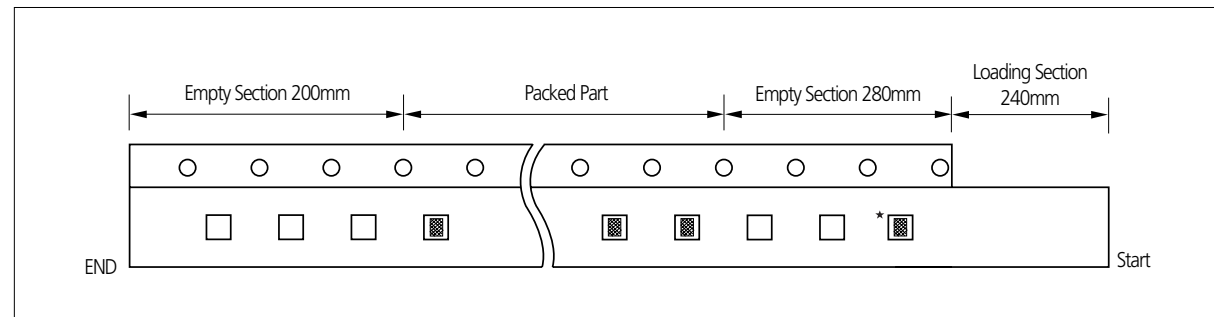

• The chip is only use for identifying the label and packaged products. Please don't use the chip.

Unit: kpcs

| Size | T code | Quantity & Packing Code | | | | | | | | |
|-------------|------------|-------------------------|------------|-------------|-------------|-------------|--------------|------------|-------------|-------------|
| | | Paper Type | | | | | Plastic Type | | | |
| | | C (7"reel) | H (7"reel) | O (10"reel) | D (13"reel) | L (13"reel) | E (7"reel) | G (7"reel) | F (13"reel) | S (10"reel) |
| 01005(0402) | 2 | 20 | - | - | - | - | - | - | - | - |
| 0201(0603) | 3 | 10 | 15 | 30 | 50 | - | - | - | - | - |
| 0402(1005) | 3 | 10 | 15 | 30 | 50 | - | - | - | - | - |
| | 5 | 10 | - | 30 | 50 | - | - | - | - | - |
| 0504(1410) | 8 | 4 | - | 10 | 10 | 15 | - | - | - | - |
| 0603(1608) | 5 | 4 | - | 30 | 50 | - | - | - | - | - |
| | 8 | 4 | - | 10 | 10 | 15 | - | - | - | - |
| 0604(1610) | D | - | - | - | - | 3 | - | 10 | 6 | - |
| 0805(2012) | A, C | 4 | - | 10 | 10 | 15 | - | - | - | - |
| | E, F, Q | - | - | - | - | - | 2 | 3 | 10 | 6 |
| 1206(3216) | C | 4 | - | 10 | 10 | 15 | - | - | - | - |
| | E, F, P | - | - | - | - | - | 2 | 3 | 10 | 6 |
| | H | - | - | - | - | - | 2 | - | 8 | 4 |
| 1210(3225) | 9, D, C, O | - | - | - | - | - | 2 | - | 10 | - |
| | E, F, M | - | - | - | - | - | 2 | - | 10 | - |
| | H, T | - | - | - | - | - | 2 | - | 8 | 4 |
| | I, U | - | - | - | - | - | 2 | - | 4 | - |
| | J, V | - | - | - | - | - | 1 | - | 4 | - |
| 1808(4520) | S | - | - | - | - | - | 2 | - | 8 | - |
| | F | - | - | - | - | - | 2 | - | - | - |
| 1812(4532) | F, H, I | - | - | - | - | - | 1 | - | 4 | - |
| | L, J | - | - | - | - | - | - | - | 2 | - |
| 2220(5750) | H, I, J | - | - | - | - | - | - | - | 2 | - |

Reel Dimensions

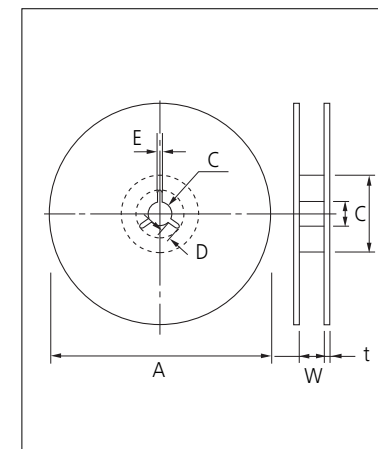

Unit: mm

| Symbol | Tape Width | A | B | C | D |
|----------|------------|-----------|----------|---------|-------|
| 7" Reel | 8mm | Ø180+0/-3 | Ø60+1/-0 | Ø13±0.3 | 4±0.2 |
| | 12mm | Ø180+0/-3 | Ø60+1/-0 | Ø13±0.3 | 4±0.2 |
| 10" Reel | 8mm | Ø258+0/-3 | Ø80+1/-0 | Ø13±0.3 | 4±0.2 |
| | 12mm | Ø258+0/-3 | Ø80+1/-0 | Ø13±0.3 | 4±0.2 |
| 13" Reel | 8mm | Ø330±2.0 | Ø80±1.0 | Ø13±0.3 | 4±0.2 |
| | 12mm | Ø330±2.0 | Ø80±1.0 | Ø13±0.3 | 4±0.2 |

| Symbol | Tape Width | E | W | t |
|----------|------------|---------|--------|---------|
| 7" Reel | 8mm | 2.0±0.5 | 9±0.5 | 1.2±0.2 |
| | 12mm | 2.0±0.5 | 13±0.5 | 1.2±0.2 |
| 10" Reel | 8mm | 2.0±0.5 | 9±0.5 | 1.8±0.2 |
| | 12mm | 2.0±0.5 | 13±0.5 | 1.8±0.2 |
| 13" Reel | 8mm | 2.0±0.5 | 9±0.5 | 2.2±0.2 |
| | 12mm | 2.0±0.5 | 13±0.5 | 2.2±0.2 |

Bulk Case Packaging

- Bulk case packaging can reduce the stock space and transportation costs.
- The bulk feeding system can increase the productivity.
- It can eliminate the components loss.

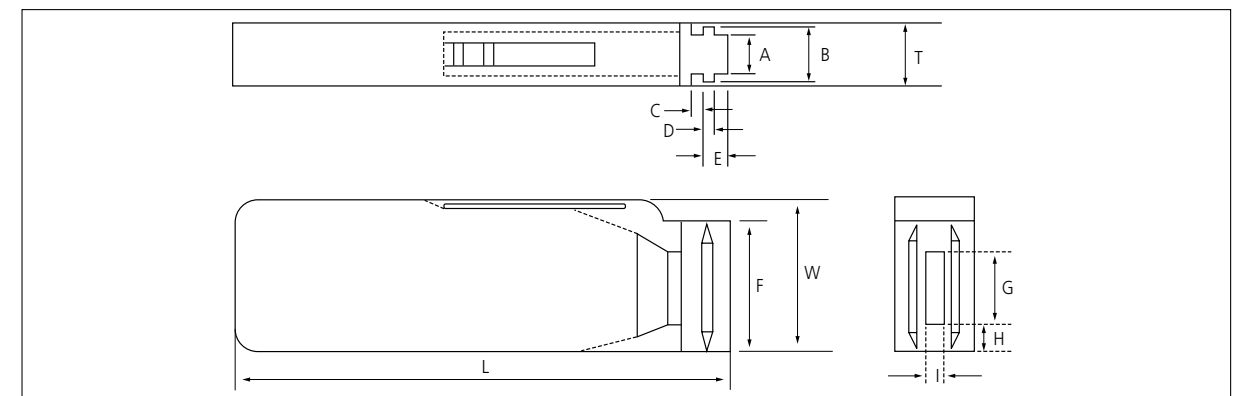

Unit: mm

| Symbol | A | B | T | C | D | E |
|-----------|---------|---------|--------|------------|----------|------------|
| Dimension | 6.8±0.1 | 8.8±0.1 | 12±0.1 | 1.5+0.1/-0 | 2+0/-0.1 | 3.0+0.2/-0 |

| Symbol | F | W | G | H | L | I |
|-----------|-------------|-----------|---------|--------|---------|--------|
| Dimension | 31.5+0.2/-0 | 36+0/-0.2 | 19±0.35 | 7±0.35 | 110±0.7 | 5±0.35 |

• QUANTITY

Unit: inch(mm) and pcs

| Size | 0402(1005) | 0603(1608) | 0805(2012) | |
|----------|------------|------------------|------------|-----------------|
| | | | T=0.65mm | T=0.85mm |
| Quantity | 50,000 | 10,000 or 15,000 | 10,000 | 5,000 or 10,000 |

Part Numbering System

General Capacitors

High Capacitance Capacitors

Super Small Size Capacitors

Medium-High Voltage Capacitors

Array Type Capacitors

Low ESL Capacitors

Reliability Test Condition

Premium Capacitors for Automotive Applications

Packaging Specification

Application Manual for Surface Mounting

1. Storage of products

1-1. Storage Environment

Tape packing materials are designed to withstand long-term storage, but they will degrade more rapidly in the presence of high temperature or high humidity. Therefore, the products must be stored in an ambient 5~40°C with a relative humidity of 20~70%. Allowable storage period is within 6 months from the outgoing date of delivery.

1-2. Corrosive Gases

Since sulfur and chlorine may degrade the solderability of the end termination, it is important to store the capacitors in an environment free of these gases

1-3. Temperature Fluctuations

Since dew condensation may occur by the differences in temperature when the products are taken out of storage, it is important to maintain a temperature-controlled environment.

2. Design of Solder Land Pattern

When designing printed circuit boards, the shape and size of the solder lands must allow for the proper amount of solder on the capacitor. The amount of solder at the end terminations has a direct effect on the probability that the chip will crack. The greater amount of solder, the larger amount of stress on the chip, and the more likely that it will break. Use the following illustrations as guidelines for proper Solder land design.

Recommendation of solder Land Shape and Size

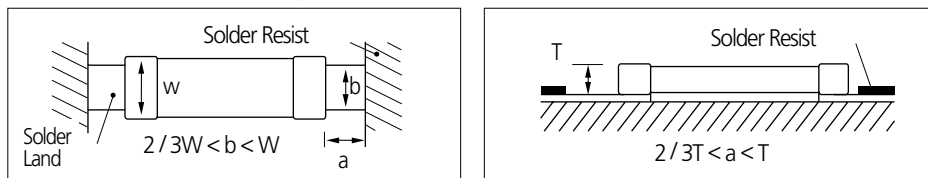

3. Adhesives

MLCCs generally require the use of an adhesive to position the chips to the circuit board prior to soldering.

3-1. Requirements for Adhesives

- They must have enough adhesion so that the chips will not fall off or move during the handling of the circuit board.
- They must maintain their adhesive strength when exposed to soldering temperatures.
- They should not spread or run when applied to the circuit board.
- They should have a long pot life.
- They should harden quickly.
- They should not corrode the circuit board or chip material.
- They should be a good insulator.
- They should be non-toxic, and not produce harmful gases, nor be harmful when touched.

3-2. Application Method

It is important to use the proper amount of adhesive. Too little will cause poor adhesion to the circuit board, and too much may strain the conductor pattern, thereby causing defective soldering. The following illustrations show the proper quantity of adhesive.

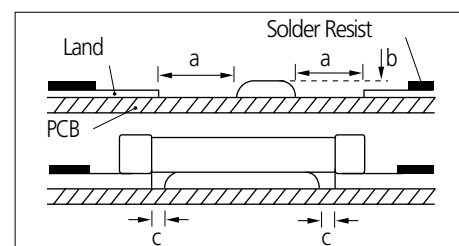

Unit: mm

| Type | 21 | 31 |
|------|----------|----------|
| a | 0.2min | 0.2min |
| b | 70~100μm | 70~100μm |
| c | >0 | >0 |

3-3. Adhesive hardening Characteristics

To prevent oxidation of the terminations, the adhesive must harden at 160°C or less, within 2 minutes or less.

4. Mounting

4-1. Mounting Head Pressure

Excessive pressure will cause chip capacitors to crack. The pressure between nozzle and chip capacitor will be 300g maximum during mounting.

4-2. Bending Stress

Bending of printed circuit board by mounting head when double-sided circuit boards are used, chip capacitors first are mounted and soldered onto one side of the board. When the capacitors are mounted onto the other side, it is important to support the board as shown in the illustration. If the circuit board is not supported, it may bend, causing the already-installed capacitors to crack.

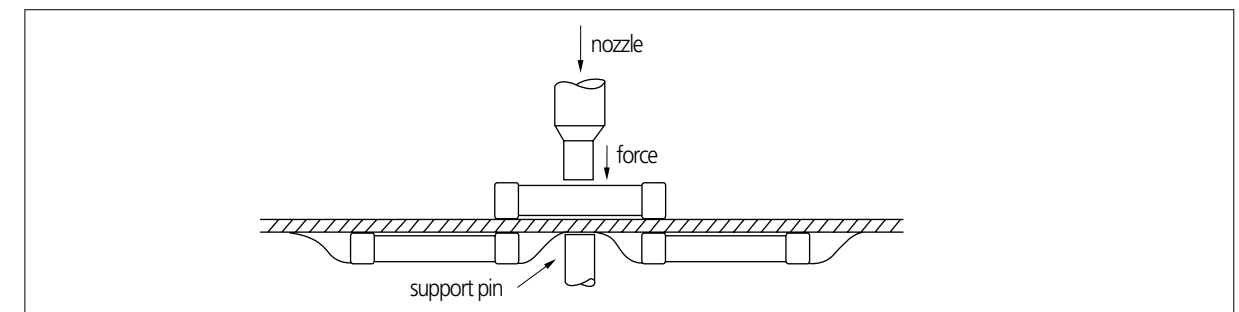

5. Flux

Although highly-activated flux gives better solderability, substances which increase activity may also degrade the insulation of the chip capacitors. To avoid such degradation, it is recommended that a mildly activated rosin flux (less than 0.2% chlorine) be used.

6. Soldering

Since a multilayer ceramic chip capacitor comes into direct contact with melted solder during soldering, it is exposed to potentially mechanical stress caused by the sudden temperature change. The capacitor may also be subject to silver migration, and to contamination by the flux. Because of these factors, soldering technique is critical.

6-1. Soldering Methods

| Method | Classification | |
|------------------|--------------------------------|---|
| Reflow soldering | · Overall heating | · Infrared rays · Hot plate · VPS (Vapor phase) |
| | · Local heating | · Air heater · Laser · Light beam |
| Flow Soldering | · Single wave · Double wave | |

6-2. Soldering Profile

To avoid the crack problem by sudden temperature change, follow the temperature profile in the adjacent graph.

Part Numbering System

General Capacitors

High Capacitance Capacitors

Super Small Size Capacitors

Medium-High Voltage Capacitors

Array Type Capacitors

Low ESL Capacitors

Reliability Test Condition

Premium Capacitors for Automotive Applications

Packaging Specification

Application Manual for Surface Mounting

6-2-1 Pb-Free (Sn 100%) Plating

REFLOW SOLDERING

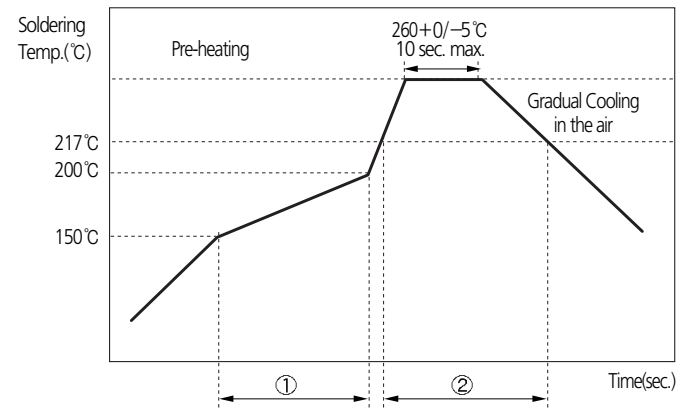

| Soldering Temp. (°C) | Pre-heating Time (①, sec.) | Soldering Time (②, sec.) |
|----------------------|----------------------------|--------------------------|
| 260+0/-5°C | 60~120 | 60~150 |

FLOW SOLDERING

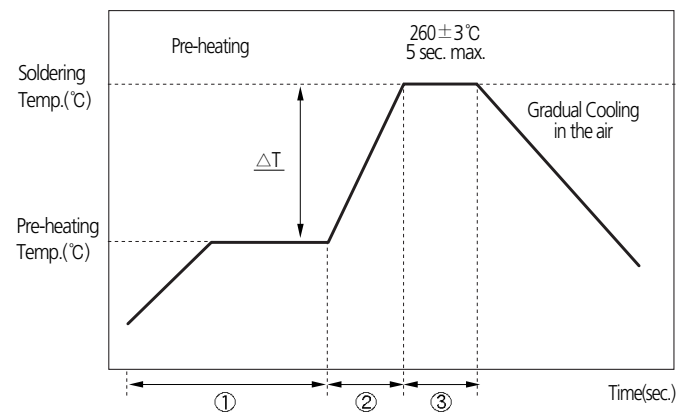

| ΔT(°C) | Soldering Temp. (°C) | Pre-heating Time (①+②, sec.) | Soldering Time (③, sec.) |
|--------------------------------|----------------------|------------------------------|--------------------------|
| ≤ 150 (1206 and below size) | 260±3 | ≥ 120 | ≤ 5 |

SOLDER IRON(Hand Soldering)

| Variation of Temp.(°C) | Soldering Temp(°C) | Pre-heating Time(sec.) | Soldering Time(sec.) | Cooling Time(sec.) | Condition of Iron Facilities | | |
|------------------------|--------------------|------------------------|----------------------|--------------------|------------------------------|--------------|----------------|
| | | | | | Wattage | Tip Diameter | Soldering Time |
| ΔT≤130 | 300±10°Cmax. | ≥ 60 sec. | ≤ 4 sec. | - | 20W max. | 3mm max. | 4 sec max. |

※ Caution - Iron tip should not contact with ceramic body directly

6-3. Manual Soldering

Manual soldering can pose a great risk of creating thermal cracks in chip capacitors. The hot soldering iron tip comes into direct contact with the end terminations, and operator's carelessness may cause the tip of the soldering iron to come into direct contact with the ceramic body of the capacitor. Therefore the soldering iron must be handled carefully, and close attention must be paid to the selection of the soldering iron tip and to temperature control of the tip.

6-4. Amount of Solder

| | | |
|-------------------|--|--|
| Too much Solder | | Cracks tend to occur due to large stress. |
| Not enough solder | | Weak holding force may cause bad connections or detaching of the capacitor |

6-5. Cooling

Natural cooling using air is recommended. If the chips are dipped into solvent for cleaning, the temperature difference (ΔT) must be less than 100°C

6-6. Cleaning

If rosin flux is used, cleaning usually is unnecessary. When strongly activated flux is used, chlorine in the flux may dissolve into some types of cleaning fluids, thereby affecting the chip capacitors. This means that the cleaning fluid must be carefully selected, and should always be new.

7. Notes for Separating Multiple, Shared PC Boards

A multi-PC board is separated into many individual circuit boards after soldering has been completed. If the board is bent or distorted at the time of separation, cracks may occur in the chip capacitors. Carefully choose a separation method that minimizes the bending of the circuit board.

- Part Numbering System
- General Capacitors
- High Capacitance Capacitors
- Super Small Size Capacitors
- Medium-High Voltage Capacitors
- Array Type Capacitors
- Low ESL Capacitors
- Reliability Test Condition
- Premium Capacitors for Automotive Applications
- Packaging Specification
- Application Manual for Surface Mounting