

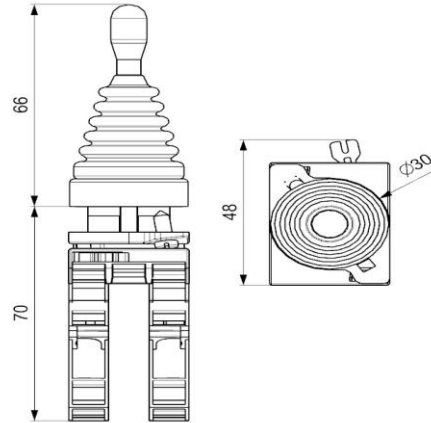

EMAS ELEKTROTEKNIK MAKİNA
SANAYİ VE TİCARET A.Ş

Ziya Gökalp Mah. İkitelli Organize Sanayi
Bölgesi Atatürk Bulvarı No:50 34490
Başakşehir / İstanbul / TÜRKİYE
Telefon : +90 212 549 22 52
Faks : +90 212 549 25 80
Web : www.emasas.com.tr

Artikelnummer/Order Code: CM707DJ41



Produktinformationen/Product information

Elektrische Informationen	Wert
Anwendungsbereich <i>Range of Use</i>	AC15
Schaltspannung U_e <i>Operating voltage U_e</i>	230 V/AC
Operating frequency f <i>Betriebsfrequenz f</i>	50 Hz
Schaltstrom I_e <i>Operating current I_e</i>	4 A
Isolationsspannung U_i <i>Insulation voltage U_i</i>	300 V
Stoßspannungsfestigkeit U_{imp} <i>Stroke resistance voltage U_{imp}</i>	2,5 kV
Durchschlagfestigkeit <i>Dielectrical Strength</i>	1.500 V/AC

Technische Informationen	Wert
Temperaturbereich <i>Operating temperature</i>	-5 °C – 40 °C
Schutzgrad <i>Protection degree</i>	IP65
Mechanische Lebensdauer <i>Mechanical life</i>	500.000 Zyklen
Elektrische Lebensdauer <i>Electrical life</i>	100.000 Zyklen
Schalzhäufigkeit <i>switching frequency</i>	ohne Last 3.000 pro Std. Vollast 1.800 pro Std.
Anziedrehmoment Kontaktblock <i>Contact block tightening torque</i>	0,6 – 0,8 Nm
Querschnitt Verbindungskabel <i>Connection wire profile</i>	min. 1 x 0,5 mm ² max. 2 x 2,5 mm ²

Beschreibung:

Möglichkeit mit Platinen und Anstecker Unterbauten aufzustellen
(Opportunity of positioning with plates and Badge Bases)

- 4 Pos.
- Metallgehäuse
(metallic housing)
- Anschlussklemme mit Fingerschutz
(terminals with finger protection)
- Feuerfestes Kontaktblockgehäuse
(fireproof plastic contact block body)
- Sequenzielles verknüpfbares Gehäuse und Kontaktblock nach dem Legoprinzip
(sequential connectable body and contact blocks after lego magic)
- Abschirmender Kabeleinlass für höchste Sicherheit
(Protective cable inlet tips enabling maximum safety)
- Unterlegscheibe
(screw washers)

