

Interface Module / Electronics Enclosures

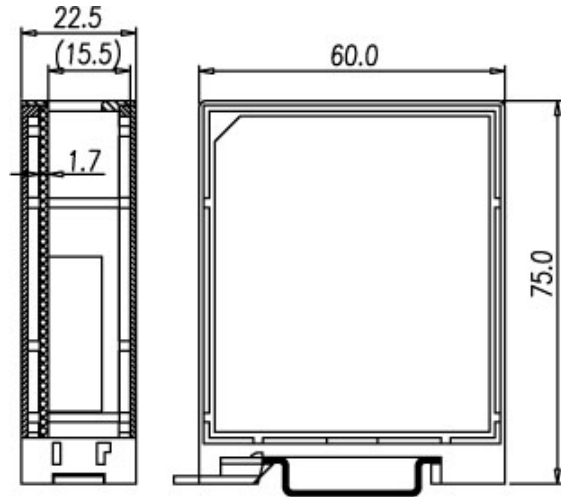

**DMUG-22**



Technical Data	
Pole Size	14
PCB Set	1
Terminal Block	5EHDR-04.08P 5ESDV-04-.08P
Solid wire(AWG)	28~12
Stranded wire(AWG)	28~12
Wire strip length	7~8mm

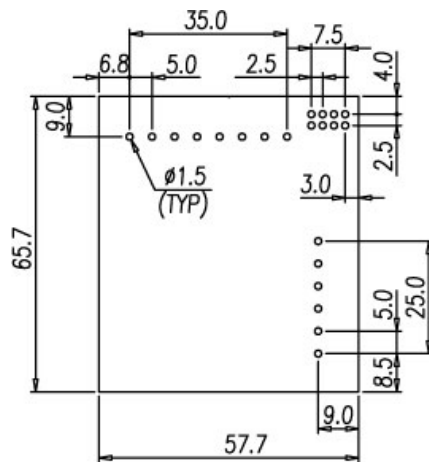

TEL: +886-2-2908-0614

FAX: +886-2-2908-8549

E-mail: [infor@dinkle.com.tw](mailto:infor@dinkle.com.tw)