

ITEM NO	BODY	PANEL	O-RING	RUBBER FEET	SCREW	EXTERNAL DIMENSION(mm) AxBXC
ALUG704GD060	ALUMINIUM EXTRUSION 6063/ GOLDEN ANODIZED(PANTONE 4675C)	DIE-CAST ALUMINIUM ADC-12 /PAINTED BLACK(RAL9005)	Ø6X0.5 mm MATERIAL:PC COLOR:CLEAR	Ø12X5 mm MATERIAL:RUBBER (GAINTA ITEM NO:RF-1004) COLOR:BLACK	M3.5X12 mm MATERIAL:STAINLESS SUS 304 COLOR:UNFINISHED	113.7X35.2X69 mm
ALUG704SR060	ALUMINIUM EXTRUSION 6063/ SILVER ANODIZED(PANTONE 877C)					
ALUG704RD060	ALUMINIUM EXTRUSION 6063/ RED ANODIZED(PANTONE 187C)					
ALUG704BU060	ALUMINIUM EXTRUSION 6063/ BLUE ANODIZED(PANTONE 306C)					
ALUG704BK060	ALUMINIUM EXTRUSION 6063/ BLACK ANODIZED(PANTONE BLACK U)					
ALUG704GD110	ALUMINIUM EXTRUSION 6063/ GOLDEN ANODIZED(PANTONE 4675C)	DIE-CAST ALUMINIUM ADC-12 /PAINTED BLACK(RAL9005)	Ø6X0.5 mm MATERIAL:PC COLOR:CLEAR	Ø12X5 mm MATERIAL:RUBBER (GAINTA ITEM NO:RF-1004) COLOR:BLACK	M3.5X12 mm MATERIAL:STAINLESS SUS 304 COLOR:UNFINISHED	113.7X35.2X119 mm
ALUG704SR110	ALUMINIUM EXTRUSION 6063/ SILVER ANODIZED(PANTONE 877C)					
ALUG704RD110	ALUMINIUM EXTRUSION 6063/ RED ANODIZED(PANTONE 187C)					
ALUG704BU110	ALUMINIUM EXTRUSION 6063/ BLUE ANODIZED(PANTONE 306C)					
ALUG704BK110	ALUMINIUM EXTRUSION 6063/ BLACK ANODIZED(PANTONE BLACK U)					
ALUG704GD160	ALUMINIUM EXTRUSION 6063/ GOLDEN ANODIZED(PANTONE 4675C)	DIE-CAST ALUMINIUM ADC-12 /PAINTED BLACK(RAL9005)	Ø6X0.5 mm MATERIAL:PC COLOR:CLEAR	Ø12X5 mm MATERIAL:RUBBER (GAINTA ITEM NO:RF-1004) COLOR:BLACK	M3.5X12 mm MATERIAL:STAINLESS SUS 304 COLOR:UNFINISHED	113.7X35.2X169 mm
ALUG704SR160	ALUMINIUM EXTRUSION 6063/ SILVER ANODIZED(PANTONE 877C)					
ALUG704RD160	ALUMINIUM EXTRUSION 6063/ RED ANODIZED(PANTONE 187C)					
ALUG704BU160	ALUMINIUM EXTRUSION 6063/ BLUE ANODIZED(PANTONE 306C)					
ALUG704BK160	ALUMINIUM EXTRUSION 6063/ BLACK ANODIZED(PANTONE BLACK U)					

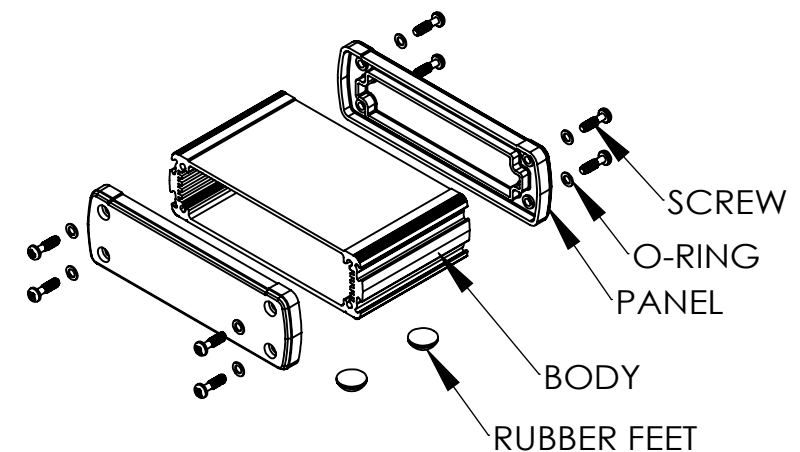
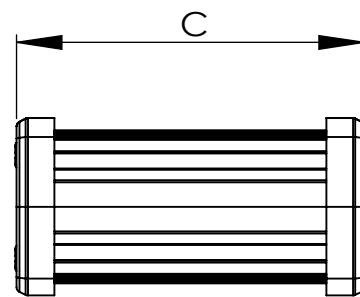
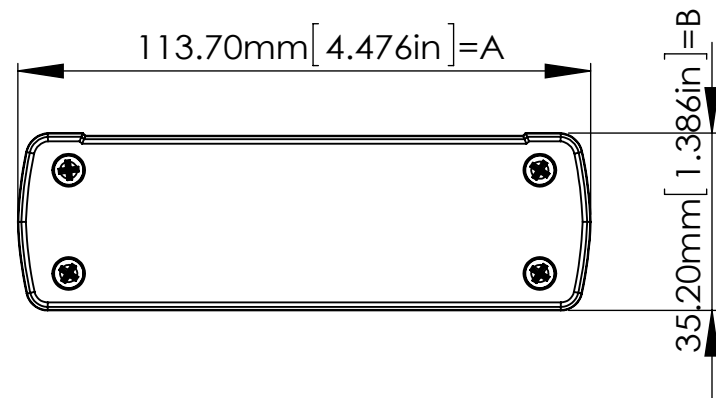

宣又實業有限公司  
GAINTA INDUSTRIES LTD.

繪圖 DRA'D BY  
JACKY

日期 DATE  
2015/09/01

材質 MATE.  
--

圖名TITLE:  
ALUG704XXXXX

圖號DWG NO:

版次REVISED:  
A

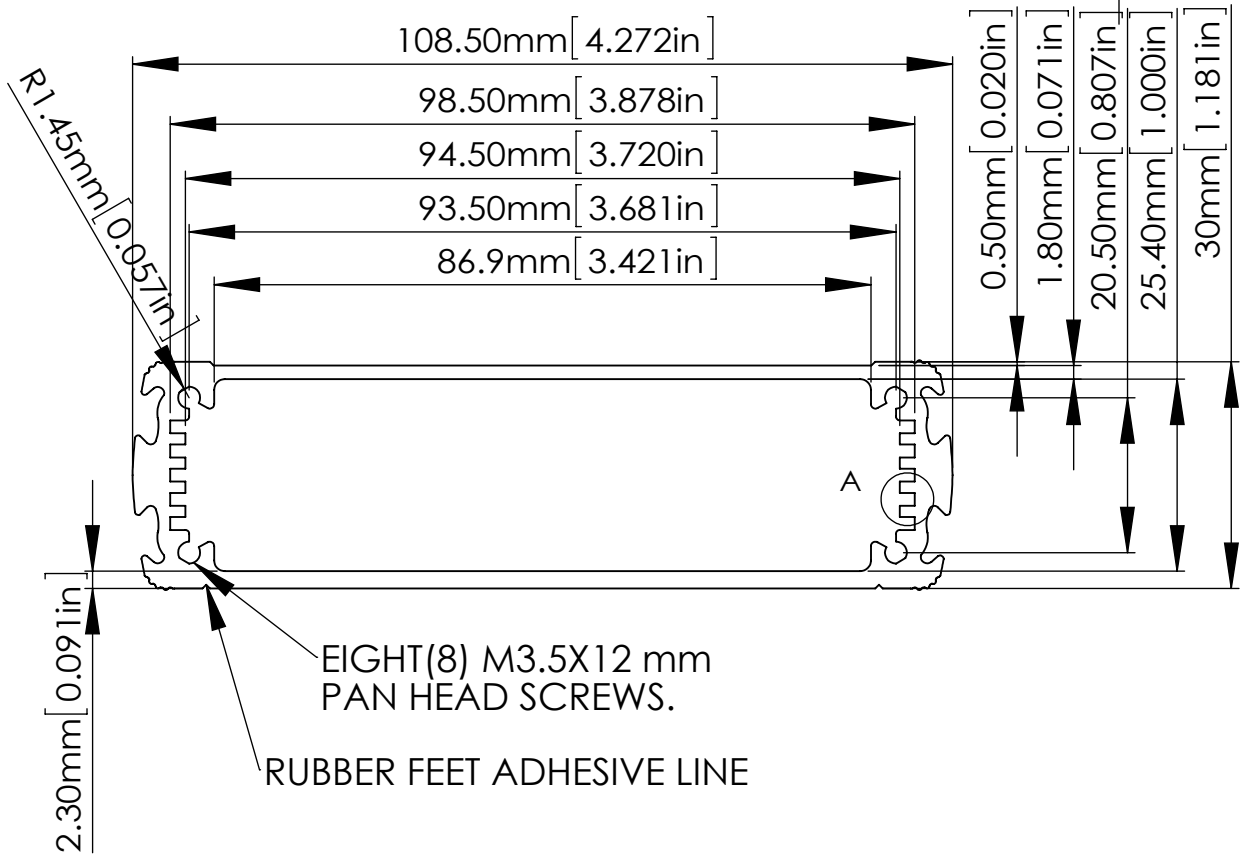
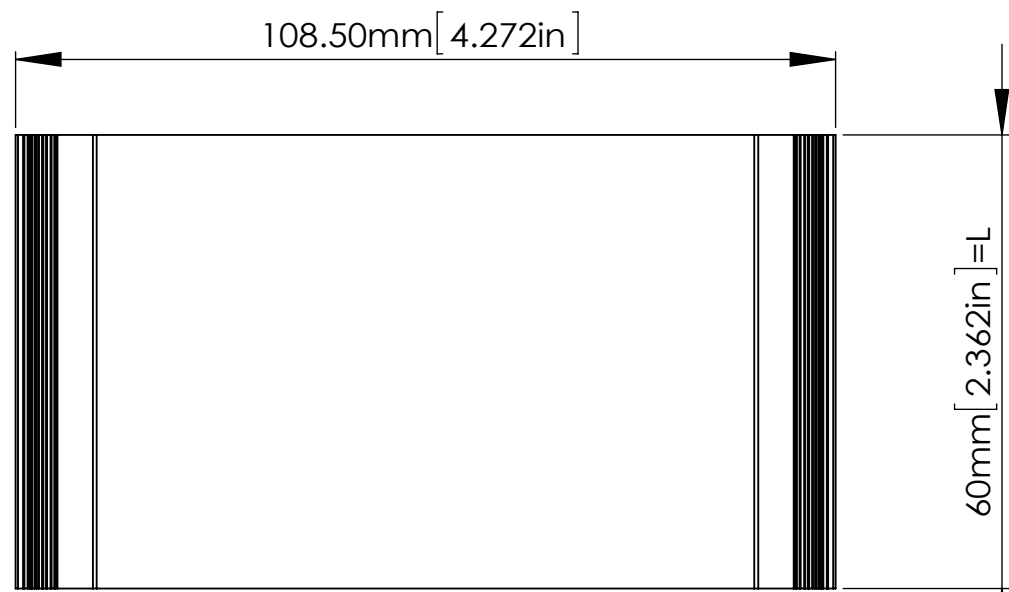

ITEM NO.	L(mm)
ALUG704XX060	60 mm
ALUG704XX110	110 mm
ALUG704XX160	160 mm

**BODY**

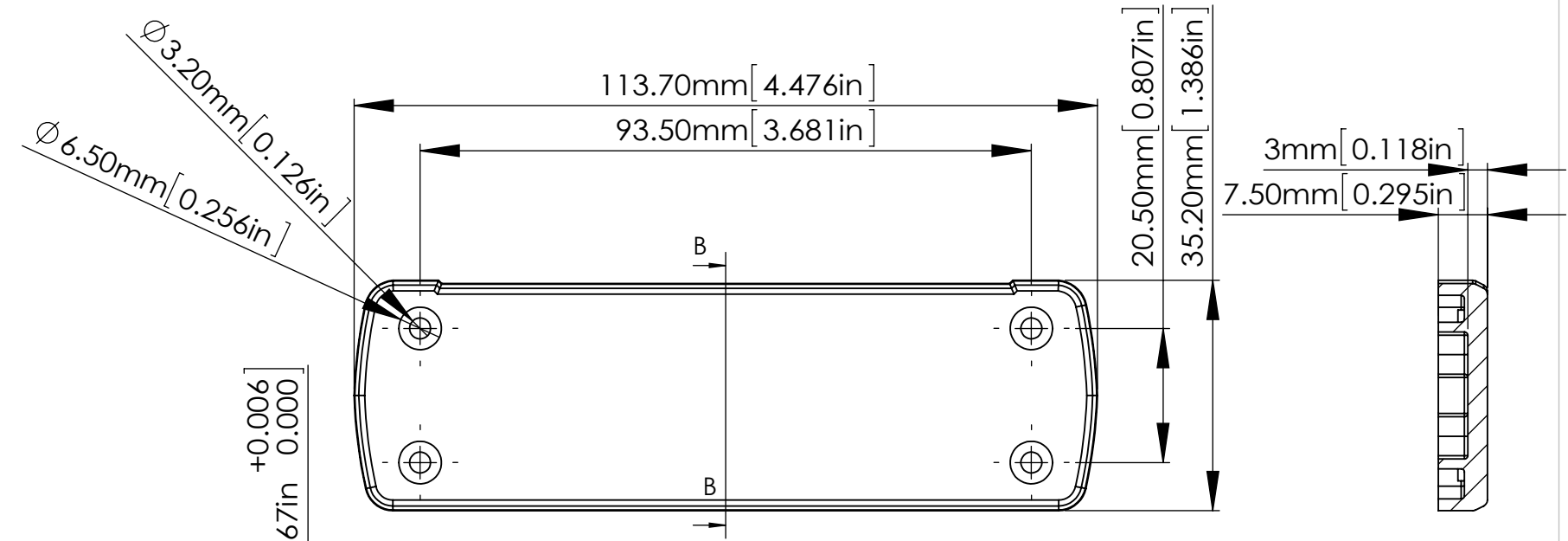

SECTION B-B

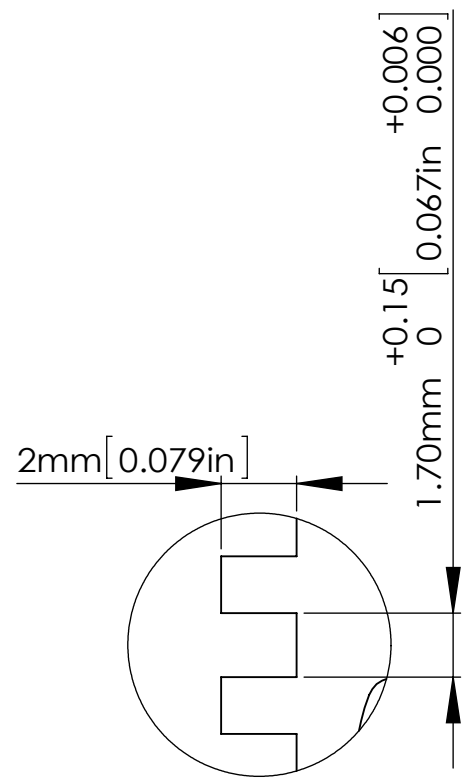

SECTION A  
SCALE 5:1

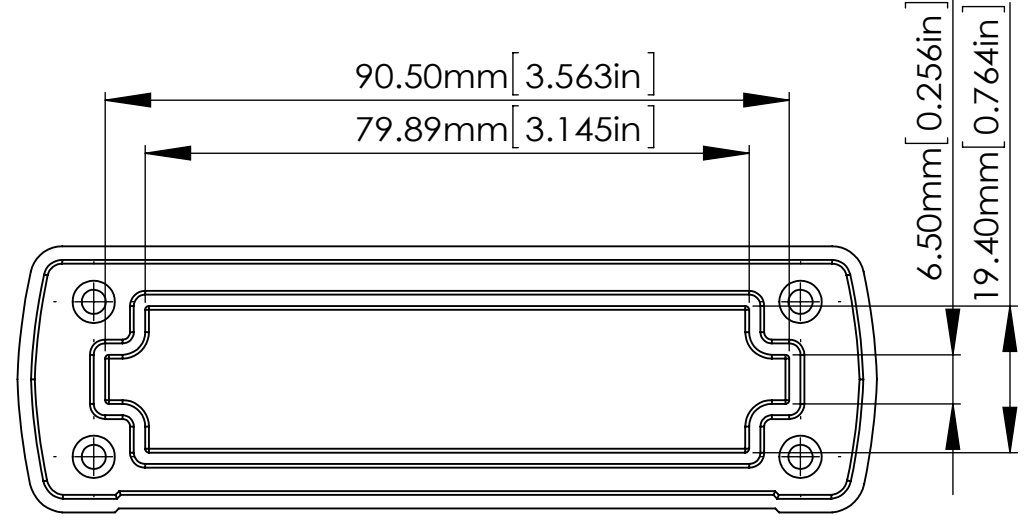

**PANEL**

According to ISO 2768-m	
Measuring DIM=L	Tolerances
0.5<L<=3.0mm	±0.1mm
3.0<L<=6.0 mm	±0.1mm
6.0<L<=30.0 mm	±0.2mm
30.0<L<=120.0 mm	±0.3mm
120.0<L<=400.0 mm	±0.5mm
400.0<L<=1000.0 mm	±0.8mm

宣又實業有限公司 GAINTA INDUSTRIES LTD.	繪圖	DRA'D BY	日期	DATE	材質	MATE.	圖名TITLE:	圖號DWG NO:	版次REVISED:
		JACKY	2015/06/08			--	ALUG704XXXXX		A