

ITEM NO	BODY	PANEL	O-RING	RUBBER FEET	SCREW	EXTERNAL DIMENSION(mm) AXBXC
ALUG702GD040	ALUMINIUM EXTRUSION 6063/ GOLDEN ANODIZED(PANTONE 4675C)	DIE-CAST ALUMINIUM ADC-12 /PAINTED BLACK(RAL9005)	Ø6X0.5 mm MATERIAL:PC COLOR:CLEAR	Ø12X5 mm MATERIAL:RUBBER (GAINTA ITEM NO:RF-1004) COLOR:BLACK	M3.5X12 mm MATERIAL:STAINLESS SUS 304 COLOR:UNFINISHED	68.7X35.2X49 mm
ALUG702SR040	ALUMINIUM EXTRUSION 6063/ SILVER ANODIZED(PANTONE 877C)					
ALUG702RD040	ALUMINIUM EXTRUSION 6063/ RED ANODIZED(PANTONE 187C)					
ALUG702BU040	ALUMINIUM EXTRUSION 6063/ BLUE ANODIZED(PANTONE 306C)					
ALUG702BK040	ALUMINIUM EXTRUSION 6063/ BLACK ANODIZED(PANTONE BLACK U)					
ALUG702GD080	ALUMINIUM EXTRUSION 6063/ GOLDEN ANODIZED(PANTONE 4675C)	DIE-CAST ALUMINIUM ADC-12 /PAINTED BLACK(RAL9005)	Ø6X0.5 mm MATERIAL:PC COLOR:CLEAR	Ø12X5 mm MATERIAL:RUBBER (GAINTA ITEM NO:RF-1004) COLOR:BLACK	M3.5X12 mm MATERIAL:STAINLESS SUS 304 COLOR:UNFINISHED	68.7X35.2X89 mm
ALUG702SR080	ALUMINIUM EXTRUSION 6063/ SILVER ANODIZED(PANTONE 877C)					
ALUG702RD080	ALUMINIUM EXTRUSION 6063/ RED ANODIZED(PANTONE 187C)					
ALUG702BU080	ALUMINIUM EXTRUSION 6063/ BLUE ANODIZED(PANTONE 306C)					
ALUG702BK080	ALUMINIUM EXTRUSION 6063/ BLACK ANODIZED(PANTONE BLACK U)					
ALUG702GD120	ALUMINIUM EXTRUSION 6063/ GOLDEN ANODIZED(PANTONE 4675C)	DIE-CAST ALUMINIUM ADC-12 /PAINTED BLACK(RAL9005)	Ø6X0.5 mm MATERIAL:PC COLOR:CLEAR	Ø12X5 mm MATERIAL:RUBBER (GAINTA ITEM NO:RF-1004) COLOR:BLACK	M3.5X12 mm MATERIAL:STAINLESS SUS 304 COLOR:UNFINISHED	68.7X35.2X129 mm
ALUG702SR120	ALUMINIUM EXTRUSION 6063/ SILVER ANODIZED(PANTONE 877C)					
ALUG702RD120	ALUMINIUM EXTRUSION 6063/ RED ANODIZED(PANTONE 187C)					
ALUG702BU120	ALUMINIUM EXTRUSION 6063/ BLUE ANODIZED(PANTONE 306C)					
ALUG702BK120	ALUMINIUM EXTRUSION 6063/ BLACK ANODIZED(PANTONE BLACK U)					

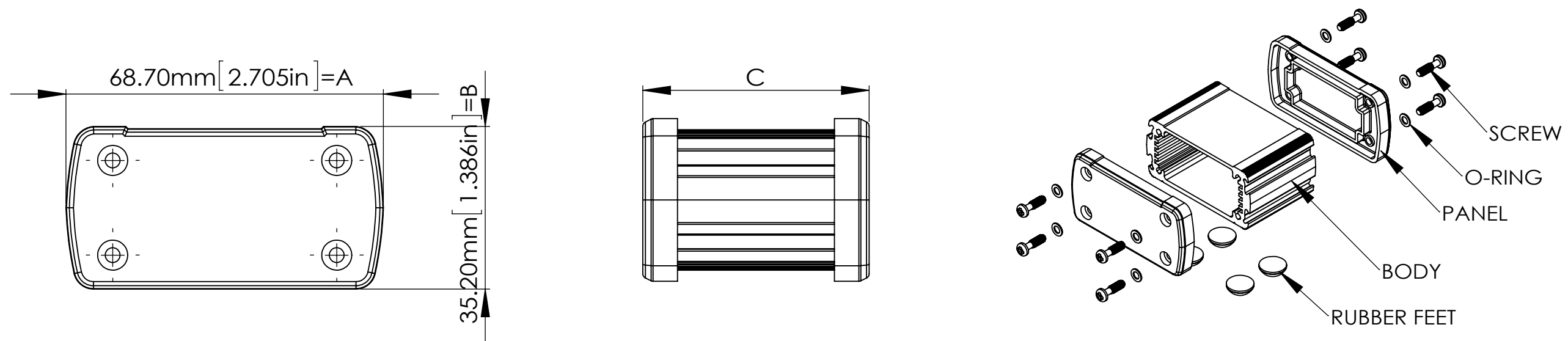

宣又實業有限公司
GAINTA INDUSTRIES LTD.

繪圖 DRA'D BY
JACKY

日期 DATE
2015/09/01

材質 MATE.
--

圖名TITLE:
ALUG702XXXXX

圖號DWG NO:

版次REVISED:
A

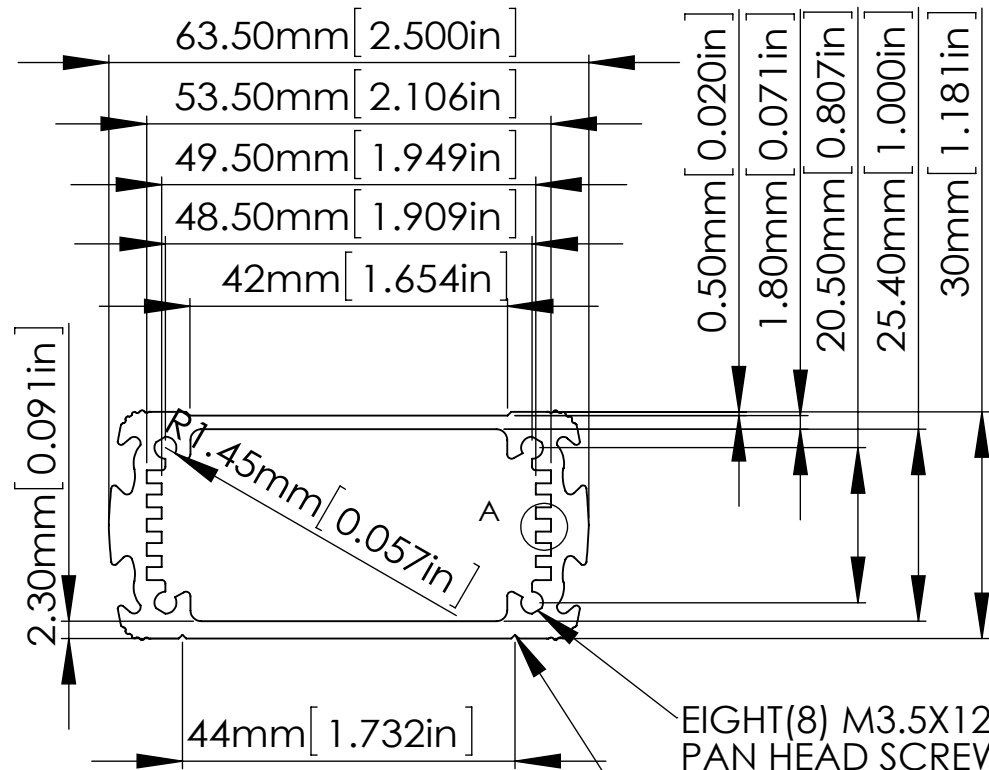
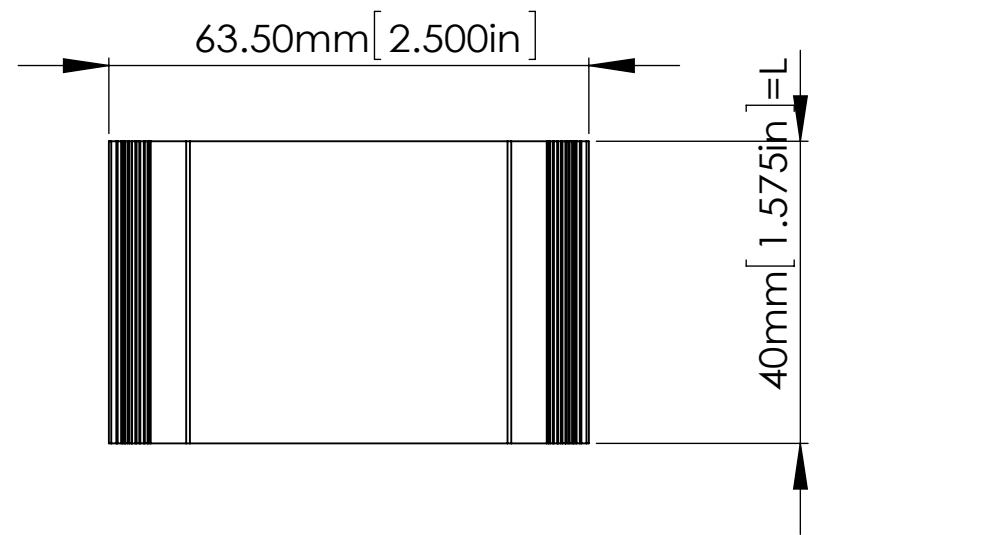

EIGHT(8) M3.5X12 mm
PAN HEAD SCREWS.
RUBBER FEET ADHESIVE LINE

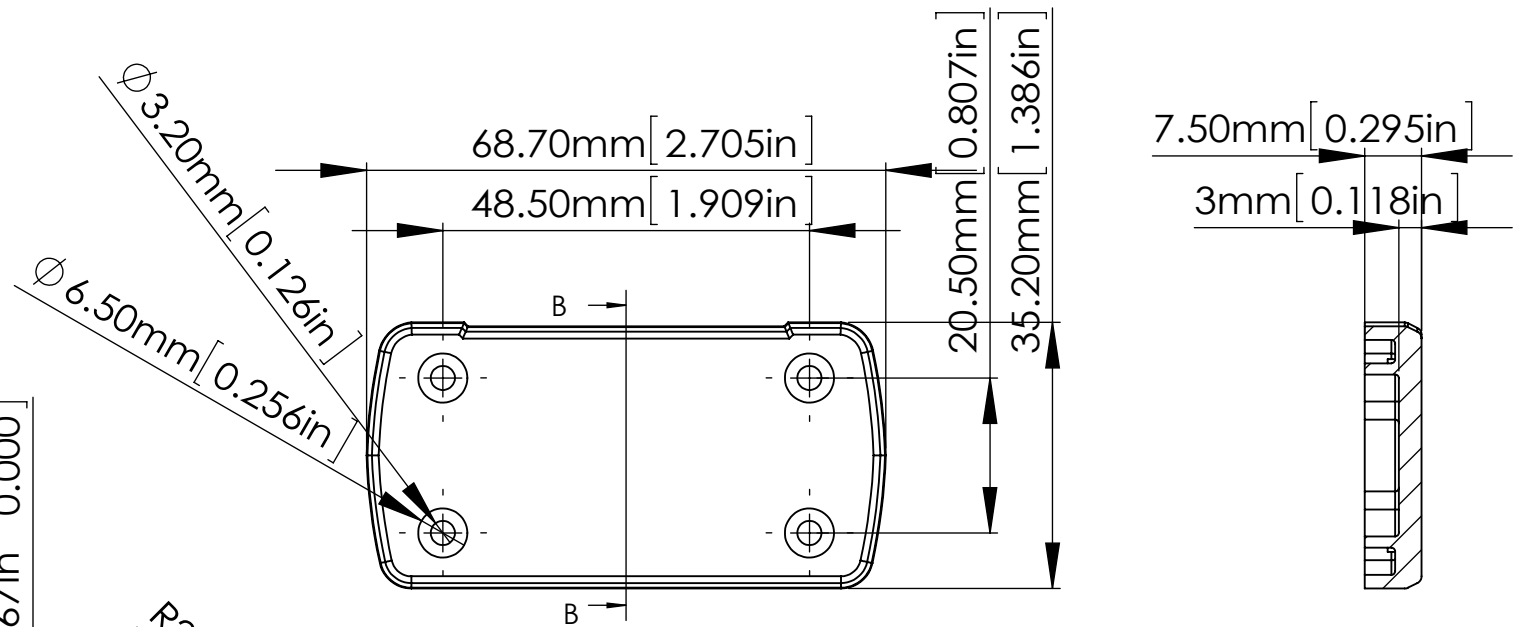
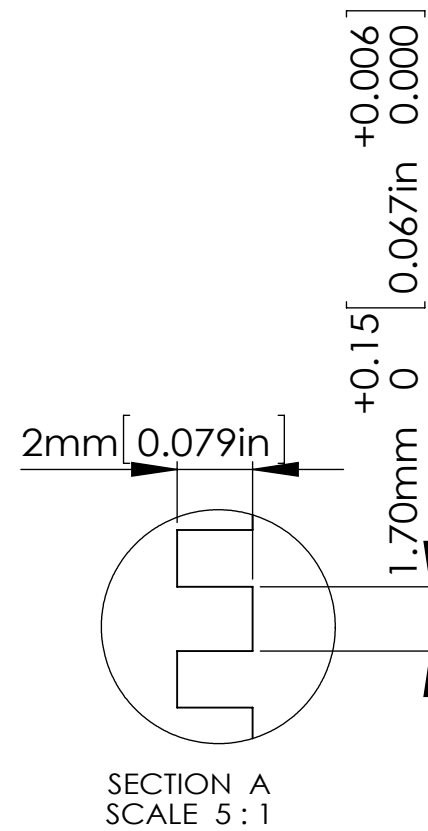

SECTION B-B
SCALE 1:1

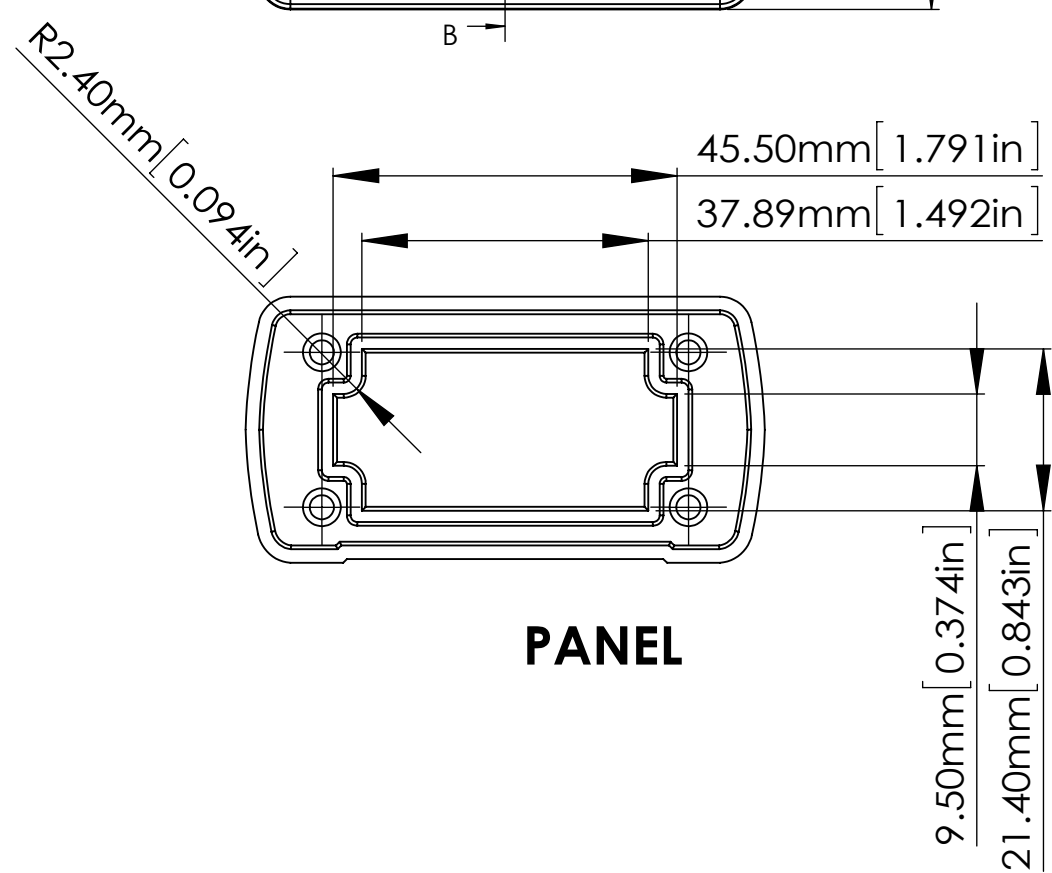

PANEL

ITEM NO.	L(mm)
ALUG702XX040	40 mm
ALUG702XX080	80 mm
ALUG702XX120	120 mm

BODY

According to ISO 2768-m	
Measuring DIM=L	Tolerances
0.5<L<=3.0mm	±0.1mm
3.0<L<=6.0 mm	±0.1mm
6.0<L<=30.0 mm	±0.2mm
30.0<L<=120.0 mm	±0.3mm
120.0<L<=400.0 mm	±0.5mm
400.0<L<=1000.0 mm	±0.8mm

宣又實業有限公司
GAINTA INDUSTRIES LTD.

繪圖 DRA'D BY
JACKY

日期 DATE
2015/06/01

材質 MATE.
--

圖名TITLE:
ALUG702XXXXX

圖號DWG NO:

版次REVISED:
A