

ITEM NO	BODY	PANEL	O-RING	RUBBER FEET	SCREW	EXTERNAL DIMENSION(mm) AXBXC
ALUG705GD060	ALUMINIUM EXTRUSION 6063/ GOLDEN ANODIZED(PANTONE 4675C)	DIE-CAST ALUMINIUM ADC-12 /PAINTED BLACK(RAL9005)	Ø6X0.5 mm MATERIAL:PC COLOR:CLEAR	Ø12X5 mm MATERIAL:RUBBER (GAINTA ITEM NO:RF-1004) COLOR:BLACK	M3.5X12 mm MATERIAL:STAINLESS SUS 304 COLOR:UNFINISHED	115.1X51.6X69 mm
ALUG705SR060	ALUMINIUM EXTRUSION 6063/ SILVER ANODIZED(PANTONE 877C)					
ALUG705RD060	ALUMINIUM EXTRUSION 6063/ RED ANODIZED(PANTONE 187C)					
ALUG705BU060	ALUMINIUM EXTRUSION 6063/ BLUE ANODIZED(PANTONE 306C)					
ALUG705BK060	ALUMINIUM EXTRUSION 6063/ BLACK ANODIZED(PANTONE BLACK U)					
ALUG705GD110	ALUMINIUM EXTRUSION 6063/ GOLDEN ANODIZED(PANTONE 4675C)	DIE-CAST ALUMINIUM ADC-12 /PAINTED BLACK(RAL9005)	Ø6X0.5 mm MATERIAL:PC COLOR:CLEAR	Ø12X5 mm MATERIAL:RUBBER (GAINTA ITEM NO:RF-1004) COLOR:BLACK	M3.5X12 mm MATERIAL:STAINLESS SUS 304 COLOR:UNFINISHED	115.1X51.6X119 mm
ALUG705SR110	ALUMINIUM EXTRUSION 6063/ SILVER ANODIZED(PANTONE 877C)					
ALUG705RD110	ALUMINIUM EXTRUSION 6063/ RED ANODIZED(PANTONE 187C)					
ALUG705BU110	ALUMINIUM EXTRUSION 6063/ BLUE ANODIZED(PANTONE 306C)					
ALUG705BK110	ALUMINIUM EXTRUSION 6063/ BLACK ANODIZED(PANTONE BLACK U)					
ALUG705GD160	ALUMINIUM EXTRUSION 6063/ GOLDEN ANODIZED(PANTONE 4675C)	DIE-CAST ALUMINIUM ADC-12 /PAINTED BLACK(RAL9005)	Ø6X0.5 mm MATERIAL:PC COLOR:CLEAR	Ø12X5 mm MATERIAL:RUBBER (GAINTA ITEM NO:RF-1004) COLOR:BLACK	M3.5X12 mm MATERIAL:STAINLESS SUS 304 COLOR:UNFINISHED	115.1X51.6X169 mm
ALUG705SR160	ALUMINIUM EXTRUSION 6063/ SILVER ANODIZED(PANTONE 877C)					
ALUG705RD160	ALUMINIUM EXTRUSION 6063/ RED ANODIZED(PANTONE 187C)					
ALUG705BU160	ALUMINIUM EXTRUSION 6063/ BLUE ANODIZED(PANTONE 306C)					
ALUG705BK160	ALUMINIUM EXTRUSION 6063/ BLACK ANODIZED(PANTONE BLACK U)					

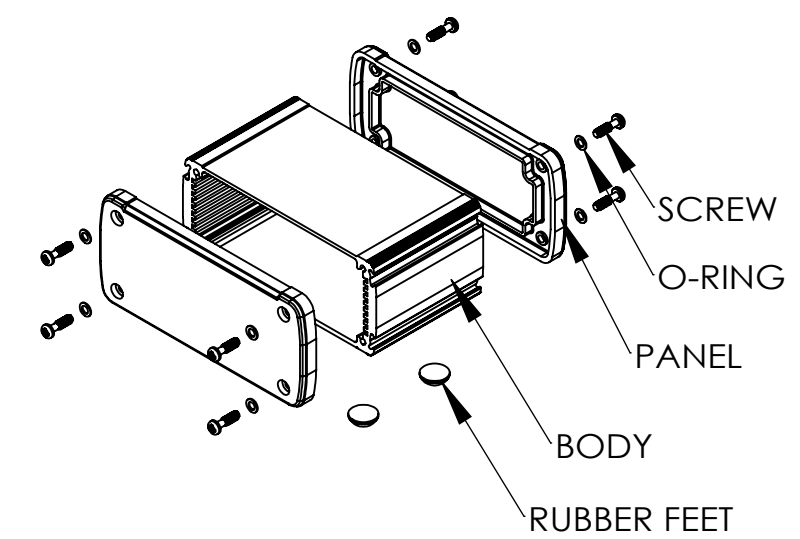

宣又實業有限公司 GAINTA INDUSTRIES LTD.	繪圖	DRA'D BY	日期	DATE	材質	MATE.	圖名TITLE:	圖號DWG NO:	版次REVISED:
		JACKY	2015/09/01		--	ALUG705XXXXX		A	

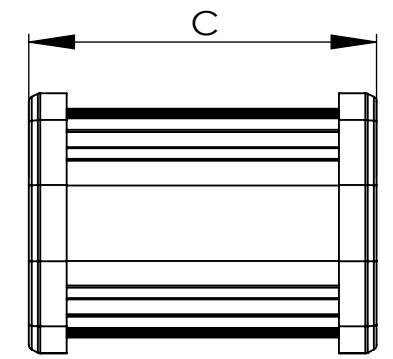
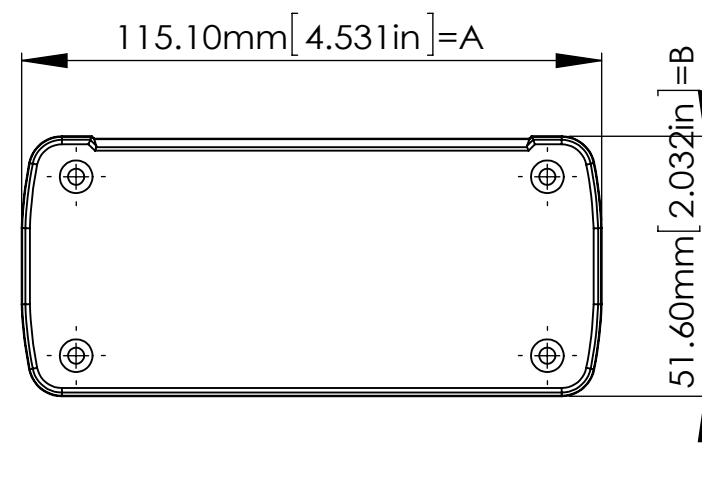
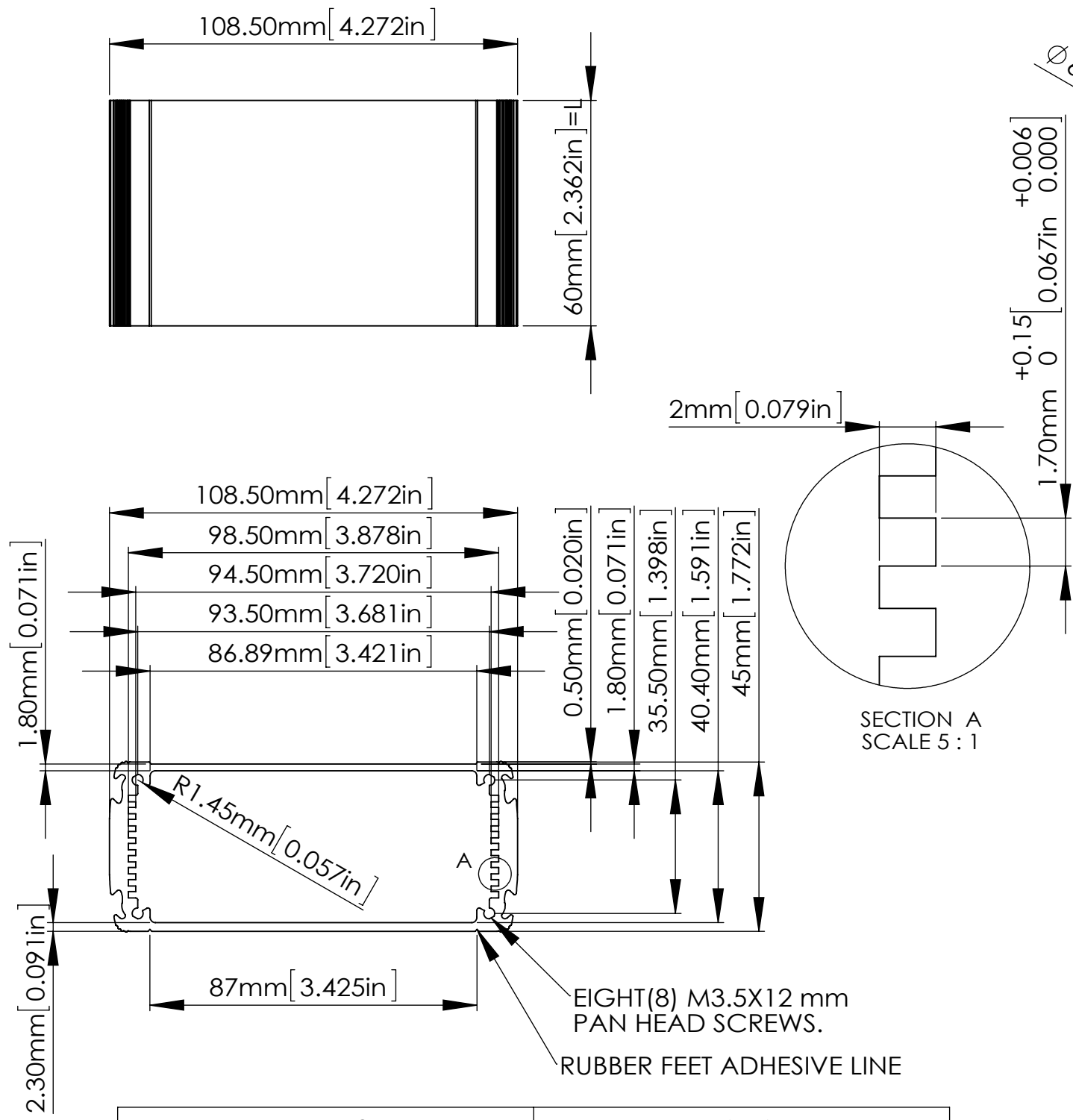

SECTION A
SCALE 5 : 1

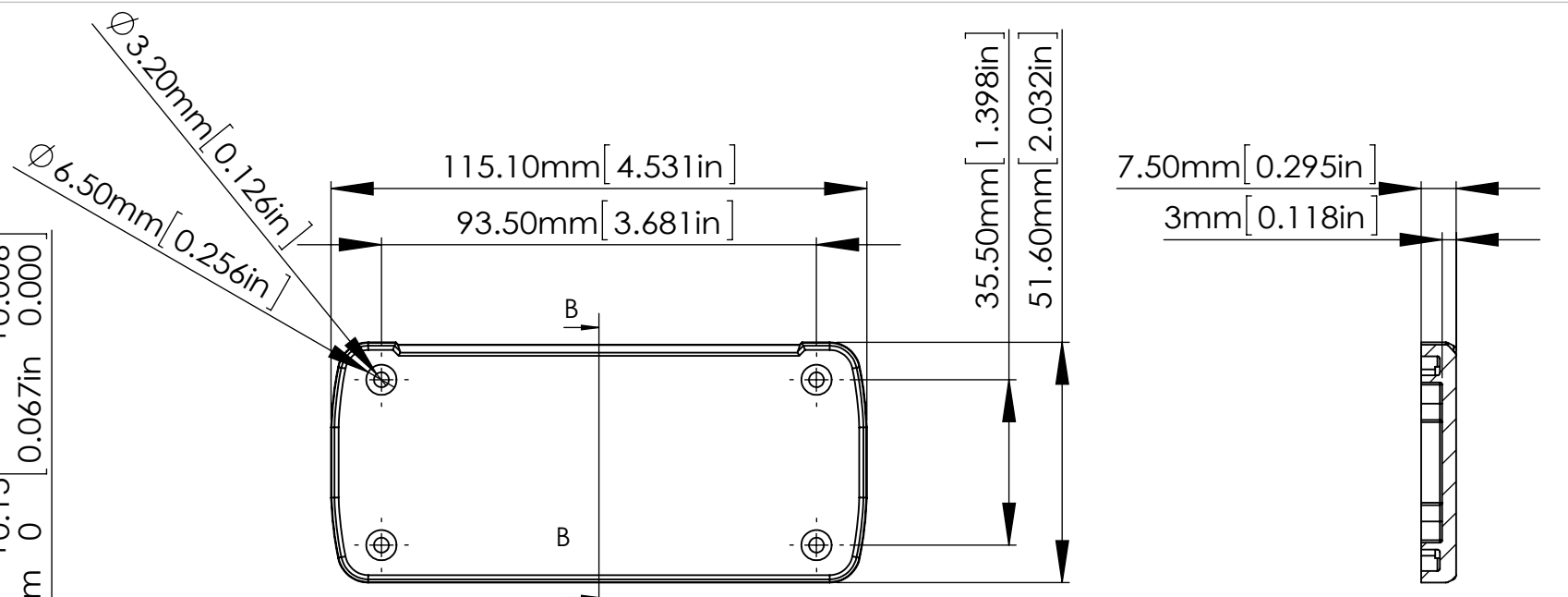

SECTION B-B
SCALE 2 : 3

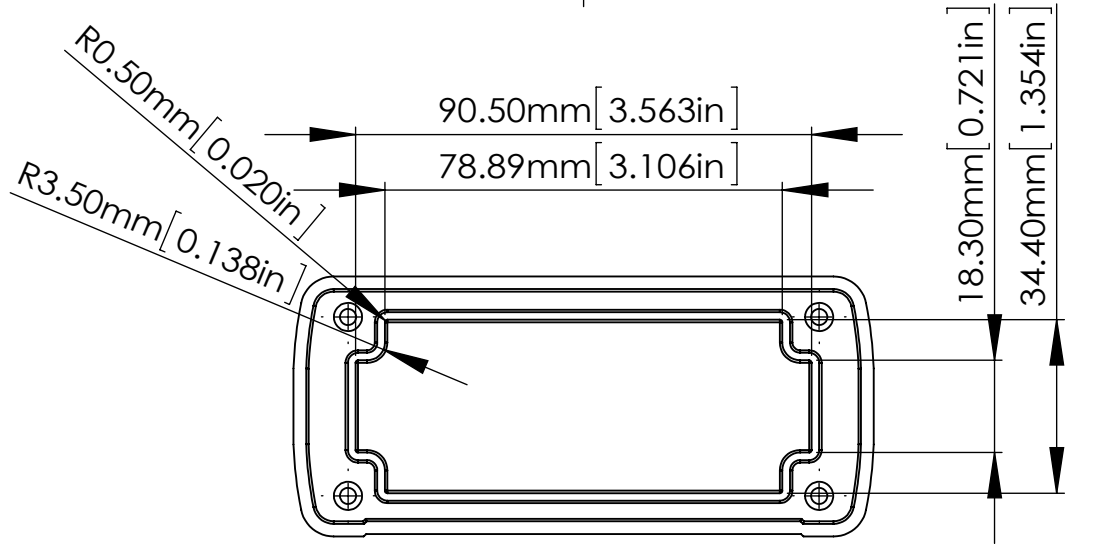

PANEL

ITEM NO.	L(mm)
ALUG705XX060	60 mm
ALUG705XX110	110 mm
ALUG705XX160	160 mm

BODY

According to ISO 2768-m	
Measuring DIM=L	Tolerances
0.5<L<=3.0mm	±0.1mm
3.0<L<=6.0 mm	±0.1mm
6.0<L<=30.0 mm	±0.2mm
30.0<L<=120.0 mm	±0.3mm
120.0<L<=400.0 mm	±0.5mm
400.0<L<=1000.0 mm	±0.8mm

宣又實業有限公司 GAINTA INDUSTRIES LTD.	繪圖	DRA'D BY	日期	DATE	材質	MATE.	圖名TITLE:	圖號DWG NO:	版次REVISED:
		JACKY	2015/06/08		--	ALUG705XXXXX		A	