

LED Driver PR4401 / PR4402

0.9 V Boost Driver for White LEDs Requires Only One External Component

The PR4401 and PR4402* are single cell step-up converters for white LEDs operating from a supply voltage of less than 0.9 V. Only one external inductor is needed for operation of a white LED. PR4401 is recommended for mean LED currents of up to 20 mA, PR4402 for up to 40 mA. This makes PR4401 and PR4402 ideal for use in low-cost or small-sized applications such as LED flashlights or LCD backlighting for portable devices.

FEATURES

- minimum startup voltage 0.9 V
- 200 / 250 mA peak output current
- only one external component required
- battery deep discharge protection

APPLICATIONS

- Small-sized LED torches
- LCD backlighting
- LED indicator lights

TYPICAL APPLICATION

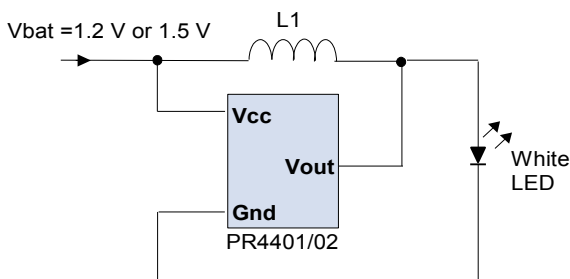

For output currents higher than 20 mA an additional blocking capacitor at Vcc is recommended.

The inductance L1 determines the LED current:

Inductance L1	Mean current	For
47 μ H	6.5 mA	PR4401
32 μ H	8.3 mA	PR4401
26.7 μ H	10.8 mA	PR4401
22 μ H	11 mA	PR4401
14.7 μ H	14 mA	PR4401
10 μ H	22 mA	PR4401/4402
6.8 μ H *	32 mA *	PR4402
4.7 μ H *	40 mA *	PR4402

PIN DESCRIPTION

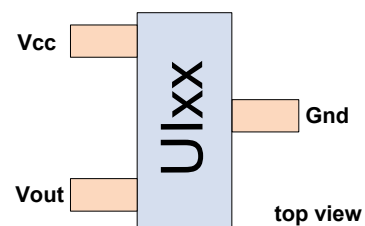

Topside marking: "UI" (PR4401) or "UJ" (PR4402) with a two-digit lot code Package SOT23-3 or COB on request

PIN Description:

PIN Name	PIN Function Description
Vcc	Supply voltage
Vout	Output voltage, LED connection
Gnd	Ground connection

* PR4402 only measured with inductor Murata type LQH32C series
10 - 22 μ H: one white LED
4.7 - 6.8 μ H: two white LEDs in parallel

LED Driver PR4401 / PR4402

Electrical Properties

BLOCK DIAGRAM

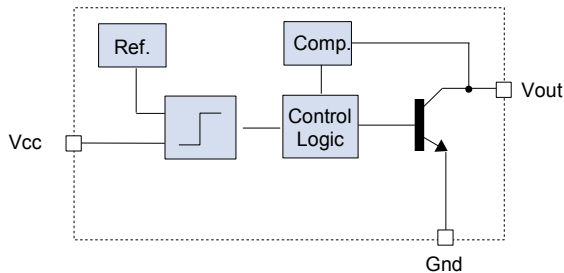

ABSOLUTE MAXIMUM RATINGS

(PR4401 and PR4402)

Parameter	Units	Min	Max
Vcc (no damage)	[V]	-0.3	8
Operating Temperature Range	[°C]	-20	85
Storage Temperature Range	[°C]	-55	150
Electrostatic Discharge (ESD) Protection	[kV]	2	-

ELECTRICAL CHARACTERISTICS

Vcc = 1.5 V, Ta = 25°C, 10 - 22 µH: one white LED / 4.7 - 6.8 µH: two white LEDs in parallel, unless otherwise noted.

Parameter	Conditions	Units	PR4401			PR4402		
			Min	Typ	Max	Min	Typ	Max
Supply Voltage,	min. operating	L1 = 10...22 µH		0.70	0.80		0.70	0.80
	min. startup	Ta = 25°C		0.90	0.95		0.90	0.95
	max. operating		1.90			1.90		
Supply Voltage,	min. operating	L1 = 10...22 µH		0.80	0.90		0.80	0.90
	min. startup	Ta = 0...60°C		1.00	1.05		1.00	1.05
	max. operating		1.90			1.90		
LED Mean Current measured with L1 type LQH32C Murata	L1 = 47 µH	[mA]		6.5			--	
	L1 = 32 µH	[mA]		8.3			--	
	L1 = 26.7 µH	[mA]		10.8			--	
	L1 = 22 µH	[mA]		12			12	
	L1 = 14.7 µH	[mA]		15			15	
	L1 = 10 µH	[mA]		23			23	
	L1 = 6.8 µH	[mA]		--			32	
L1 = 4.7 µH	[mA]		--			40		
Switching Current at Vout	Vout = 0.4 V	[mA]	200			250		
Switching Frequency		[kHz]		500			500	
Quiescent supply current	Vcc > 950 mV	[mA]		4	5		8	10
	Vcc = 600 mV	[µA]		50			100	
	Vcc = 400 mV	[µA]		10			20	
Efficiency		[%]		80			80	
Vout		[V]	Vcc		15			15

LED Driver PR4401 / PR4402

Typical Characteristics

TEST CIRCUIT

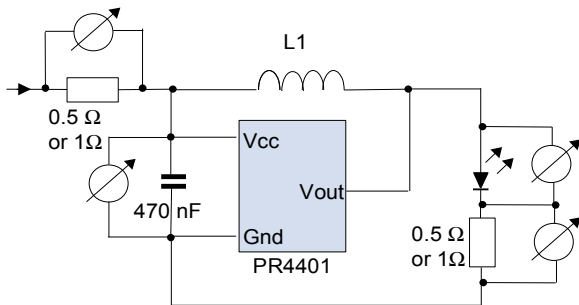

MEASUREMENT + CALCULATION OF EFFICIENCY

$$\text{Efficiency} [\%] = \frac{\frac{1}{T} \int_0^T (V_{LED} \cdot I_{LED}) dt}{\frac{1}{T} \int_0^T (V_{in} \cdot I_{in}) dt} \cdot 100$$

Depending on test setup and measuring method, efficiency values can vary by approx. $\pm 5\%$, and peak current values can vary by up to $\pm 20\%$, Accuracy of mean currents: ± 1 mA. Measuring conditions for all diagrams, unless otherwise noted:

- $T_a = 25^\circ\text{C}$
- one LED connected (peak voltage 4.2...5.8 V)

A LQH32C from Murata has been used as reference inductor, the DC resistance is specified as

- $0.44 \Omega \pm 30\%$ for $10 \mu\text{H}$ (max current 300 mA)
- $0.71 \Omega \pm 30\%$ for $22 \mu\text{H}$ (max. current 250 mA)
- $1.30 \Omega \pm 30\%$ for a $47 \mu\text{H}$ inductor (max. current 170 mA).

OSCILLOSCOPE DISPLAYS

PR4401; LED voltage (CH1) and LED current (CH2, over 0.5Ω resistor)

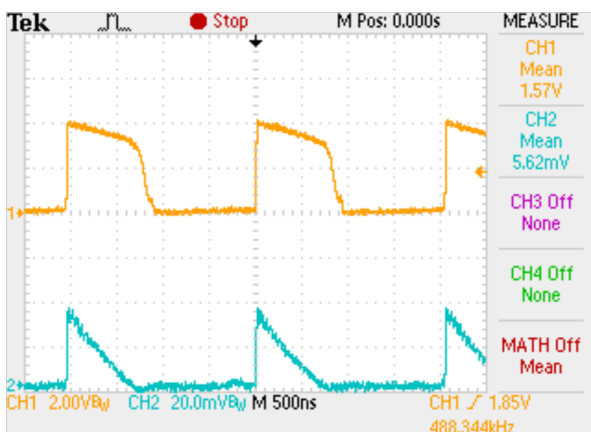

with $L1 = 22 \mu\text{H}$



with $L1 = 10 \mu\text{H}$

LED Driver PR4401 / PR4402

Characteristic Performance Curves for PR4401

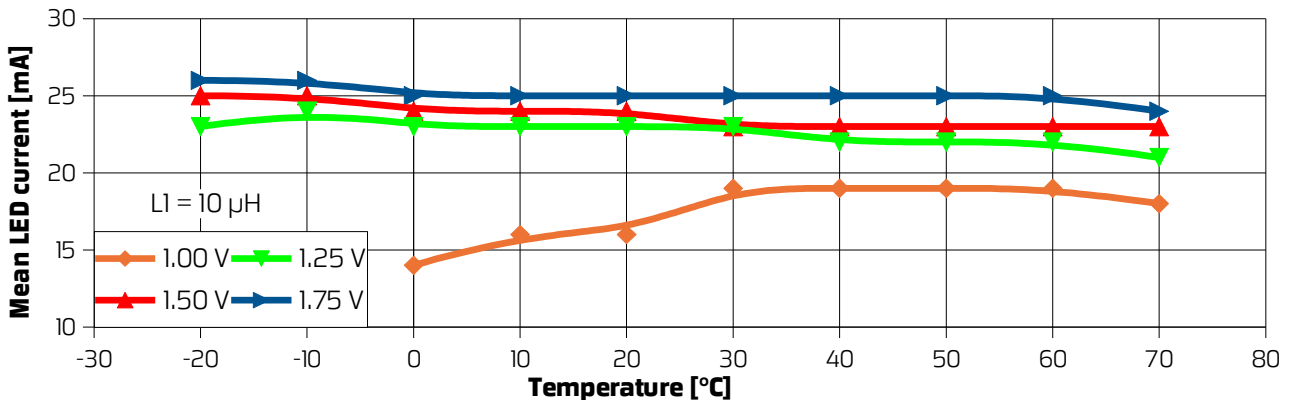
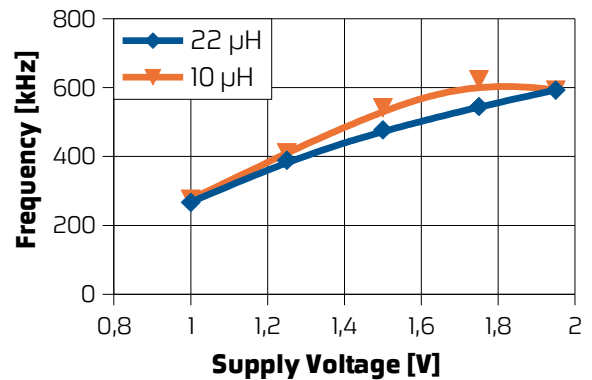
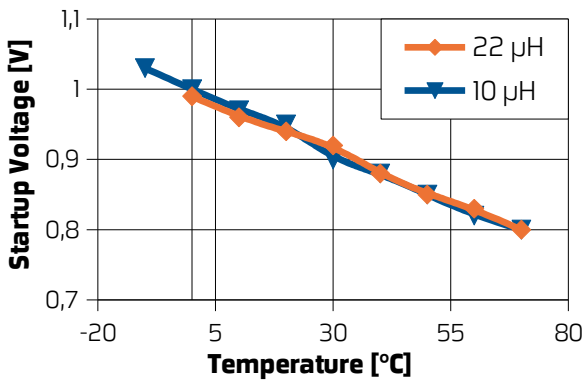
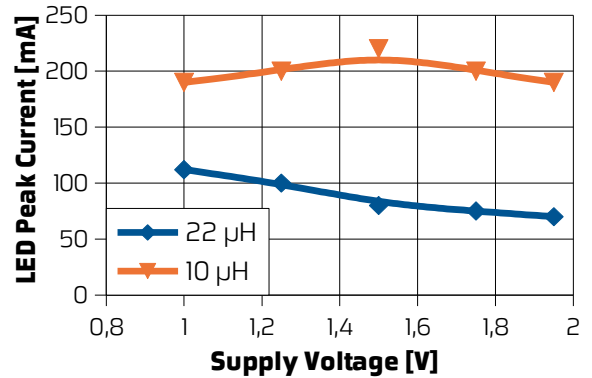
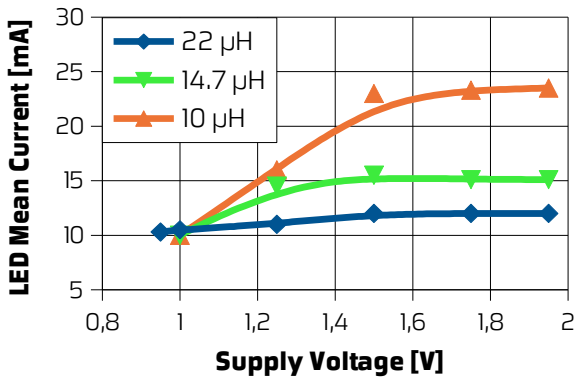
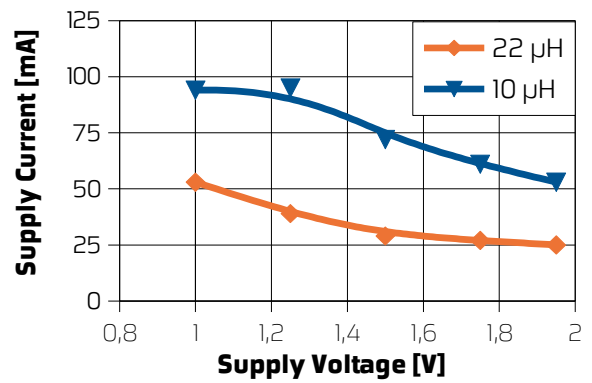
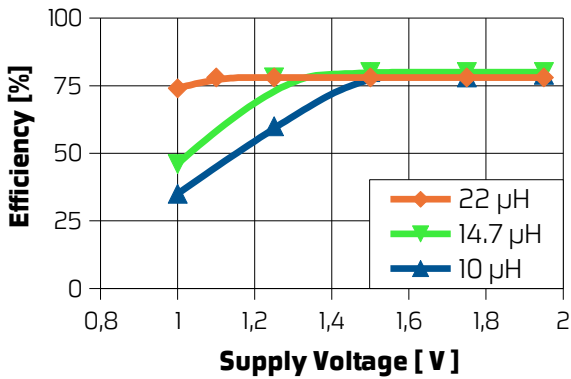

LED Driver PR4401 / PR4402

Characteristic Performance Curves for PR4402

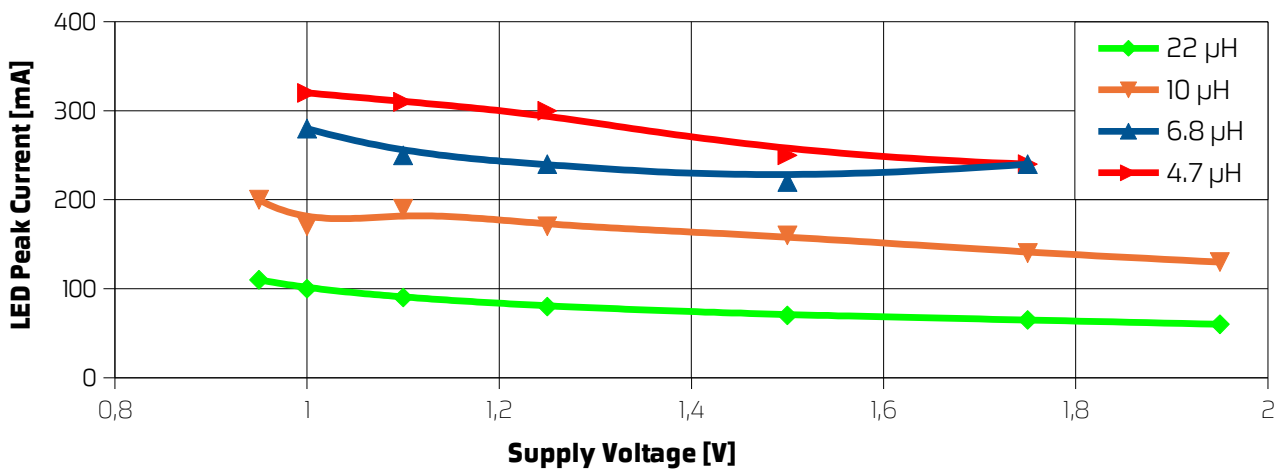
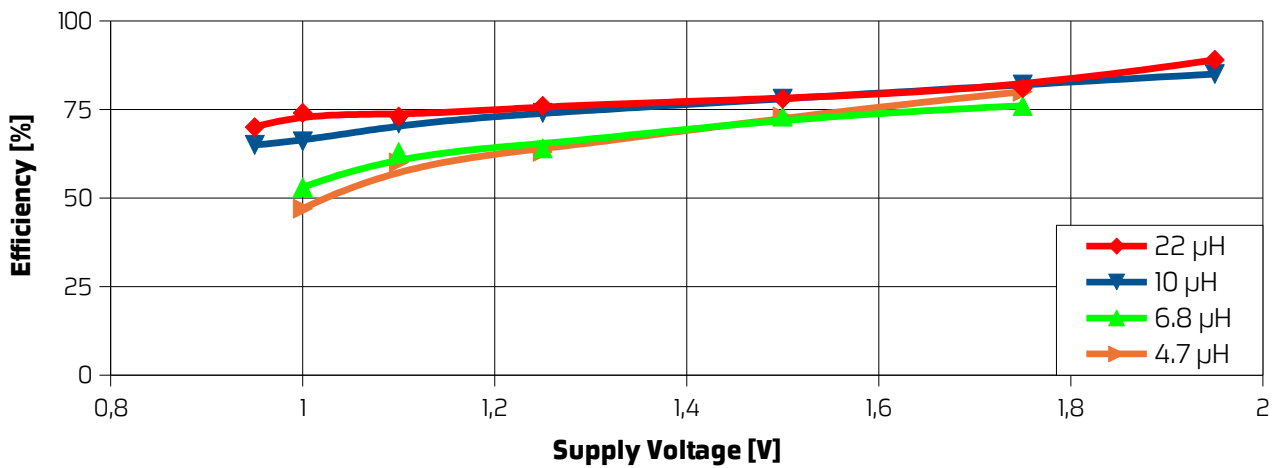
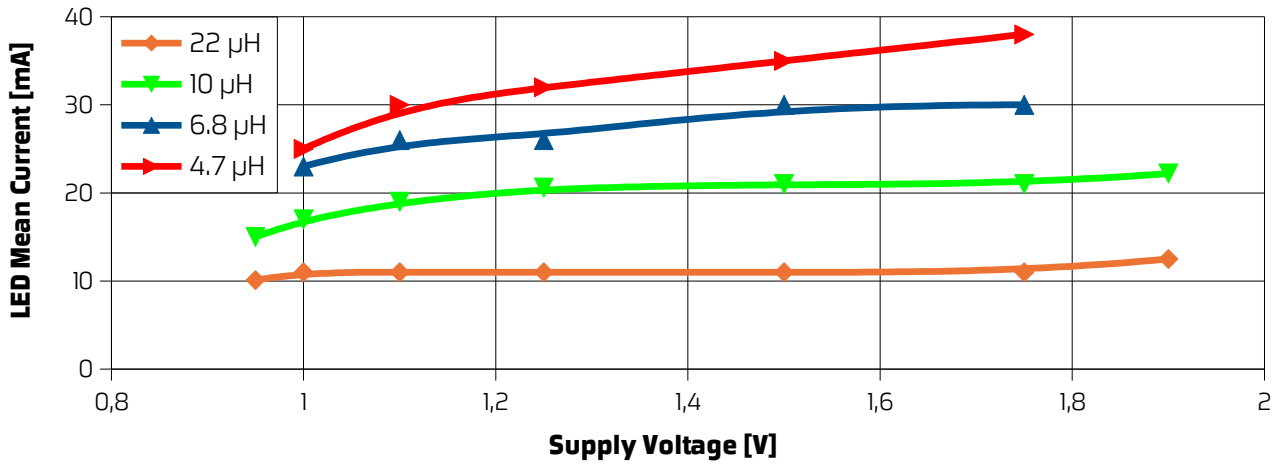

LED Driver PR4401 / PR4402

Application Notes

INFLUENCE OF THE LED FORWARD VOLTAGE

(measured with 1 LED / 2 LEDs in parallel; Vcc = 1.5 V)

Circuit	LED Peak Forward Voltage	LED Mean Current	Mean Supply Current	Efficiency
10 μ H 1 LED	5.8 V	20 mA	70 mA	77 %
10 μ H 2 LEDs	4.6 V	24 mA	70 mA	80 %
22 μ H 1 LED	4.2 V	13 mA	33 mA	82 %
22 μ H 2 LEDs	3.5 V	14 mA	32 mA	82 %

SELECTION OF PR4401 AND PR4402

The circuit type should be selected according to the required LED current:

- PR4401 is best operated with inductors between 10 and 22 μ H.
- PR4402 is best operated with inductors between 4.7 and 10 μ H.

Using lower inductances may lead to erratic behaviour, especially at low supply voltages and should be avoided.

Operating with higher inductances is possible and will lead to lower supply and LED currents. However the quiescent current which is independent of the inductance will lead to a lower overall efficiency. Since PR4402 has about twice the quiescent current of PR4401, it is not recommended for small LED currents.

LED COMPATIBILITY

It must be considered that the peak current through the LED is a factor of up to 7 higher than the mean current. LED lifetime may be affected if operated outside the range specified by the LED vendor. Since the emission spectrum of white LEDs usually depends on the current, the light color may shift to blueish white. High peak currents may also saturate the LED and reduce the light efficiency of the LED. If the rated LED peak current is exceeded, it is recommended to use a smoothing capacitor and diode to provide a continuous output current (see below). With most standard LEDs, this will improve the overall performance with inductors of 10 μ H and less, or mean output currents of 23 mA and more.

Note that with especially with the higher currents of PR4402 the current rating of most standard LEDs is exceeded, and more powerful or multiple LEDs must be used.

INDUCTOR COMPATIBILITY

While the series resistance of the coil has a small impact on the LED current, it is important that the saturation current is higher than the maximum peak current over the supply voltage range. Inductors optimized for DC-DC converters are mostly suitable.

CONNECTION FROM BATTERY

Due to high peak currents, it is important to connect the PR4401/PR4402 to the battery with short, low resistance wires, to achieve the best performance. A voltage drop along the wire affects LED current, efficiency and minimum startup and operating voltage. This is most critical for applications with low inductivity and high current. In cases where a longer wire from the battery cannot be avoided, a capacitor should be placed close to the Vcc and Gnd pin of PR4401. Typically capacitors between 220 nF and 1 μ F are used. With PR4402 operated at higher currents, a blocking capacitor is usually necessary even if wires or board layout are optimized.

LED Driver PR4401 / PR4402

Application Notes

TYPICAL BATTERY LIFE TIME

Battery	Lifetime L1 = 22 μ H LED mean current 12 mA	Battery L1 = 10 μ H LED mean current 23 mA
AA (Mignon, LR 6/AM-3)	55 h	27 h
AAA (Micro, LR 03/AM-4)	22 h	8 h

Conditions: one white LED connected, measured with single 1.5 V TDK Alkaline battery. Battery lifetime depends on battery capacity and operating conditions. Therefore the times indicated here can only give a rough indication of achievable times.

USING DIFFERENT BATTERY TYPES

The input voltage must be 1.9 V at maximum. At higher voltages the circuit may not trigger and start up correctly. Therefore operation with one Alkaline, NiCd, or NiMH cell (AA or AAA type) is recommended.

Alkaline button cells can also be used for supply. However, since high peak currents are drawn from the battery, button cells are recommended only with inductors of 22 μ H or more, depending on the battery type. A capacitor at the supply pins of PR4401 may also improve performance with button cells.

Lithium batteries are not suitable due to their higher voltage.

CONNECTING SEVERAL LEDs IN PARALLEL

When several LEDs are connected in parallel, it is necessary to match the forward voltage of these LEDs, to achieve a uniform brightness. The total current of all LEDs together corresponds approximately to the mean output current for operation with one LED.

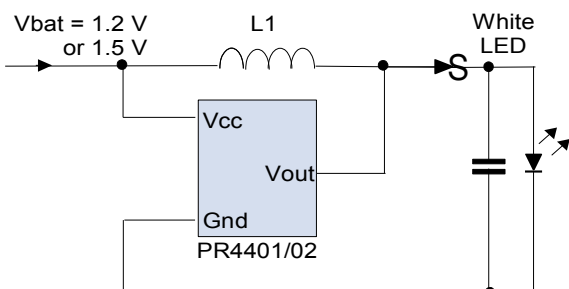
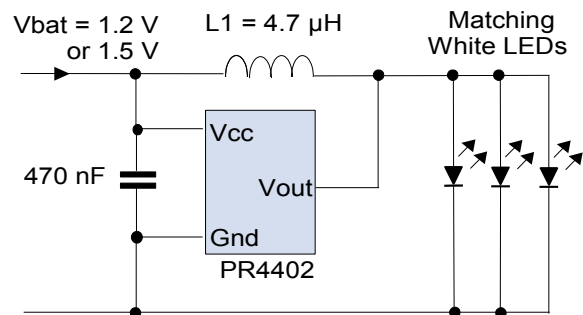

OPERATION OF LEDs WITH SMOOTHED CURRENT (RECTIFIER)

With a diode (preferably a Schottky diode) and a smoothing capacitor the voltage at the LED can be buffered if necessary. The capacitance must be small enough so that the voltage at the capacitor will exceed a voltage of 2.5 V in the first cycle, otherwise the circuit may not start up. In most cases, values between 100 nF and 1 μ F are appropriate. Due to different load characteristics, output current and efficiency are typically higher than without capacitor, especially in the high-current range.

LED Driver PR4401 / PR4402

Application Notes

RECOMMENDED CONFIGURATION FOR HIGHER LEDs CURRENTS

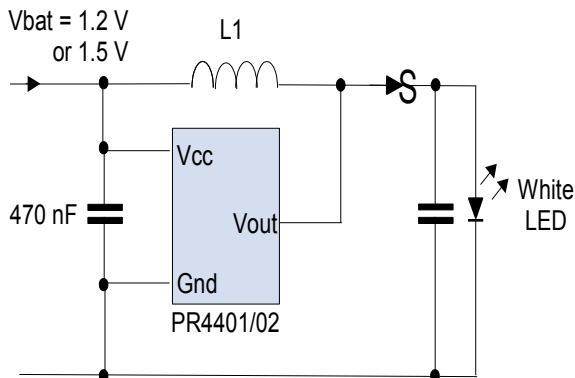

While for lower LED currents it is possible to operate PR4401 with the minimum number of components, it is recommended to provide both rectifier circuit at the output and buffer capacitor at the input at high LED currents, to achieve the best performance.

Whether the extra components are necessary or not depends largely on the performance of the components used, most importantly the peak current of the LED, the internal resistance of the battery and the resistance of the battery cables. If by adding the extra components the mean LED current increases significantly, it is usually advisable to add them permanently to achieve a high efficiency.

As a rule of thumb, with a 22 μH inductor the extra components will usually not increase the current significantly, while for inductors below 10 μH they will usually improve the performance noticeably.

Buffer capacitor and rectifier circuit are independent measures. For powerful LEDs, or two or more LEDs in parallel at the output, the rectifier may not be necessary, but the buffer capacitor will still prevent high voltage drops along the supply wire.

For the buffer capacitor, values between 220 nF and 1 μF are common.

CONNECTING TWO LEDs IN SERIES

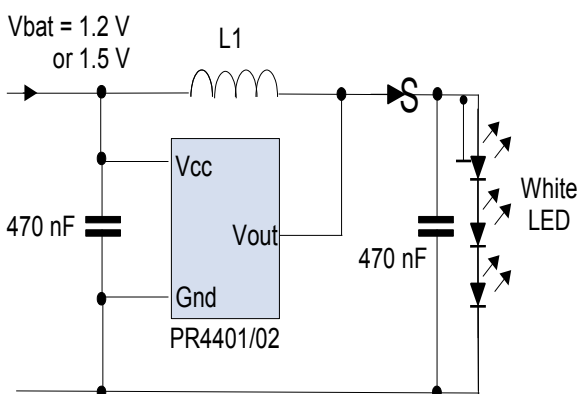

It is possible to operate PR4401 and PR4402 with two LEDs in series at the output. However, while the peak output current is nearly independent of the output load, the mean output current with two LEDs in series is reduced to half the current with one LED. In addition, at high output voltages the efficiency drops significantly, depending on operating

conditions, and current pulses become shorter and sharper. Therefore it is recommended to operate LEDs in this mode only in conjunction with the rectifier circuit as shown below.

USING RED, GREEN OR YELLOW LEDs

Although PR4401/PR4402 is optimized for operation with white or blue LEDs, it will usually also work with red, green or yellow LEDs, with the following restrictions:

- The LED must build up a sufficient forward voltage to trigger PR4401/PR4402. Due to the internal resistance of the LED, this condition is usually met. However, no guarantee can be assumed for proper operation under all conditions, and you need to qualify the system yourself.
- Due to the different forward voltage level and internal resistance of coloured LEDs, the timing is different, and mean currents are mostly lower than for white LEDs. Also other parameters may deviate from this data sheet.

LED Driver PR4401 / PR4402

Installation Notes

SAMPLE BOARD LAYOUT

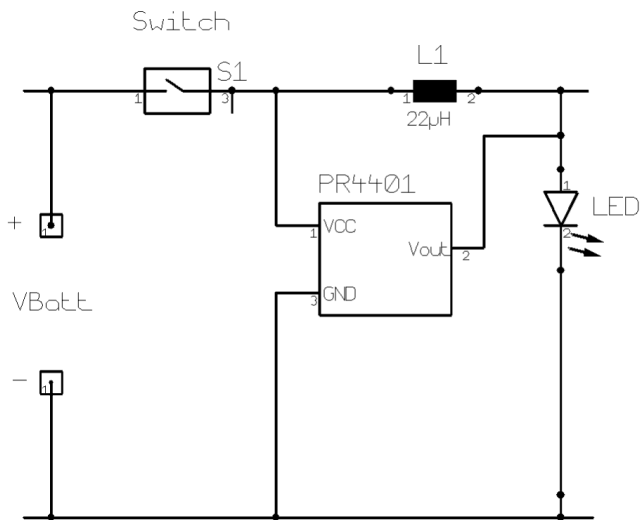

FLASHLIGHT BOARD WITH AAA BATTERY HOLDER

Size: 77.5 mm x 14 mm

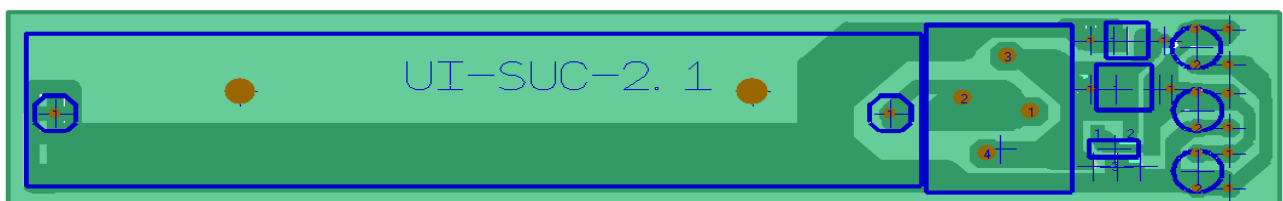
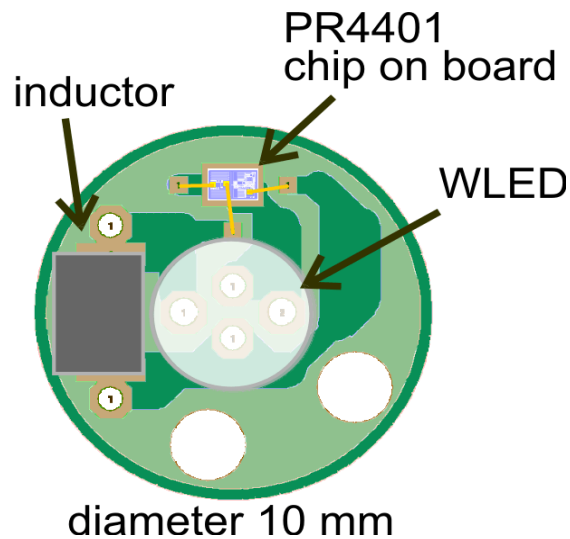

LED Driver PR4401 / PR4402

Available Packages

TYPICAL DIMENSIONS

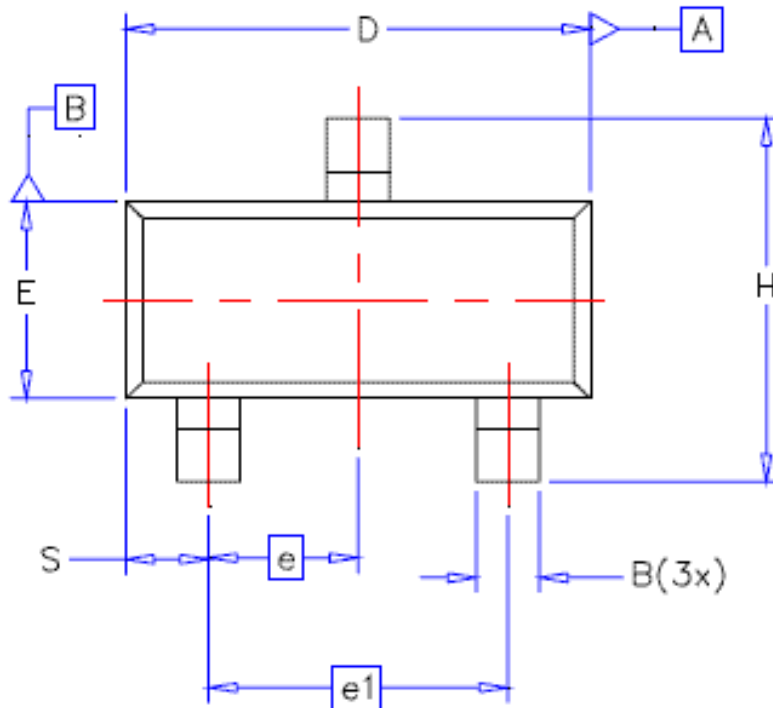

B = 0,40 mm
D = 2,92 mm
E = 1,30 mm
H = 2,37 mm
e1 = 1,92 mm

PR4401/PR4402 SOT23 package in tape and reel

Packing unit: 3000 ICs per reel
(reel diameter 7" / 178mm)

Delivery in die form on request.

All parts delivered comply with RoHS. Finish is pure tin.



Pb-free



pure tin

LED Driver PR4401 / PR4402

LED Driver PR4401 / PR4402

Disclaimer

Information provided by PREMA is believed to be accurate and correct. However, no responsibility is assumed by PREMA for its use, nor for any infringements of patents or other rights of third parties which may result from its use. PREMA reserves the right at any time without notice to change circuitry and specifications.

Life Support Policy

PREMA Semiconductors products are not authorized for use as critical components in life support devices or systems without the express written approval of PREMA Semiconductor. As used herein:

1. Life support devices or systems are devices or systems which, (a) are intended for surgical implant into the body, or (b) support or sustain life, and whose failure to perform when properly used in accordance with instructions for use provided in the labeling, can be reasonably expected to result in a significant injury to the user.
2. A critical component is any component of a life support device or system whose failure to perform can be reasonably expected to cause the failure of the life support device or system, or to affect its safety or effectiveness.

PREMA Semiconductor GmbH

Robert-Bosch-Str. 6

55129 Mainz Germany

Phone: +49-6131-5062-0

Fax: +49-6131-5062-220

Email: prema@prema.com Web site: www.prema.com