

**NPN SILICON HIGH VOLTAGE TRANSISTORS**

**BF257, BF 258, BF259**

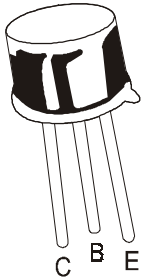

**TO-39  
Metal Can Package**

**INTENDED FOR VIDEO OUTPUT STAGES IN BLACK AND WHITE AND IN COLOUR TELEVISION RECEIVERS.**

**ABSOLUTE MAXIMUM RATINGS (Ta=25°C unless specified otherwise)**

DESCRIPTION	SYMBOL	BF257	BF258	BF259	UNITS
Collector Emitter Voltage	$V_{CEO}$	160	250	300	V
Collector Base Voltage	$V_{CBO}$	160	250	300	V
Emitter Base Voltage	$V_{EBO}$	<-----5----->			V
Collector Current Continuous	$I_C$	<-----100----->			mA
<b>Peak</b>	$I_{CM}$	<-----300----->			mA
Total Power Dissipation @ Ta=25°C	$P_D$	<-----1.0----->			W
Derate Above 25°C		<-----6.67----->			mW/°C
Total Power Dissipation@ Tc=25°C	$P_D$	<-----7----->			W
Derate Above 25°C		<-----46.67----->			mW/°C
Operating And Storage Junction Temperature Range	$T_j, T_{stg}$	<----- -65 to +175----->			°C
<b>THERMAL RESISTANCE</b>					
Junction to Ambient	$R_{th(j-a)}$	<-----150----->			°C/W
Junction to Case	$R_{th(j-c)}$	<-----21.43----->			°C/W

**ELECTRICAL CHARACTERISTICS (Ta=25° C unless specified otherwise)**

DESCRIPTION	SYMBOL	TEST CONDITION	BF257	BF258	BF259	UNITS
Collector Emitter Breakdown Voltage	$BV_{CEO}$	$I_C=10mA, I_B=0$	>160	>250	>300	V
Collector Base Breakdown Voltage	$BV_{CBO}$	$I_C=100\mu A, I_E=0$	>160	>250	>300	V
Emitter Base Breakdown Voltage	$BV_{EBO}$	$I_E=100\mu A, I_C=0$	>5	>5	5	V
Collector Cut off Current	$I_{CBO}$	$V_{CB}=100V, I_E=0$	<0.05			$\mu A$
		$V_{CB}=200V, I_E=0$		<0.05		$\mu A$
		$V_{CB}=250V, I_E=0$			<0.05	$\mu A$
DC Current Gain	$h_{FE}$	$I_C=30mA, V_{CE}=10V$	ALL	>25		
Collector Emitter Saturation Voltage	$V_{CE(Sat)}$	$I_C=30mA, I_B=6mA$		<1		V

**DYNAMIC CHARACTERISTICS**

Transition Frequency	$f_T$	$I_C=15mA, V_{CE}=10V$ $f=100MHz$		75		MHz
<b>TYP</b>						
Collector Base Capacitance	$C_{cb}$	$I_E=0, V_{CB}=30V, f=1MHz$		2.5		pF
<b>TYP</b>						

\*Pulse Test: Pulse Width  $\leq 300\mu s$ , Duty Cycle  $\leq 2\%$

**TO-39**  
**Metal Can Package**

**TO-39 Metal Can Package**

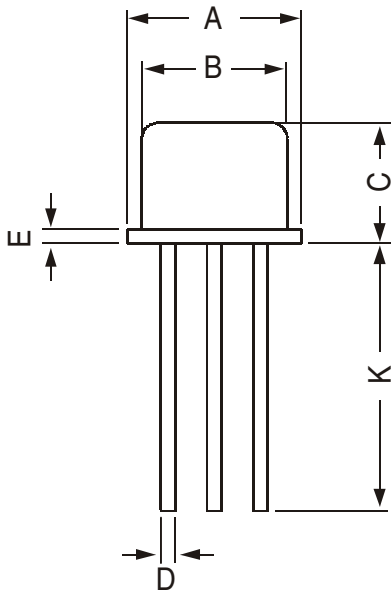

All dimensions are in mm

DIM	MIN	MAX
A	8.50	9.39
B	7.74	8.50
C	6.09	6.60
D	0.40	0.53
E	—	0.88
F	2.41	2.66
G	4.82	5.33
H	0.71	0.86
J	0.73	1.02
K	12.70	—
L	42 DEG	48 DEG

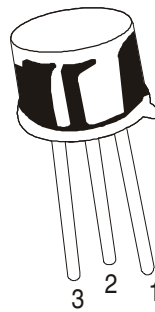
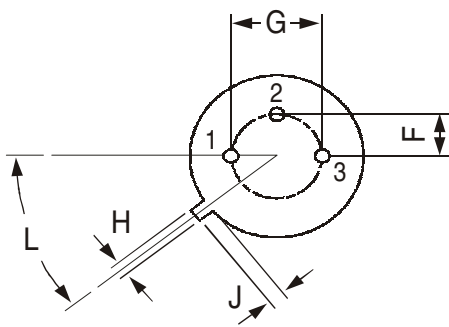

**PIN CONFIGURATION**

- 1. EMITTER
- 2. BASE
- 3. COLLECTOR

**Packing Detail**

PACKAGE	STANDARD PACK		INNER CARTON BOX		OUTER CARTON BOX		
	Details	Net Weight/Qty	Size	Qty	Size	Qty	Gr Wt
TO-39	500 pcs/polybag	540 gm/500 pcs	3" x 7.5" x 7.5"	20K	17" x 15" x 13.5"	32K	40 kgs

### **Disclaimer**

The product information and the selection guides facilitate selection of the CDIL's Discrete Semiconductor Device(s) best suited for application in your product(s) as per your requirement. It is recommended that you completely review our Data Sheet(s) so as to confirm that the Device(s) meet functionality parameters for your application. The information furnished in the Data Sheet and on the CDIL Web Site/CD is believed to be accurate and reliable. CDIL however, does not assume responsibility for inaccuracies or incomplete information. Furthermore, CDIL does not assume liability whatsoever, arising out of the application or use of any CDIL product; neither does it convey any license under its patent rights nor rights of others. These products are not designed for use in life saving/support appliances or systems. CDIL customers selling these products (either as individual Discrete Semiconductor Devices or incorporated in their end products), in any life saving/support appliances or systems or applications do so at their own risk and CDIL will not be responsible for any damages resulting from such sale(s).

CDIL strives for continuous improvement and reserves the right to change the specifications of its products without prior notice.