

## PNP SILICON PLANAR EPITAXIAL TRANSISTORS

**BC177, A, B, C**  
**BC178, A, B, C**  
**BC179, A, B, C**  
**TO-18**

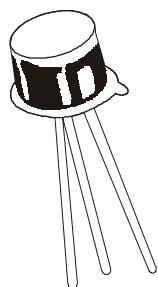

### ABSOLUTE MAXIMUM RATINGS

DESCRIPTION	SYMBOL	BC177	BC178	BC179	UNIT
Collector -Emitter Voltage	VCEO	45	25	20	V
Collector -Emitter Voltage	VCES	50	30	25	V
Collector -Base Voltage	VCBO	50	30	25	V
Emitter -Base Voltage	VEBO	5.0	5.0	5.0	V
Collector Current Continuous	IC		0.2		A
Power Dissipation@ Ta=25 degC	PD		0.6		W
Derate Above 25 deg C			2.28		mW/deg C
Power Dissipation@ Tc=25 degC	PD		1.0		W
Derate Above 25 deg C			6.67		mW/deg C
Operating And Storage Junction Temperature Range	Tj, Tstg		-65 to +200		deg C
<b>THERMAL RESISTANCE</b>					
Junction to Case	Rth(j-c)		175		deg C/W

### ELECTRICAL CHARACTERISTICS (Ta=25 deg C Unless Otherwise Specified)

DESCRIPTION	SYMBOL	TEST CONDITION	MIN	TYP	MAX	UNIT
Collector-Cut off Current	ICES	VCE=20V, IE=0 Tamb=125 deg C	-		100	nA
Collector -Base Voltage	VCBO	IC=10uA, IE=0	<b>BC177</b>	50	-	V
			<b>BC178</b>	30	-	V
			<b>BC179</b>	25	-	V
Collector -Emitter Voltage	VCEO	IC=2mA, IB=0	<b>BC177</b>	45	-	V
			<b>BC178</b>	25	-	V
			<b>BC179</b>	20	-	V
Emitter-Base Voltage	VEBO	IE=10uA, IC=0	5.0	-	V	
DC Current	hFE	IC=2mA, VCE=5V	<b>BC177</b>	120	460	
			<b>BC178</b>	120	800	
			<b>BC179</b>	180	800	
			<b>A Group</b>	120	220	
			<b>B Group</b>	180	460	
Collector Emitter Saturation Voltage	VCE(Sat)	IC=10mA, IB=0.5mA	-		0.20	V
		IC=100mA, IB=5mA	-		0.60	V
Base Emitter Saturation Voltage	VBE(Sat)	IC=10mA, IB=0.5mA	-		0.80	V
		IC=100mA, IB=5mA	-	0.90	-	V
Base Emitter on Voltage	VBE(on)	IC=2mA, VCE=5V	0.60		0.75	V

<b>ELECTRICAL CHARACTERISTICS (Ta=25 deg C Unless Otherwise Specified)</b>				<b>BC177XX</b>		
<b>DESCRIPTION</b>	<b>SYMBOL</b>	<b>TEST CONDITION</b>	<b>MIN</b>	<b>MAX</b>	<b>UNIT</b>	
<b>Collector Knee Voltage</b>	VCE (K)	IC=10mA, IB=The Value for Which IC=11mA, @ VCE=1V	-	0.60	V	
<b>Transition Frequency</b>	ft	VCE=5V, IC=10mA, f=50MHz	200	-	MHZ	
<b>Noise Figure</b>	NF	VCE=5V, IC=0.2mA Rg=2kohms, F=30Hz to 15 KHz	<b>BC179</b> -	4.0	dB	
		F=1kHz, F=200Hz	<b>BC179</b> -	4.0	dB	
			<b>BC177/178</b> -	10	dB	
<b>Output Capacitance</b>	Cobo	VCB=10V, f=1MHz	-	4.0	pF	
<b>Small Signal Current Gain</b>	hfe	ALL f=1kHz IC=2mA, VCE=5V	<b>BC177</b> 125 <b>BC178</b> 125 <b>BC179</b> 240 <b>A Group</b> 125 <b>B Group</b> 240 <b>C Group</b> 450	500 900 900 260 500 900		
<b>Input Impedance</b>	hie	IC=2mA, VCE=5V	<b>A Group</b> 1.6 <b>B Group</b> 3.2 <b>C Group</b> 6.0	4.5 8.5 15	Kohms Kohms Kohms	
<b>Output Admittance</b>	hoe	IC=2mA, VCE=5V	<b>A Group</b> - <b>B Group</b> - <b>C Group</b> -	30 60 110	umhos umhos umhos	

## TO-18 Metal Can Package

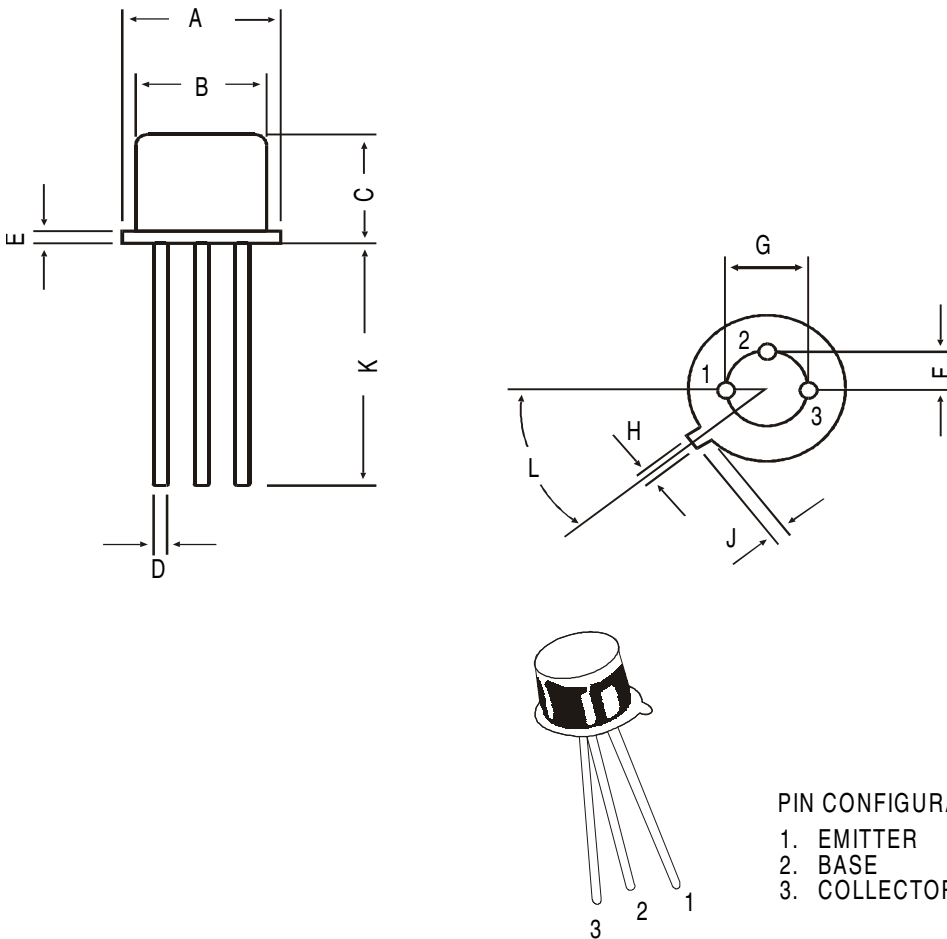

DIM	MIN	MAX
A	5.24	5.84
B	4.52	4.97
C	4.31	5.33
D	0.40	0.53
E	—	0.76
F	—	1.27
G	—	2.97
H	0.91	1.17
J	0.71	1.21
K	12.70	—
L	45 DEG	

All dimensions in mm.

### PIN CONFIGURATION

1. EMITTER
2. BASE
3. COLLECTOR

## Packing Detail

PACKAGE	STANDARD PACK		INNER CARTON BOX		OUTER CARTON BOX		
	Details	Net Weight/Qty	Size	Qty	Size	Qty	Gr Wt
TO-18	1K/polybag	350 gm/1K pcs	3" x 7.5" x 7.5"	5.0K	17" x 15" x 13.5"	80.0K	34 kgs

## Disclaimer

The product information and the selection guides facilitate selection of the CDIL's Discrete Semiconductor Device(s) best suited for application in your product(s) as per your requirement. It is recommended that you completely review our Data Sheet(s) so as to confirm that the Device(s) meet functionality parameters for your application. The information furnished on the CDIL Web Site/CD is believed to be accurate and reliable. CDIL however, does not assume responsibility for inaccuracies or incomplete information. Furthermore, CDIL does not assume liability whatsoever, arising out of the application or use of any CDIL product; neither does it convey any license under its patent rights nor rights of others. These products are not designed for use in life saving/support appliances or systems. CDIL customers selling these products (either as individual Discrete Semiconductor Devices or incorporated in their end products), in any life saving/support appliances or systems or applications do so at their own risk and CDIL will not be responsible for any damages resulting from such sale(s).

CDIL strives for continuous improvement and reserves the right to change the specifications of its products without prior notice.



CDIL is a registered Trademark of

**Continental Device India Limited**

C-120 Naraina Industrial Area, New Delhi 110 028, India.

Telephone + 91-11-579 6150 Fax + 91-11-579 9569, 579 5290

e-mail sales@cdil.com www.cdil.com