

Bearbeitungsmaß/ machining dimension X-1	Rastposition/ locking position	
24	1	Durch unterschiedlich hohe Einrastung des Riegels im Sockel, sind, zur Anpassung an die Gehäusehöhe, die nebenstehenden Bearbeitungsmaße zu berücksichtigen. Standardvormontage in Rastposition 2/ <i>Due to the different height levels of locking positions for lever and socket, please note the machining dimensions to adapt the TSH to the enclosure dimension, standard position = 2</i>
39	2	
54	3	
69	4	

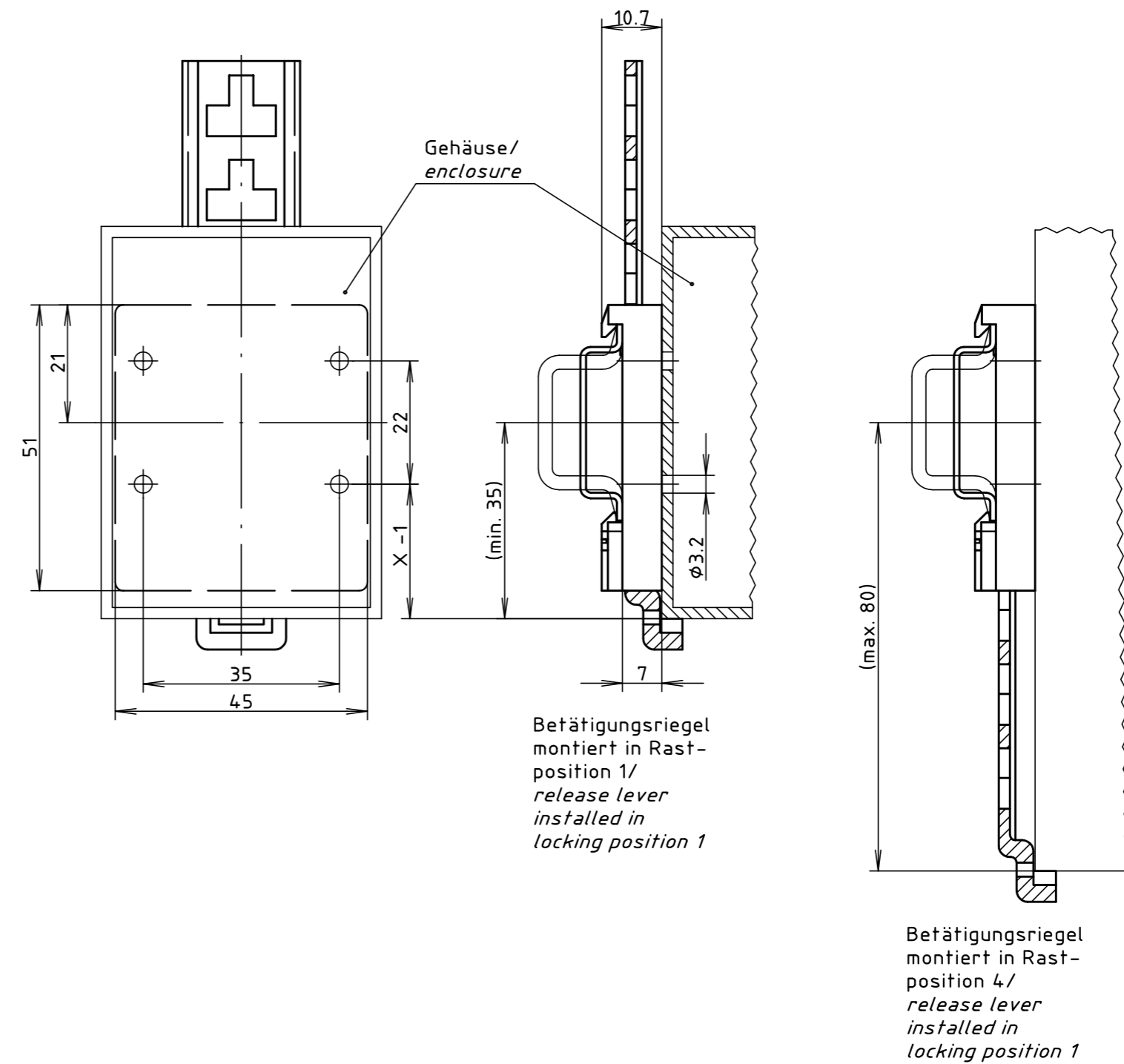

Belastbarkeit bei ruhender Last/  
*Carrying capacity (dead weight)*

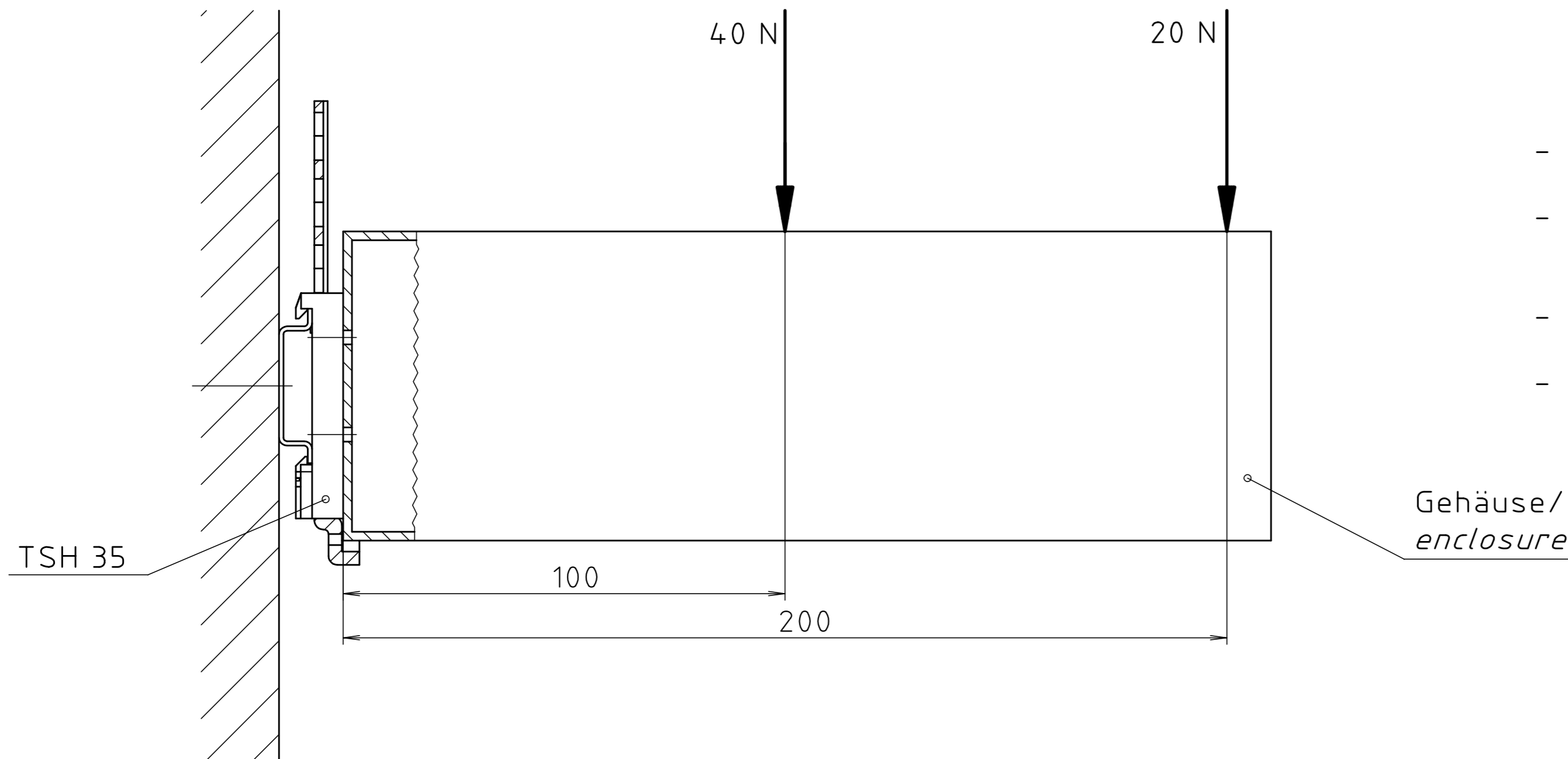

- Vorraussetzung:
- Ordnungsgemäße Montage der Tragschiene
  - Einwandfreie Montage des TSH 35 an das Gehäuse
- Conditions:
- *correct assembly of the DIN rail*
  - *correct assembly of TSH 35 to the enclosure*

Maßstab/ Scale:	1:1	
Zeichnungs-Nr. / Drawing-No.:	2K 0410.028.02	
Artikel / Article:	TSH 35	
Katalogzeichnung Catalogue drawing		
A.Nr. / Alt-No.:	3793	
Datum/ Date:	21.08.06	
DISK:	2 801 153	
Datum/Date:	11.01.94 FW	