



**ATTENTION**  
OBSERVE PRECAUTIONS  
FOR HANDLING  
ELECTROSTATIC  
DISCHARGE  
SENSITIVE  
DEVICES

**HL-PC-3216U70GC**

**GREEN**



**Features**

- 3.2mmx1.6mm SMT LED, 0.68mm THICKNESS.
- LOW POWER CONSUMPTION.
- WIDE VIEWING ANGLE.
- IDEAL FOR BACKLIGHT AND INDICATOR.
- VARIOUS COLORS AND LENS TYPES AVAILABLE.
- PACKAGE: 3000PCS / REEL.

**Description**

The Green source color devices are made with Gallium Arsenide Phosphide on Gallium Phosphide Green Light Emitting Diode.

**Package Dimensions**

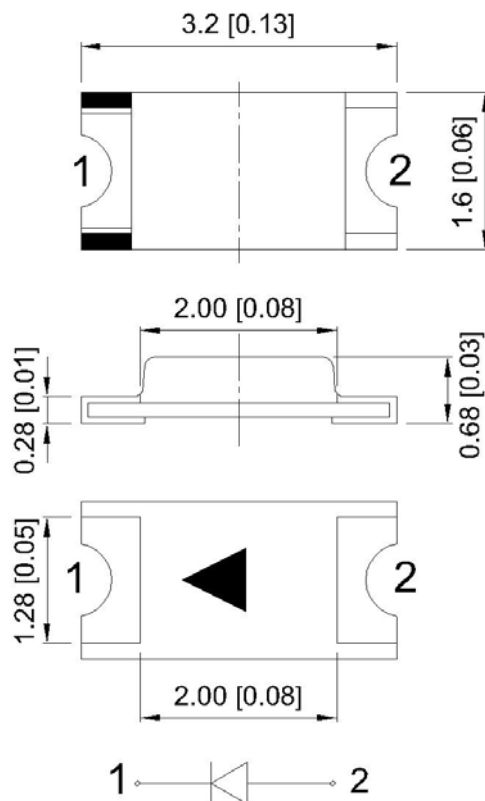

Notes:

1. All dimension units are millimeters.
2. All dimension tolerance is  $\pm 0.2\text{mm}$  unless otherwise noted.
3. An epoxy meniscus may extend about 1.5mm down the leads.

**Selection Guide**

Part No.	Dice	Lens Type	Iv (mcd) @ 20mA		Viewing Angle
			Min.	Typ.	θ1/2
HL-PC-3216U70GC	GREEN (InGaN)	WATER CLEAR	600	780	120°

Note:

1. θ1/2 is the angle from optical centerline where the luminous intensity is 1/2 the optical centerline value.

**Electrical / Optical Characteristics at TA=25°C**

Symbol	Parameter	Device	Min.	TYP.	Units	Test Conditions
λD	Dominant Wavelength	Green	515	520	nm	IF=20mA
C	Capacitance	Green		45	pF	VF=0V;f=1MHz
VF	Forward Voltage	Green	3.0	3.2	V	IF=20mA
IR	Reverse Current	Green	—	5	uA	VR= 5V

**Absolute Maximum Ratings at TA=25°C**

Parameter	Green	Units
Power dissipation	95	mW
DC Forward Current	25	mA
Peak Forward Current [1]	150	mA
Reverse Voltage	5	V
Operating/Storage Temperature	-40°C To +85°C	

Note:

1. 1/10 Duty Cycle, 0.1ms Pulse Width.

**GREEN HL-PC-3216U70GC**
**Reliability Test Items And Conditions**

The reliability of products shall be satisfied with items listed below.  
 Confidence level :90% LTPD :10%

No.	Items	Test Condition	Test Hours/Cycles	Sample Size	Ac/Rc
1	Reflow	Temp:260°C±5°C Min.5 sec.	6 Min.	22Pcs.	0/1
2	Temperature Cycle	H:+100°C 15 min. ∞ 5 min L:-40°C 15 min.	300 Cycles	22Pcs.	0/1
3	Thermal Shock	H:+100°C 5 min. ∞ 10 sec. L:-10°C 5 min.	300 Cycles	22Pcs.	0/1
4	High Temperature Storage	Temp.:100°C	1000Hrs.	22Pcs.	0/1
5	Low Temperature Storage	Temp.: -40°C	1000Hrs.	22Pcs.	0/1
6	DC Operating Life	I <sub>f</sub> =20mA	1000Hrs.	22Pcs.	0/1
7	High Temperature/High Humidity	85°C/85%RH	1000Hrs.	22Pcs.	0/1

\*The technical information shown in the data sheets are limited to the typical characteristics and circuit examples of the referenced products. It does not constitute the warranting of industrial property nor the granting of any license.

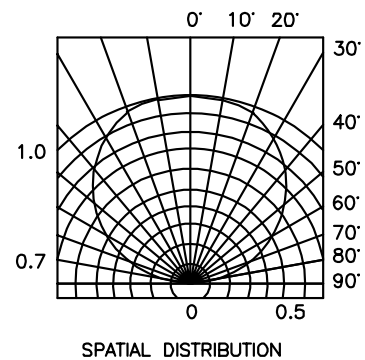
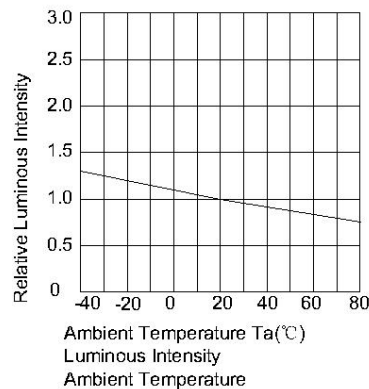
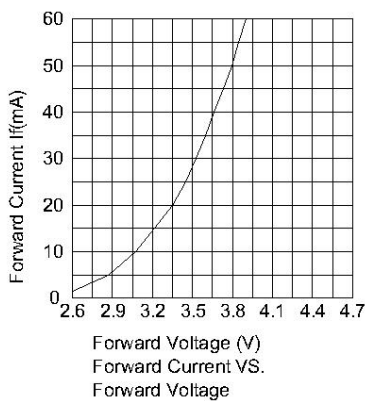
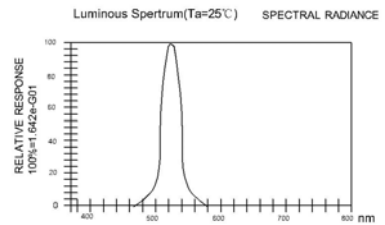
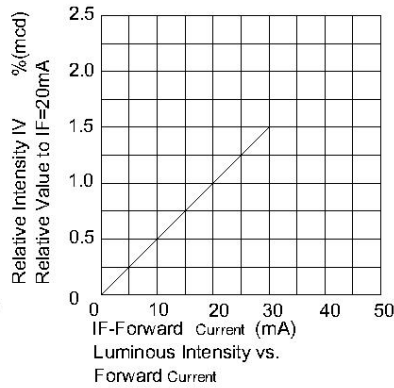
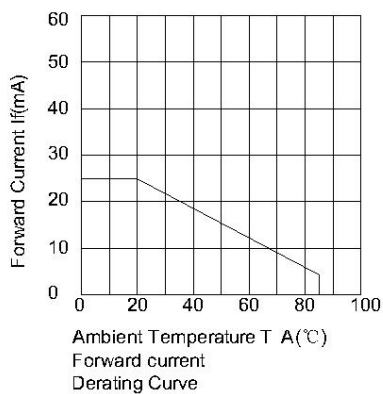

**HL-PC-3216U70GC**
**SMT Reflow Soldering Instructions**

Number of reflow process shall be less than 2 times and cooling process to normal temperature is required between first and second soldering process.

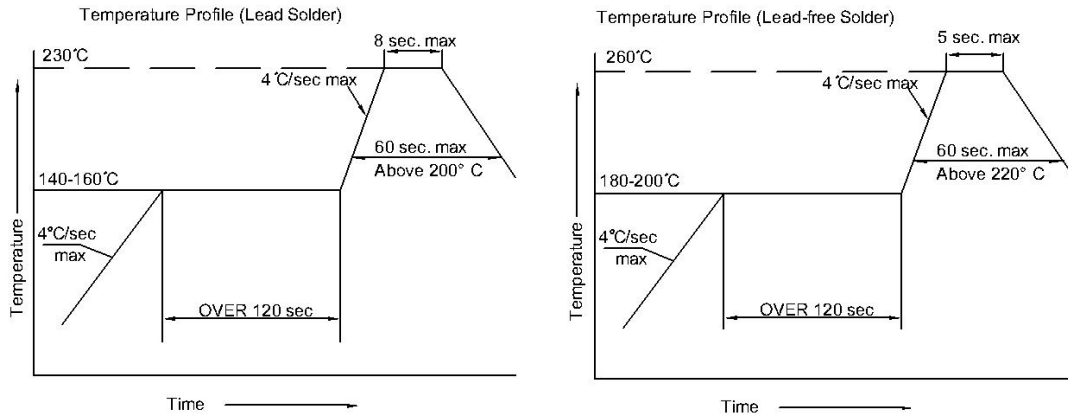
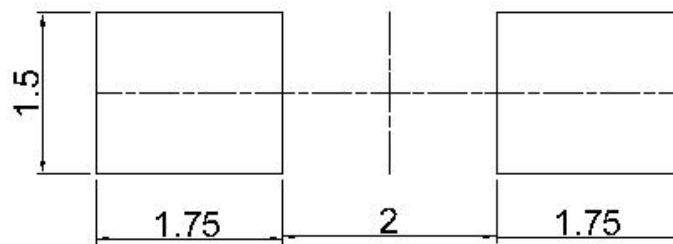
**Recommended Soldering Pattern  
(Units : mm)**

**Tape Specifications  
(Units : mm)**
