



Features:

- 13 Functions
- 10 Time Ranges
- Front knobs for Time Range, Time Scale & Mode Setting
- Slim, Space Saving Design
- DIN Rail Mount

Size: DIN 17.5mm

Certifications:

Technical Specifications

Input Specifications

Accuracy	Setting: $\pm 5\%$ of F.S. Repeat: $\pm 0.5\%$ (F.S. = Full Scale)
Reset	Reset time < 100 msec

Output Specifications

Output Contact	SPDT (1 C/O)
Contact Rating	NO/5A, NC/3A@250V AC

Functional Specifications

Modes	On delay (A) Interval (B) Cyclic equal OFF first (C) Cyclic equal ON first (Ci) Pulse output, 500ms fixed (D) Delay on break (E) Delay on make / Delay on break (F) Interval after break (H) Single shot (I) Retriggerable Single shot (J) Latching relay (K) Delay with Totalise (Ai) Interval with totalise (Bi)
Time Ranges	0.1 - 1 sec, 0.3 - 3 sec, 1 - 10 sec, 3 - 30 sec 0.1 - 1 min, 0.3 - 3 min, 1 - 10 min, 3 - 30 min 0.1 - 1 hr, 0.3 - 3 hr

Supply Voltage

Supply Voltage	20-240V AC 12-240V DC AC : (50 / 60 Hz)
Power Consumption	3.2 VA

Environmental Specifications

Temperature	Operating: 0 to 50°C (32 to 122°F) Storage: -20 to 75°C (-4 to 167°F)
Humidity (non-condensing)	95% RH
Weight	64 gms
Protection Level	IP40 for Casing IP20 for terminals

Dimensions

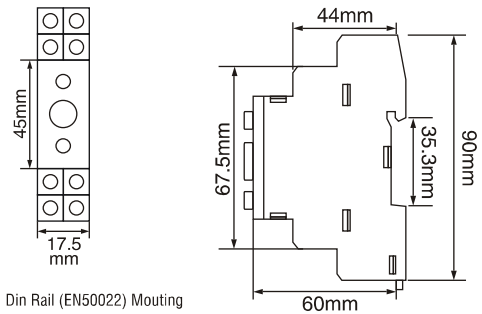

Symmetrical 35mm Din Rail (EN50022) Mounting

Terminal Connections

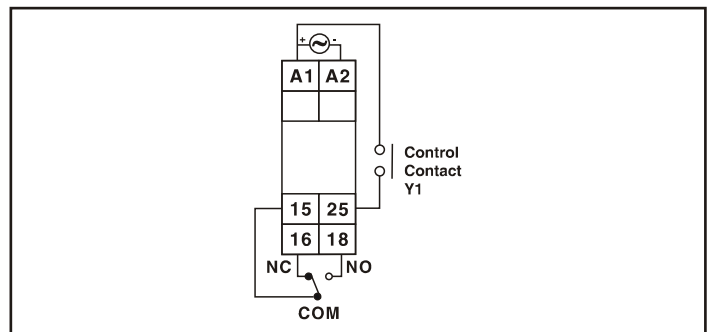

Cable Size (AWG): 16 ; Tightening Torque (Lb-inch): 5.3...7.08 ibf.in

Cable Size (mm²): 1.5 ; Tightening Torque (N-m): 0.6...0.8 N. M

Ordering Information

Part No.	Supply Voltage	Certification	
600XU	20-240V AC 12-240V DC	■	
600XU-A-1-CU	20-240V AC 12-240V DC	■	■

Timing Diagram

