

24MM 标准回转型电位器

24mm SIZE STANDARD ROTARY POTENTIOMETERS

Model

Dimensions

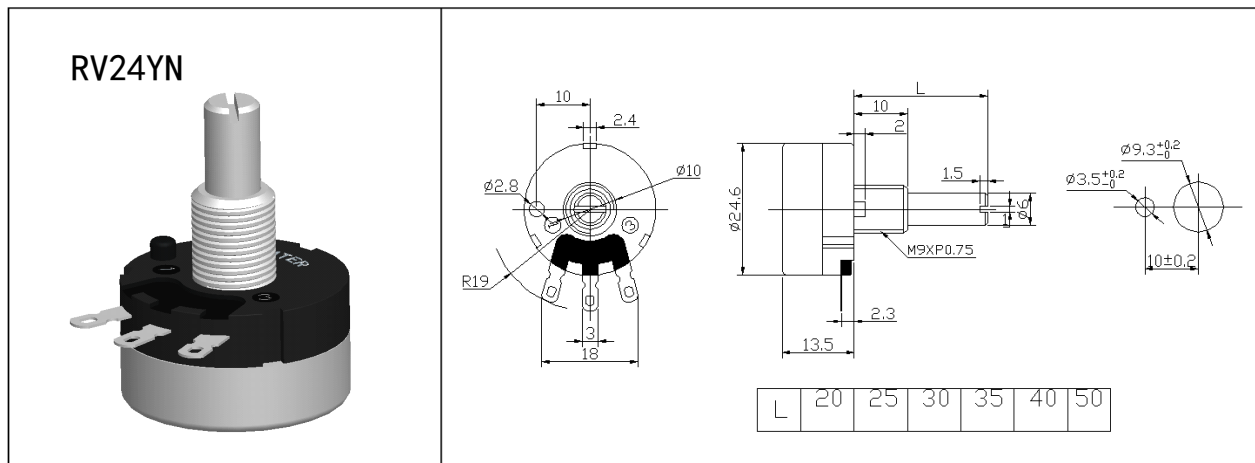

Specifications

Electrical

Standard Resistance Range.....B = 50Ω to 2MΩ
A.C = 1kΩ to 2MΩ
resistance Tolerance.....±10% standard
End Resistance.....3Ω max.
Resistance Taper.....B = linear; A = CW audio (logarithm);
C = CCW audio (logarithm)
Peak Noise (C.R.V.).....3% or 3Ω, whichever is greater
Power Rating.....B = 0.25 watt; A, C = 0.125 watt
at +40°C. 0 watt at +85°C
Maximum Input Voltage.....B = 315VDC; A, C = 200VDC
or power rating, whichever is smaller
Insulation Resistance.....100MΩ minimum at 1.000VDC
Dielectric Strength.....1,000VAC, 1 minute
Adjustment Travel.....280°±10°

Mechanical

Mechanical Travel.....300°±5°
Shaft Torque
Single Unit.....51 to 306 gf.cm (0.707 to 4.242 oz•in)
Other Units.....51 to 510 gf.cm (0.707 to 7.070 oz•in)
Stop Strength9.18 kgf.cm (127.26 oz.in) max.
Mounting Nut Torque.....15 kgf.cm (207.94 oz.in) max.
Solderability.....235°C 5 seconds
MarkingModel type, taper, resistance code.
shaft type, terminal identification, date code

Environmental

Temperature Range.....-10°C to +85°C
temperature Characteristics.....+85°C, 30 minutes
without load
R ≤ 10kΩ → ΔT/R ≤ ±6%
10kΩ < R < 1MΩ → ΔT/R ≤ ±10%
R ≥ 1MΩ → ΔT/R ≤ ±15%
Load Life.....+40°C. 1,000 hours with rated load
AT/R ≤ ±10%
Moisture and Load Life.....+40°C. 90-95%RH.
500 hours with rated load
R < 100kΩ → ΔT/R ≤ -10% - +15%
R ≥ 100kΩ → ΔT/R ≤ -10% - +20%
Thermal Shock.....-10°C ~ +85°C.
5 cycles without load
ΔT/R ≤ ±10%
Vibration.....10-55Hz, 1.5mm amplitude.
3 directions. 2 hours each
ΔT/R ≤ ±2.5%
Soldering Heat Resistance.....350°C. 3 seconds
ΔT/R ≤ ±2%
Rotational Life.....15,000 cycles (500 cycles for shaft lock
models only) without load
ΔT/R ≤ ±7%
Standard Rotary Switches
Switch Rating.....110VAC, 1A or 3A. SPDT or SPST
Contact Resistance.....0.05Ω max.
Operating Torque.....1,530 gf.cm (21.21 oz•in) max.
Operating Life.....10,000 cycles without load
R. Total Resistance Value; ΔT/R. Total Resistance Change

30MM 标准回转型电位器

30mm SIZE STANDARD ROTARY POTENTIOMETERS

Model

Dimensions

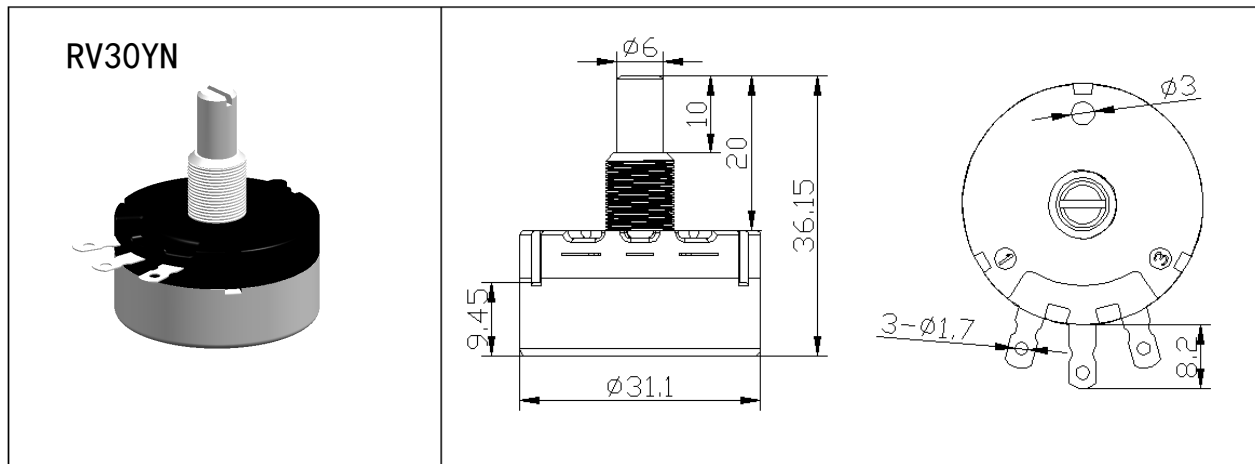

Features.

- 30mm diameter, single-turn industrial panel controls ■ Carbon film element ■ Linear or audio tapers
- Single, tandem and triple units, single shaft; dual unit, dual shaft ■ SPST or SPOT switch with 1A or 3A rating
- Shaft lock models ■ Metal shaft and bushing ■ Panel mount only ■ Right angle ear-lug terminals
- 6mm diameter shafts in slot, flat or round end styles ■ Standard 15mm or 20mm shaft length

Specifications

Electrical

Standard Resistance Range.....B = 100Ω to 2MΩ
A, C = 1kΩ to 2MΩ
Resistance Tolerance.....±10% standard
End Resistance.....3Ω max.
Resistance Taper.....B = linear; A = CW audio (logarithm);
C = CCW audio (logarithm)
Peak Noise (C.R.V.).....3% or 3Ω whichever is greater
Power Rating.....Ratings below at +40°C, 0 watt at +85°C

Taper	R ≤ 10K Ω	10K Ω < R ≤ 50K Ω	50K Ω < R ≤ 300K Ω	R > 300K Ω
B	1.0W	0.8W	0.6W	0.4W
A.C	0.8W	0.6W	0.3W	0.2W

Maximum Input Voltage.....B = 500VDC; A.C = 350VDC
or power rating, whichever is smaller
Insulation Resistance.....100MΩ minimum at 1,000VDC
Dielectric Strength.....1,000VAC, 1 minute
Adjustment Travel.....280° ±10°

Mechanical

Mechanical Travel.....300° ±5°
Shaft Torque
Single Unit.....51 to 306 gf.cm (0.707 to 4.242 oz.in)
Other Units.....51 to 510 gf.cm (0.707 to 7.070 oz.in)
Stop Strength.....10.2 kgf.cm (141.4 oz.in) max.
Mounting Nut Torque.....15 kgf.cm (207.94 oz.in) max.
Solderability.....235°C, 5 seconds
Marking.....Model type, taper, resistance code.
shaft type, terminal identification, date code

Environmental

Temperature Range.....-10°C to +85°C
Temperature Characteristics.....+85°C, 30 minutes
without load
R ≤ 10kΩ - ΔT/R ≤ ±6%
10kΩ < R < 1MΩ - ΔT/R ≤ ±10%
R ≥ 1MΩ - ΔT/R ≤ ±15%
Load Life.....+40°C, 1,000 hours with rated load
ΔT/R ≤ ±10%
Moisture and Load Life.....+40°C, 90-95%RH.
500 hours with rated load
R < 100kΩ - ΔT/R ≤ -10% - +15%
R ≥ 100kΩ - ΔT/R ≤ -10% ~ +20%
Thermal Shock.....-10°C ~ +85°C,
5 cycles without load
ΔT/R ≤ ±10%
Vibration.....10-55Hz, 1.5mm amplitude,
3 directions, 2 hours each
ΔT/R ≤ ±2.5%
Soldering Heat Resistance.....350°C, 3.5 seconds
ΔT/R ≤ ±2%
Rotational Life.....15,000 cycles (500 cycles for shaft lock
models only) without load
ΔT/R ≤ ±7%
Standard Rotary Switches
Switch Rating.....110VAC, 1A or 3A, SPOT or SPST
Contact Resistance.....0.05Ω max.
Operating Torque.....1.530 gf.cm (21.21 oz.in) max.
Operating Life.....10,000 cycles with rated load
R. Total Resistance Value; ΔT/R. Total Resistance Change