

Magnetic Transducer Buzzer Series

KLS3-MWC-12*9.5 $\phi 12 \times 9.5$ mm With Circuit Magnetic Transducer Buzzer Series

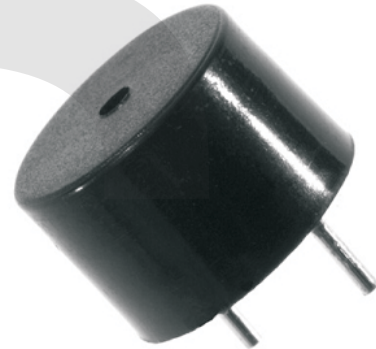

Dimensions (Unit:mm)

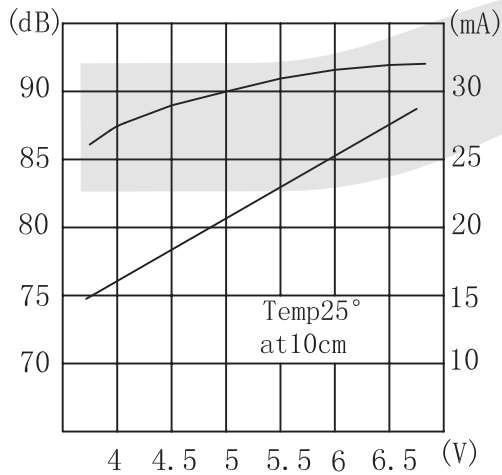
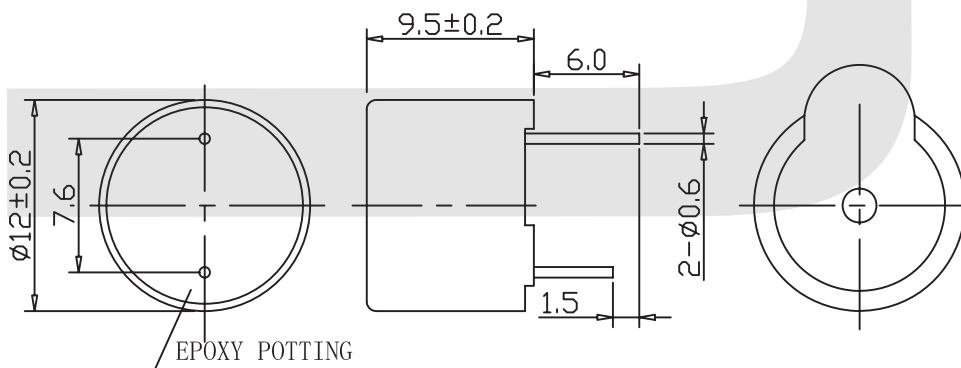

Order Code	Rated Voltage	Operating Voltage	Max. Rated Current	Min. S.P.L. (@10cm)	Resonant Frequency	Operating Temp	Weight
KLS3-MWC-12*9.5-A	1.5V _{DC}	1.2~3V _{DC}	30mA	75dB	2.3 ±0.4KHz		
KLS3-MWC-12*9.5-B	3V _{DC}	2~5V _{DC}	30mA	80dB	2.3 ±0.3KHz		
KLS3-MWC-12*9.5-C	5V _{DC}	4~7V _{DC}	30mA	85dB	2.3 ±0.3KHz	-20 ~ +70 °C	2g
KLS3-MWC-12*9.5-D	9V _{DC}	7~11V _{DC}	30mA	85dB	2.3 ±0.3KHz		
KLS3-MWC-12*9.5-E	12V _{DC}	8~16V _{DC}	30mA	85dB	2.3 ±0.3KHz		

ORDER INFORMATION

Product NO.: **KLS3- MWC - 12*9.5 - A**

