

# ED SERIES SAFETY LIMIT SWITCH - HIGHLY

HIGHLY

The ED series safety limit switches conform to EN 50047 and have been developed to provide a range of options including plastic cases in various sizes, a choice of snap acting, slow break/make with 2 contact configurations and a choice of actuator heads. The ED series offers the option of rotating the head in 90° increments before installation to allow ease of mounting. Highly limit switches can be used in other applications other than guard doors, for example on moving machine beds, crane arms, lifts, elevators, etc. Operation of these limit switches is achieved by the sliding action of the guard or other moving object deflecting the plunger or lever. For safety applications it is important that upon actuation, the guard or other moving objects should not pass completely over the switch and allow the plunger or lever to return to its original position.

## Features:

- Conforms to EN (TUV) standards corresponding to the CE marking
- Positive opening operation of NC (Normally Closed) contacts conforming to IEC /EN 60947-5-1
- Double insulation makes ground terminal unnecessary (Bears marking)
- Wide standard operating temperature range: -25°C to 80°C
- Full range of actuator heads and levers suitable for safety applications
- Sealing up to IP 67
- Wide switch variations, (Snap action and slow action basic switches)
- International conduit sizes

## SPECIFICATIONS:

<b>Standards</b>	EN60947-5-1, UL508, EN50047, EN1088
<b>Approvals</b>	cULus, TUV and CE marked for all applicable directives
<b>Positive Opening Operation</b>	NC Contact
<b>Utilization Category</b>	AC15 A600
<b>Min Current</b>	5V, 5mA, DC
<b>Thermal Current (Ith)</b>	10A
<b>Rated Insulation Voltage</b>	600V AC
<b>Rated Impulse withstand Volt</b>	2500V AC
<b>Insulation Resistance</b>	100MΩ min. (DC 500V)
<b>Contact Resistance</b>	25mΩ max. (Initial)
<b>Max Switching Speed</b>	250mm/s
<b>Max Switching Frequency</b>	6000 operation per hour
<b>Enclosure Material</b>	UL approved glass-filled polybutylene terephthalate
<b>Roller Material</b>	Various polymers
<b>Enclosure Protection</b>	IP 67
<b>Operating Temperature</b>	Min -25°C (-18°F) Max 80°C (+176°F)
<b>Pollution Degree</b>	3
<b>Protection Against Electric Shock</b>	Class II (Double Insulation)
<b>Mech. Life Expectancy</b>	1 x 10 <sup>7</sup> Cycle min
<b>Electrically Life Expectancy</b>	150,000 Cycle min
<b>Vibration</b>	IEC 68-2-6, 10-55Hz±1 Hz, Excursion: 0.35mm, 1 octave/min
<b>Conduit Entry</b>	Various (see Product Selection table)
<b>Fixing</b>	2 x M4

## Structure Description

### Metal Lever Setting

Grooves which engage the lever every 18° are cut in the operation indicator disk to prevent the lever from slipping against the rotary shaft.

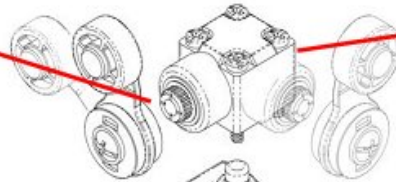

### Hand

With roller lever models, the direction of the switch head can be varied to any of the four directions by loosening the roller lever switch screws at the four corners of the head.

### Cover

The cover, with a hinge on its lower part, can be opened by removing the screw of the cover, which ensures ease of maintenance and wiring.

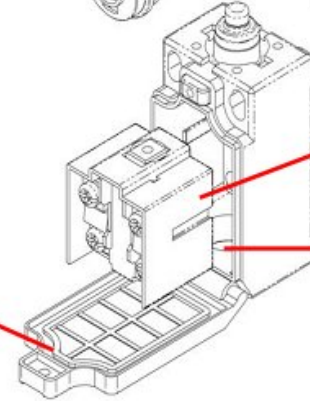

### Contact Block

Wide switch variations.  
Snap-action: 1NC/1NO  
Slow-action: 1NC/1NO, 2NC

### Conduit

Wide switch variations.  
PG13.5 PG11  
M16 M20  
1/2-14NPT

## Product Selection

ED-□-□-□  
1 2 3

### 1. THREAD DIMENSION OF LEAD EXIT

- 1: PG13.5 (S)
- 2: 1/2NPT (C)
- 4: PG11 (O)
- 5: M16 (C)
- 6: M20 (O)
- 7: Connector (C)

### 2. CONTACT TYPES

- 1: 1NC/1NO SLOW ACTION (BBM) (S)
- 2: 2NC SLOW ACTION (O)
- 3: 1NC/1NO SNAP ACTION (C)

### 3. HEAD AND ACTUATOR

- 20: Roller arm type
- 21: Adjustable roller arm type (standard roller)
- 22: Adjustable roller arm type (Long arm type)
- 24: Thermoplastic end flexible rod type
- 241: Cat whisker type
- 242: Wobble stick type
- 25: Rod lever type
- 27: Adjustable roller arm type (big roller)
- 31: Push plunger type
- 32: Roller plunger type
- 62: Roller lever type
- 63: One-Way roller arm lever type

\*(s):standard (o):option (c): customization

M12 Connector pin arrangement

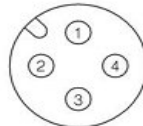

## Contact Block Form

TYPE	CONTACT FORM	CONNECTOR PIN ARRANGEMENT	OPERATION DIAGRAMS	
			Closed	Open
ED-□-1-□□	1NC/1NO(Slow action) (See Note 1)			
ED-□-2-□□	2NC (Slow action) (See Note 2)			
ED-□-3-□□	1NC/1NO(Snap action) (See Note 1)			

Note: 1. Only NC contact 11-12 has an approved positive opening mechanism.

2. NC contacts 11-12 and 21-22 have an approved positive opening mechanism.

# Positive Opening Mechanism

## 1NC/1NO Contact (Snap action)

Conforms to EN60947-5-1 Positive Opening

If metal deposition between mating contacts occurs on the NC contact side, they can be pulled apart by the shearing force and tensile force generated when the safety cam or plunger engages the movable contact blade. When the safety cam or plunger is moved in the direction of the black arrow the Limit Switch releases.

1. When metal deposition occurs.
2. When contacts are being pulled apart.
3. When contacts are completely pulled apart.

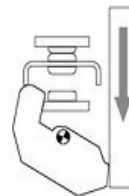
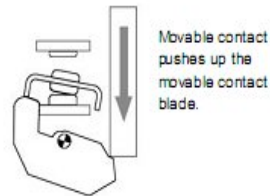
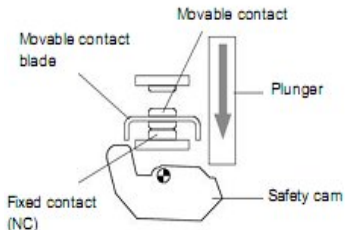

ED-241  
Cat Whisker Type

Slow Action 2NC  
ED-\_\_-2-241

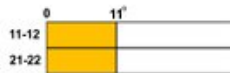

Snap Action 1NC/1NO  
ED-\_\_-3-241

