

## Tact Switch Series

### KLS7-TS4501 4.5x4.5mm Tact Switch Series

#### ELECTRICAL

1. Rating: 50mA 12VDC
2. Contact Resistance : 50mΩ max(initial)
3. Insulation Resistance: 100MΩ(minDC 250V)
4. Dielectric Strength : AC250V(50/60Hz for 1minute)
5. Electrically Life: 100000cycles
6. Environment temperature: -20°C~+70°C
7. Operating Force: 180/250(±30gf)
8. Seal temperature: 260°C~ 280°C

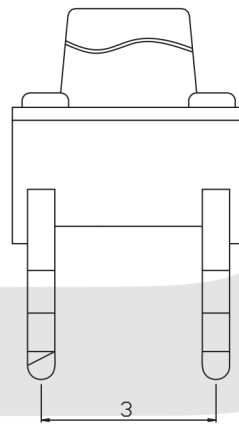
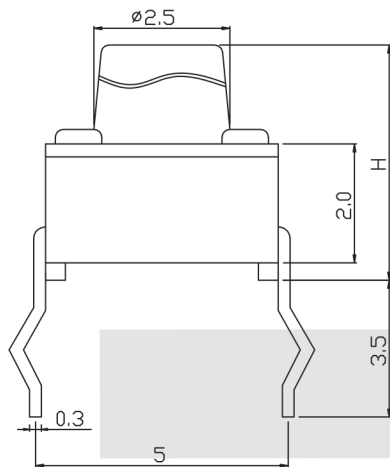

H
3.8
4.8
7.0
8.5

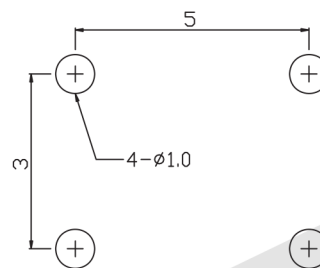
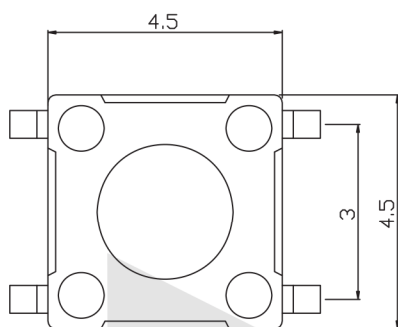

PCB LAYOUT

## ORDER INFORMATION

**KLS7-TS4501 - 4.3 - 180 - B**

Series No. \_\_\_\_\_  
Hight: 3.8mm/4.8mm/  
7.0mm/8.5mm

Packing: B=Bulk T=Tape  
Operating Force : 180~250gf