

*Maxair*TM

SPECIFICATIONS

FOR APPROVAL

Model: 12038S2XT

AC220V 50/60Hz 0.14/0.12A

Maxair™

SPECIFICATION

<u>Item</u>	<u>Specification/Condition</u>
Dimension	: 120x120x38 mm
Bearing System	: SLEEVE BEARING
Rated Voltage	: 220 VAC
Operating Voltage	: 200 VAC—240 VAC
Start-up Voltage	: 160 VAC NORMALLY
Rated Current	: 0.14/0.12 Amp NORMALLY
Rated Power	: 22/21 Watt NORMALLY
Rated Speed	: 2700/3100 RPM±10%
Air Flow	: 95/115 CFM (2.68/3.25 m ³ /min)
Static Air Pressure	: 8.38/9.65 mmH ₂ O
Noise Level	: 42/47dBA
Motor Protection Type	: BY IMPEDANCE
Life Expectance	: 20000 Hours at Room Temperature
Operation Temperature	: -10°C to +70°C
Net Weight	: 530 Grams

Maxair™

MATERIAL

1. Impeller : Thermoplastic PBT of UL 94V-0
2. Bobbin : Thermoplastic PA66 of UL 94V-0
3. Lead Wire : UL 1430 AWG#22

DIMENSIONS: MM

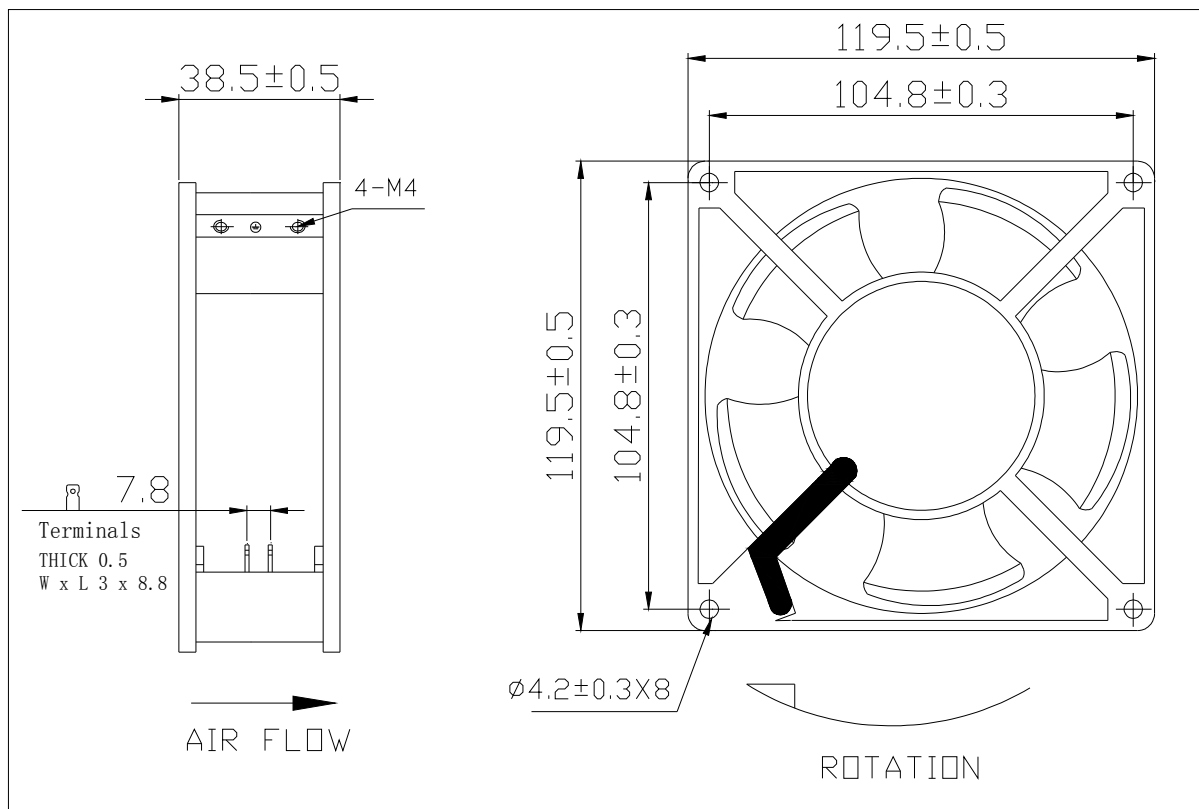

Maxair™

Performance Curve

