

PPAC series / PPAC-XXAS series

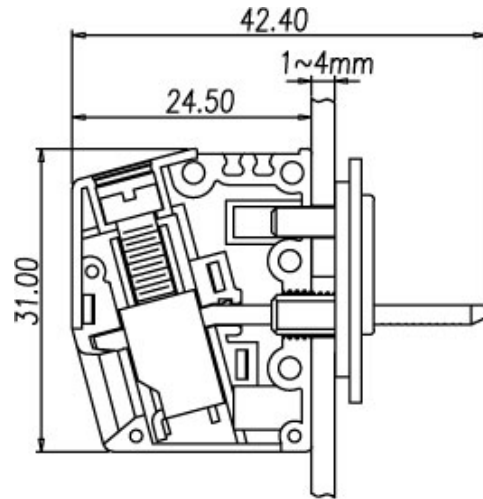

PPACN-10AS / PPACN-10ASG



Approval	<b>UL</b>	
Technical Data	UL	IEC
Rated voltage	300V	400V
Rated current	65A	76A
Conductor cross-section, solid (AWG / mm <sup>2</sup> )	24~6 / 0.5~16	
Conductor cross-section, flexible (AWG / mm <sup>2</sup> )	24~6 / 0.5~10	
Rated impulse withstand voltage	6KV	
Torque (N-m)	1.7	
Screw	M4	
Wire strip length	10mm	
Insulating material	PA	
Outer dimension TxHxW (mm)	10.1 x 31 x 24.5	
Inner dimension TxHxW (mm)	10.1 x 25 x 16.9	

	Accessories	Cat. No.
Marking label		TM22
Tool		



Dimension

